

O.A. Avdieieva, L.V. Vakhonina, O.S. Sadovoy, R.A. Stavinskiy, O.M. Tsyganov

Improving the main indicators of transformers with twisted one-piece magnetic cores by changing the technology of circular winding turns formation

Introduction. With the adoption of standards to reduce losses in transformers it is necessary to change the design of transformers that remain unchanged. Further energy saving is possible with the use of non-traditional technical solutions for the improvement of transformers. **Problem.** In order to reduce idle losses, the curved magnetic circuits of power transformers are carried out in the form of low-volume circuits. Windings are injected into assembled magnetic conductors by shuttle machines. The shuttle of windings provides technological gaps in winding windows, which results in an increase in size, metal capacity and losses. **Goal.** Rationale for transformer performance improvement by excluding process gaps in winding windows. **Methodology.** The definition of the change in transformer indicators is performed using optimization functions of the dimensionless indicators of the technological level. The adequacy of the functions is confirmed by the calculation of the mass of the electromagnetic system and the losses of the transformer. The figures of the compact analogue are calculated from the named serial analogue. **Results.** The result is a reduction in mass and a loss in the compactness of the transformer. **Originality.** The improvement of the indicators and the simplification of the winding technology are provided by a change in the design of insulating frames of winding coils. Winding on the rods is ensured by rotating the outer part of the composite insulating frame. **Practical significance.** Replacement the design of the windings of transformer with power of 40 kVA of 1000 V voltage class with a spatially twisted, small-dimensional magnetic conductor on a compact analogue leads to a reduction in mass and overall dimensions by 15 % and (17-18) %. Efficiency increases by 0.3 %. References 14, tables 2, figures 4.

Key words: twisted transformer, one-piece magnetic core, insulating frame, coil, winding.

Виконано аналіз конструктивно-технологічних особливостей електромагнітних систем трансформаторів з витими нероз'ємними магнітопроводами і круговими утворюючими контурами стрижнів та обмоткових витків. Запропоновано конструкцію обмоткової котушки з зовнішньою рухомою та внутрішньою нерухомою частинами опорно-ізоляційного каркасу та заміну вмотки витків на технологію намотки. Показано, що використання замість човникової вмотаної конструкції виконання обмотки з зовнішньою частиною ізоляційного каркаса, що обертається, призводить до поліпшення масогабаритних і енергетичного показників трансформатора. Бібл. 14, табл. 2, рис. 4.

Ключові слова: витий трансформатор, нероз'ємний магнітопровід, ізоляційний каркас, обмотка, намотка.

Problem definition. The total power of transmission system transformers exceeds the generation power by 6-7 times, with the main resource costs and the main losses of five to six times the transformation of electricity accounted for transformers I-III dimensions of mass production [1]. Since the beginning of the 21st century, new standards have been adopted in developed countries, regulating a significant reduction in losses of non-operating movement of low and medium power transformers and reducing the load loss of large transformers [1-5]. Block diagrams and designs of electromagnetic systems (EMS) of transformers in production are indispensable for a century, and the reduction of losses is through the use of innovations in materials science and reducing electromagnetic loads [6]. Further growth of energy saving requirements requires the use of new innovative technical solutions to improve transformers [1-6].

Analysis of recent research and publications. In the last century, the production of magnetic cores of transformers based on plate lamination was supplemented by technologies of winding tape (roll) of electrical steel (ES). The twisted magnetic cores of low-power transformers are made dissected. The presence of joints leads to an increase in losses of up to 30 %. Therefore, twisted magnetic conductors used in the production of single-phase and three-phase transformers up to

2000 kVA are made continuous (integral) with circular forming contours of rods and winding coils (Fig. 1, a, b). Winding with circular turns is wound on shuttle machines, which provides a technological increase in the design gap between adjacent winding coils and between the windings and yokes of transformers with rod and armor magnetic cores. Metal capacity, dimensions and losses are increasing, which reduces the efficiency of ES winding technology in the production of single-phase and three-phase transformers.

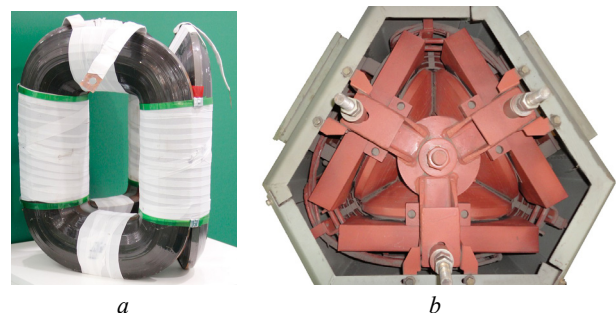

Fig. 1. Twisted three-section magnetic core (a) and top view of the transformer TSM-40-74.OM5 with removed cover (b)

The main modern means of energy efficiency of transformers is the use of tape amorphous ES with minimal losses, but with less operating magnetic flux density and higher cost [1, 7, 8].

Symmetrical spatial twisted axial magnetic conductors (Fig. 1,*a*) made of amorphous ES provide significant opportunities for improving three-phase transformers according to [5]. Thus three-phase transformers, in particular TSZM and TSZMV of sea execution (Fig. 1,*b*) with anisotropic magnetic conductors of a kind (fig. 1,*a*) are mastered in manufacture in 60th years of the 20th century and are manufactured now (Technical description and operating instructions. 140.240, Moscow, InformElectro, 1975, order 1265, 21 p., in Russian).

In addition to the use of tape anisotropic microcrystalline and amorphous ES and three-phase EMS with twisted three-section spatial magnetic cores [5-7] the main innovations are «cable» windings and the use of high-temperature superconductivity windings [1]. There are also opportunities to improve transformers by structural transformations of EMS elements [6]. Known examples of relatively simple structural transformation of twisted magnetic cores are the use of a combination of ES brands in the inner and outer zones and middle layers of ES and the replacement of the outer section of a three-phase three-rod planar magnetic core with two side sections twice as wide [9-11]. However, according to [1, 5] there is a contradiction between the market requirements for cheaper transformer products and the global trend of energy saving based on innovative designs and technologies. In addition, there is the possibility of improving transformers through the use of «residual reserves» of traditional designs and innovative methods of manufacturing EMS elements [6].

Recently, twisted magnetic cores of transformers of limited power are being replaced by analogues with conditionally oblique joints and the technology of forming covering layers by separating and bending sections of the tape of varying length. Special equipment is used to form layers of steel with offset joints («Unicore» – magnetic cores) [1, 12]. However, the use of this technology in the production of EMS with circular forming contours (Fig. 2,*a,b*) of twisted sections (Fig. 3,*a*) with the configuration of the steel scan (Fig. 3,*b*) causes additional difficulties. Also, brittle amorphous steel (glass metal) does not allow small bending radii.

Based on the above, solution of the problem of reducing weight, material consumption and losses, as well as labor costs in the manufacture of transformers with twisted magnetic cores is relevant.

The goal of the paper is to increase the basic indicators of the transformer on the example of electromagnetic systems with wound «shuttle» and wound windings as well as justification of the feasibility of increasing the filling of the winding window by conductors based on changes in winding.

Research methods and results. Increasing the compactness of the EMS by eliminating technological gaps in the winding windows can be considered a reserve for improving transformers with twisted integral magnetic cores. Such an increase is possible by change the

insulation design and change with the simplification of the technology of manufacturing windings by removing the kinematic links of the winding shuttles

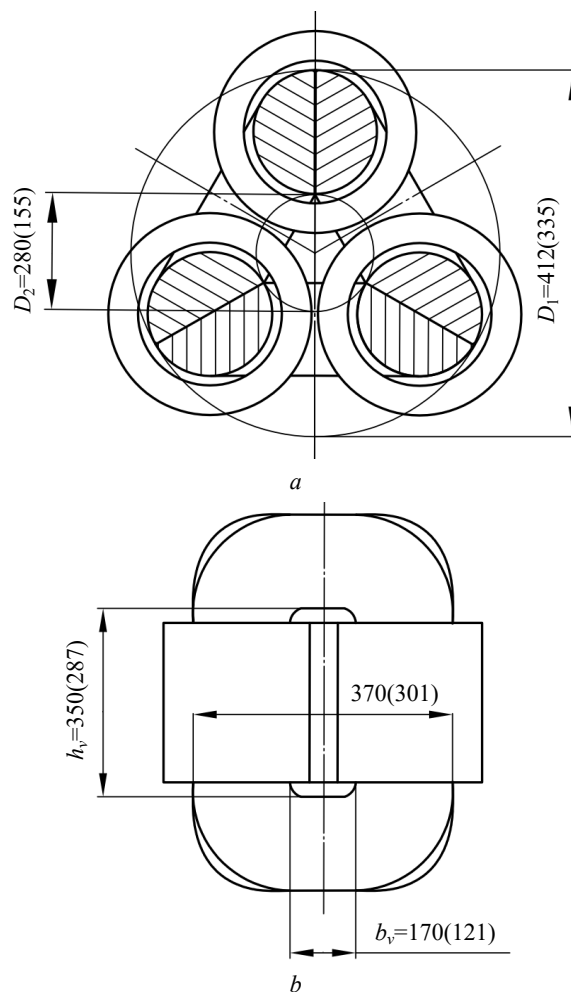

Fig. 2. Geometric parameters of the electromagnetic system of the transformer TSZM-40-74.OM5 with $K_w'' = 0.177$ and its analogue with $K_w'' = 0.3$ in cross section (*a*) and side view (*b*)

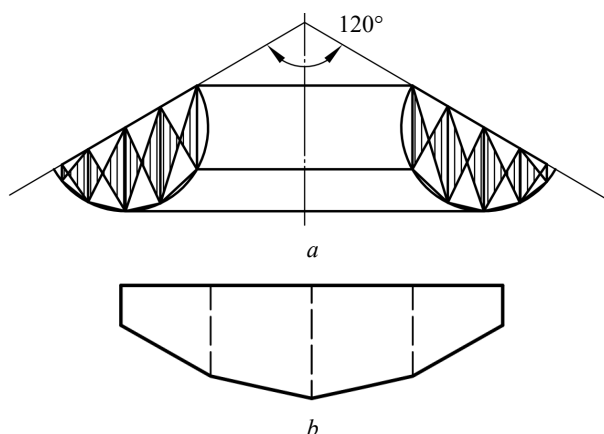

Fig. 3. Schemes of magnetic core section (*a*) and sectional electrical steel strip scan (*b*)

To eliminate technological winding gaps and butt gaps providing the possibility of respectively «shuttle run-in» of the insulating cylinder (layers of turns) and installation of winding coils on the detachable rod part of

the magnetic core, a design with two-layer support-insulating base windings is proposed (Fig. 4,a). The inner insulating cylinder of the winding frame, covering the rod, is stationary. The outer layer of the winding frame is a movable cylinder which is connected to the annular insulating elements located above the ends of the winding coils. The surfaces of the zones of the outer diameters of the rings form a kinematic connection with the transmitter of rotational motion from the drive of the winding device (Fig. 4,b).

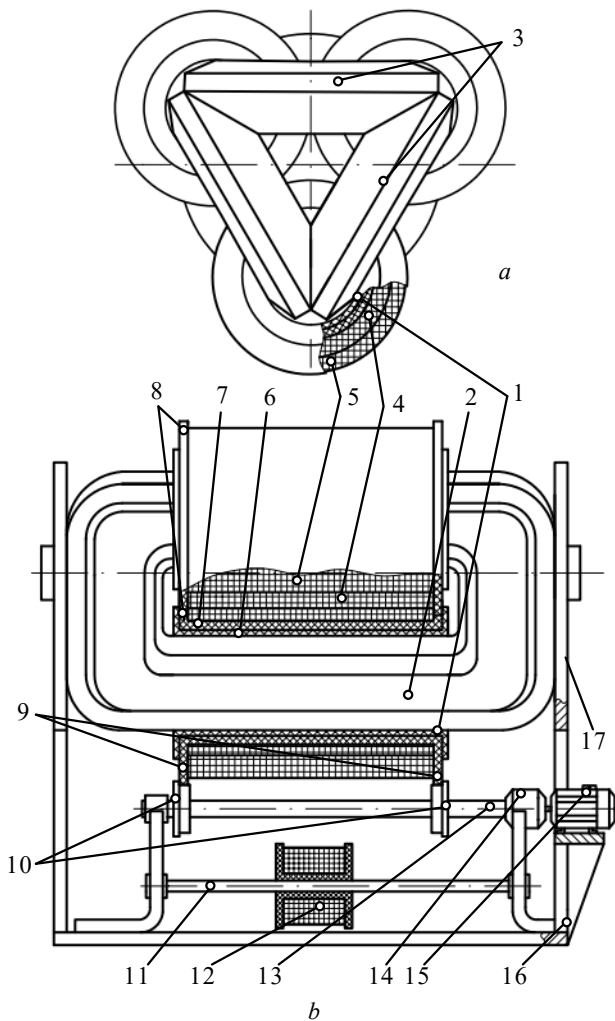

Fig. 4. Top view of the active part (a) and the schematic diagram of the winding equipment on the rotating components of the insulating frames (b): transformer with twisted one-piece magnetic core: 1 – frame; 2 – rod; 3 – magnetic core; 4, 5 – winding turns of low and high voltages; 6, 7 – fixed and movable insulation layers; 8 – annular insulating element; 9 – kinematic pair; 10 – torque transmitter; 11 – axis; 12 – winding turns coil workpiece; 13 – shaft; 14 – reducer; 15 – drive motor; 16 – base; 17 – support

The winding of the windings on the rods is provided by the rotation of the outer part of the prefabricated winding frame. After winding the phase coils, the outer cylinder is fixed. Concentric winding frames are formed by bonding, in particular gluing, of semi-annular workpieces.

Comparison of EMS variants (Fig. 2) is performed on the basis of the universal method of structural and structural-parametric synthesis of electromechanical devices [6]. The target functions of mass F_m and active power losses F_e with dimensionless optimization components $I_m^*(x_c, y_w)$ and $I_e^*(x_c, y_w, z_e)$ and relative controlled variables [6]:

$$F_m = (I_T)^{3/4} \gamma_{st} I_m^*(x_c, y_w, K_w^{(v)}); \quad (1)$$

$$F_e = (I_T)^{3/4} \gamma_{st} I_e^*(x_c, y_w, z_e, K_w^{(v)}), \quad (2)$$

where I_T is the indicator of output data and electromagnetic loads of the transformer [6]; x_c is the ratio of the diameters D_1 and D_2 of the calculated circles of the magnetic core (Fig. 2,a); y_w is the ratio of the height h_v and the width b_v of the winding window (Fig. 2,b); $K_w^{(v)}$ is the coefficient of filling of the winding window with copper (voltage class); z_e is the electromagnetic controlled variable; γ_{st} , P_{st} are the density and specific losses of ES, respectively.

Indicators of mass and losses of the mathematical model of the transformer with EMS (Fig. 1,b and Fig. 2) are determined by equations [13, 14]:

$$I_m^*(x_c, y_w, K_w^{(v)}) = 2,07 \left\{ \left[K_w^{(v)} K_R K_{st} f(x_c, y_w) \right]^{3/4} \times \left\{ K_w^{(v)} K_R \left[(y_w + 1)(1 - 0,0718x_c)(x_c - 1)^2 + 0,657(x_c - 1)^3 \right] + 3,482 K_w^{(v)} y_w (1 - 0,0718x_c)^2 (1 - 0,0718x_c) \gamma_{cu} / \gamma_{st} \right\} \right\} \quad (3)$$

$$I_e^*(x_c, y_w, z_e, K_w^{(v)}) = 2,07 K_{st} \left\{ \left[K_w^{(v)} K_R K_{st} f(x_c, y_w) \right]^{3/4} \times \left\{ K_w^{(v)} K_R \left[(y_w + 1)(1 - 0,0718x_c)(x_c - 1)^2 + 0,657(x_c - 1)^3 \right] + 3,482 z_e K_w^{(v)} y_w (1 - 0,0718x_c)^2 (1 - 0,0718x_c) \right\} \right\} \quad (4)$$

$$f(x_c, y_w) = y_w (1 - 0,0718x_c)^2 (x_c - 1)^2,$$

where K_{st} is the filling factor of the ES magnetic core; K_R is the filling factor of the circular forming contour by the cross section of the rod; K_{lst} is the coefficient of additional losses of non-working movement; γ_{cu} is the density of copper.

The calculation substantiation of expediency of change of a design of an insulating framework and a way of laying of a winding in a one-piece magnetic core is executed on an example of the three-phase transformer TSZM-40-74.OM5 (Fig. 1,b) and the estimated data of its compact analogue are given in Table 1.

Table 1
Main technical characteristics of the three-phase transformer «TT-40»

Variant	Rated power, kW	Voltage U_1/U_2 , V	Mass of the active part, kg	Efficiency
TSZM-40-74.OM5	40	380/230	182	0.973
Analogue	40	380/230	154.15	0.976

The calculation of the value of losses and efficiency of variants TT-40 (Table 1) is performed at the value of the relative electromagnetic controlled variable [14]

$$z_e = \frac{K_{l_{cu}} \gamma_{cu}^2 P_{cu}^2 J_w^2}{K_{l_{st}} \gamma_{st} P_{st}} = \frac{1,04 \cdot 8900 \cdot 2,4 \cdot 10^{-12} \cdot (2 \cdot 10^6)^2}{1,34 \cdot 76500 \cdot 1,1} = 7,88; \quad (5)$$

where $K_{l_{cu}}$, P_{cu} , J_w are, respectively, the coefficient of additional short-circuit losses, the indicator of specific losses and the current density of the copper windings of the TT-40 dry variant.

The coefficient $K_{l_{st}}$ is determined by the presence of third harmonics of the sectional magnetic fluxes of the magnetic core. Specific losses P_{st} correspond to the amplitude of the magnetic flux density 1.6 T and ES brand 3407.

The values of geometric and design parameters of the TT-40 variants are presented in Table 2. The calculated values (Table 1) of EMS mass and TSZM losses (Fig. 1,b) practically coincide with the passport data, which confirms the adequacy of the mathematical model [13, 14]. These values are obtained by (3), (4), data and real values of the size of the EMS (Fig. 2).

Table 2
Geometric and design parameters of «TT-40» variants

Variants	Values of controlled variables, p.u.			Efficiency
	x_c	y_w	z_e	
TSZM-40-74.OM5	412/208= =1.98	350/170= =2.06	7.88	0.177
Analogue	335/155= =2.16	287/301= =2.37	7.88	0.3

The calculated values of the indicators (Table 1) of the compact analogue TT-40 are determined at identical for the options (Fig. 2) values of I_T (1), (2). The extreme values x_c , y_w of (3), (4) meet the criterion for optimizing the minimum mass of the EMS.

Increasing the value $K_w^* = 0.177$ to a value corresponding to the voltage class up to 1000 V ($K_w^* = 0.3$), leads to a significant improvement in the technical characteristics of the TT-40.

Conclusions.

Replacement of the wrapped «shuttle» electromagnetic systems design with continuous tape (one-piece) sections of the magnetic core by compact design without technological intercoil gaps leads to improved indicators of transformers with twisted three-section magnetic cores.

The reduction in the mass and dimensions of the electromagnetic systems of voltage class 1000 V at power of 40 kVA is approximately 15 % and (17-18) %. The efficiency increases by about 0.3 %.

Conflict of interest. The authors declare no conflict of interest.

REFERENCES

1. Kostinskiy S.S. The review of the condition of branch of transformer manufacture and tendencies of development of the design of power transformers. *Izvestiya Vysshikh Uchebnykh Zavedenii. Problemy Energetiki*, 2018, vol. 20, no. 1-2, pp. 14-32. (Rus). doi: <https://doi.org/10.30724/1998-9903-2018-20-1-2-14-32>.
2. Targosz R., Topalis F.V. Energy efficiency of distribution transformers in Europe. *2007 9th International Conference on Electrical Power Quality and Utilisation*, 2007, pp. 1-5. doi: <https://doi.org/10.1109/EPQU.2007.4424121>.
3. De Almeida A., Santos B., Martins F. Energy-efficient distribution transformers in Europe: impact of Ecodesign regulation. *Energy Efficiency*, 2016, vol. 9, no. 2, pp. 401-424. doi: <https://doi.org/10.1007/s12053-015-9365-z>.
4. Charalampopoulos C., Psomopoulos C.S., Ioannidis G.Ch., Kaminaris S.D. Implementing the EcoDesign Directive in distribution transformers: First impacts review. *AIMS Energy*, 2017, vol. 5, no. 1, pp. 113-124. doi: <https://doi.org/10.3934/energy.2017.1.113>.
5. *Innovative breakthrough in the power transformer market*. (Rus). Available at: <http://www.elec.ru/articles/innovacionnye-proryv-na-rynke-silovyh-transformatorov> (Accessed 24 March 2021).
6. Stavinskii A.A., Avdeyeva Y.A., Pal'chikov O.O., Stavinskii R.A. The Generalized Method for Structural-Parametric Synthesis of the Electromagnet Systems of Electrical Machines and Induction Apparatuses. Part 1. Results from a Comparative Analysis of Different Versions of Three-Phase Transformer Electromagnet Systems. *Elektrichestvo*, 2017, vol. 4, pp. 39-49. (Rus). doi: <https://doi.org/10.24160/0013-5380-2017-4-39-49>.
7. Almen J., Breitholtz M. *Performance evaluation of amorphous hexa-core for distribution transformers*. Bachelor's Thesis in Electric Power Engineering. Chalmers University of Technology, Gothenburg, Sweden 2012. 50 p. Available at: <https://publications.lib.chalmers.se/records/fulltext/167013.pdf> (Accessed 20 March 2021).
8. Najafi A., Iskender I. Comparison of core loss and magnetic flux distribution in amorphous and silicon steel core transformers. *Electrical Engineering*, 2018, vol. 100, no. 2, pp. 1125-1131. doi: <https://doi.org/10.1007/s00202-017-0574-7>.
9. Kefalas T. Transformers Made of Composite Magnetic Cores: An Innovative Design Approach. *Recent Patents on Electrical Engineering*, 2009, vol. 2, no. 1, pp. 1-12. doi: <https://doi.org/10.2174/1874476110902010001>.
10. Kefalas T.D., Kladas A.G. Development of Distribution Transformers Assembled of Composite Wound Cores. *IEEE Transactions on Magnetics*, 2012, vol. 48, no. 2, pp. 775-778. doi: <https://doi.org/10.1109/TMAG.2011.2172976>.
11. Kefalas T.D., Magdaleno-Adame S. Techno-economic comparative evaluation of mixed and conventional magnetic wound cores for three-phase distribution transformers. *Electric Power Systems Research*, 2018, vol. 155, pp. 331-339. doi: <https://doi.org/10.1016/j.epsr.2017.11.003>.
12. Hernandez I., Olivares-Galvan J.C., Georgilakis P.S., Canedo J.M. A Novel Octagonal Wound Core for Distribution Transformers Validated by Electromagnetic Field Analysis and Comparison With Conventional Wound Core. *IEEE Transactions on Magnetics*, 2010, vol. 46, no. 5, pp. 1251-1258. doi: <https://doi.org/10.1109/TMAG.2010.2040623>.
13. Avdieieva E.A., Stavinskiy R.A. Mass and cost figures for spatial axial three-phase electromagnetic systems with circular and hexagonal forming contours of twisted magnetic core rods. *Electrical Engineering & Electromechanics*, 2014, no. 1, pp. 15-20. doi: <https://doi.org/10.20998/2074-272X.2014.1.02>.

14. Avdieieva E.A., Stavinskiy R.A. Watt loss in three-phase transformers with circular and hexagonal forming contours of twisted spatial magnetic core rods. *Electrical Engineering & Electromechanics*, 2014, no. 2, pp. 14-17. doi: <https://doi.org/10.20998/2074-272X.2014.2.02>.

Received 17.01.2022
Accepted 23.03.2022
Published 01.06.2022

O.A. Avdieieva¹, PhD,
L.V. Vakhonina², PhD, Associate Professor,
O.S. Sadovoy², PhD,
R.A. Stavinskiy¹, PhD, Associate Professor,
O.M. Tsyganov², PhD,

¹ Admiral Makarov National University of Shipbuilding,
9, Avenue Heroes of Ukraine, Mykolaiv, 54020, Ukraine,
e-mail: e.avdeeva@ukr.net

² Mykolayiv National Agrarian University,
9, Georgiya Gongadze Str., Mykolaiv, 54020, Ukraine,
e-mail: sadovuyos@mnau.edu.ua (Corresponding author)

How to cite this article:

Avdieieva O.A., Vakhonina L.V., Sadovoy O.S., Stavinskiy R.A., Tsyganov O.M. Improving the main indicators of transformers with twisted one-piece magnetic cores by changing the technology of circular winding turns formation. *Electrical Engineering & Electromechanics*, 2022, no. 3, pp. 3-7. doi: <https://doi.org/10.20998/2074-272X.2022.3.01>