

Towards Fuzzy Logic-based Erroneous AND-Gateways Detection and Quality Assessment of BPMN Models

Andrii Kopp^a, Mykhailo Godlevskiy^a and Dmytro Orlovskiy^a

^a National Technical University “Kharkiv Polytechnic Institute”, Kyrpychova str. 2, Kharkiv, 61002, Ukraine

Abstract

This paper proposes the idea of fuzzy logic-based erroneous Parallel Gateways detection and quality assessment of BPMN models, since incorrect parallel workflow executions may cause errors both in business process models and in real organizational activities.

Keywords

Business Process Model, Parallel (AND) Gateways, Fuzzy Logic, Quality Assessment

Introduction

Business process modeling is a key element of Business Process Management (BPM), as it allows structuring, analyzing, and improving enterprise operations, facilitating innovation in accordance with Industry 4.0 concepts [1]. Process visualization improves communication between participants and reduces errors through clear graphical interpretation [2]. At the same time, business process models serve as the basis for monitoring activities and effective decision-making. The quality of these models is critical, as it affects the maintainability, scalability, and success of BPM projects.

Among the popular notations for modeling business processes, the most common are BPMN, EPC, and IDEF, but BPMN (Business Process Model and Notation) has gained the most recognition for its ability to combine simplicity of visual representation with high expressiveness of process logic [3].

A study by [4] shows that BPMN has supplanted notations such as EPC due to its standardization, support by large software platforms, and ability to clearly represent control flows through elements (Fig. 1) such as Pools, Lanes, Events, Activities, and Gateways, which allows for a detailed description of process behavior in dynamics.

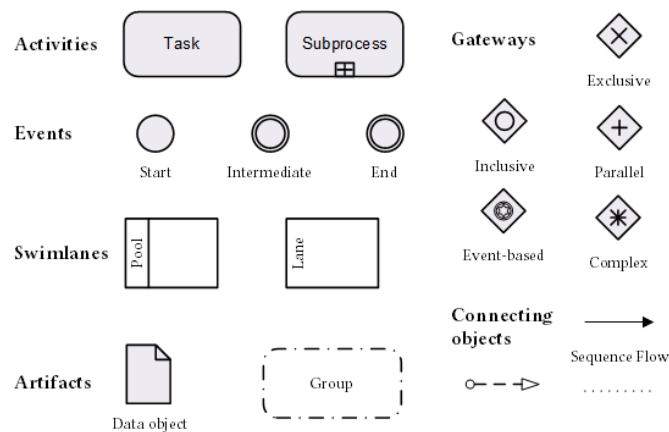

Figure 1: Various BPMN elements used for business process modeling

Detecting erroneous Parallel (AND) Gateways in BPMN models is critical, as these elements often lead to logical contradictions or unwanted parallel executions, which can cause process failures and significantly reduce the overall quality and reliability of the model.

Therefore, the study aims to improve the quality of business process models described using BPMN, by detecting erroneous AND-Gateways using fuzzy logic.

Materials and Methods

Let us formally describe BPMN diagrams using graphs:

$$BPG = (N, A), \quad (1)$$

where:

- N is the set of business process elements, such as events E , activities (i.e. tasks T , and sub-processes S), and gateways G ;
- A is the set of sequence-flows that connect business process elements.

In BPMN modeling, AND-Gateways $G_{and} \subseteq G$ are used to branch or merge threads of execution, ensuring that all outgoing or incoming branches execute in parallel without condition.

The procedure of AND-Gateways detection and extraction from BPMN files, processed as specially organized XML documents, is demonstrated in Fig. 2.

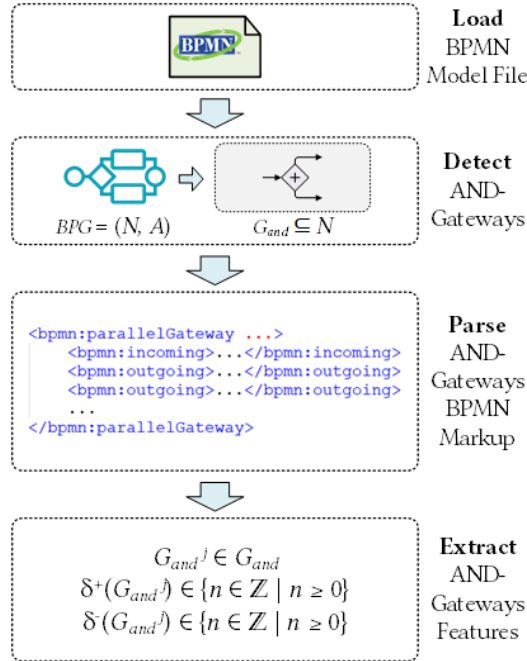

Figure 2: AND-Gateways detection and extraction from BPMN files

In BPMN modeling, an AND-Gateway must have either one input and two output flows for parallel branching, or two input and one output flow for synchronized execution:

$$R(G_{and}^j) = \begin{cases} 1, & \text{if } (\delta^+(G_{and}^j) = 1 \wedge \delta^-(G_{and}^j) = 2) \vee \\ & \vee (\delta^+(G_{and}^j) = 2 \wedge \delta^-(G_{and}^j) = 1), \\ 0 & \text{else,} \end{cases} \quad (2)$$

where:

- $\delta^+(G_{and}^j)$ is the number of incoming sequence flows to the AND-Gateway of the business process model $G_{and}^j \in G_{and}$, i.e. the in-degree of the AND-Gateway;
- $\delta^-(G_{and}^j)$ is the number of outgoing sequence flows from the AND-Gateway of the business process model $G_{and}^j \in G_{and}$, i.e. the out-degree of the AND-Gateway.

Formally, the quality of a BPMN model in terms of the degree to which the AND-Gateways comply to the modelling rules, according to ISO 9001, can be represented using as follows:

$$Q(G_{and}) = \frac{1}{|G_{and}|} \cdot \sum_{G_{and}^j \in G_{and}} R(G_{and}^j). \quad (3)$$

The general approach (Fig. 3) assumes detecting AND-Gateways in BPMN models, vectorizing their structural features, and using a fuzzy logic system to evaluate their compliance with modeling rules.

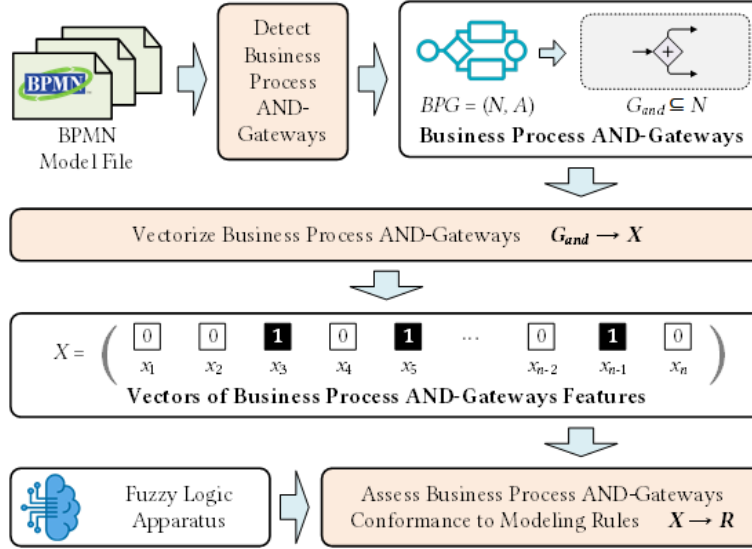

Figure 3: General approach to erroneous AND-Gateways detection and quality assessment

To assess the compliance of AND-Gateways in BPMN models with modeling requirements, a fuzzy logic apparatus is used, in which the vectorized characteristics of gateways are transformed into degrees of compliance using Gaussian membership functions, which allows flexible accounting for uncertainty and variability of structural configurations in business processes:

$$\mu(x; a, b, c) = ae^{-\frac{(x-b)^2}{2c^2}}, \quad (4)$$

where:

- x is the Gauss membership function argument;
- a is a parameter that determines the height of the curve peak, $a = 1$;
- b is a parameter that determines the position of the center of the “bell”;
- c is a parameter that determines the width of the “bell”.

In fuzzy logic, the AND operation is implemented through the minimum values of the membership functions of the input variables, while the OR operation is implemented through the maximum of their values:

$$\mu_{AND} = \min(\mu_1, \mu_2), \quad (5)$$

$$\mu_{OR} = \max(\mu_1, \mu_2), \quad (6)$$

where μ_1, μ_2 are some values of the membership functions of two fuzzy numbers.

Unlike simple predicate logic (2), fuzzy logic allows taking into account uncertainty and incomplete information in BPMN diagrams, which provides more flexible detection of erroneous AND-Gateways. Thus (2) and (3) should consider the use of Gauss membership function (4) and operations (5) – (6) to detect erroneous BPMN elements and assess the overall BPMN models quality.

The step function is used to provide binary classification values for detected AND-Gateways:

$$\mathcal{L} = \begin{cases} 1, & \text{if } \mu \geq 0.5, \\ 0, & \text{if } \mu < 0.5, \end{cases} \quad (7)$$

where:

- μ is some value of the membership function of a fuzzy number;
- \mathcal{L} is an activation function with a binary output $\mathcal{L} \in \{0,1\}$.

Results and Discussion

The proposed classifier (Fig. 4) based on fuzzy logic detects erroneous AND-Gateways in BPMN models by analyzing the input vector formed from the extracted business process graph features (1).

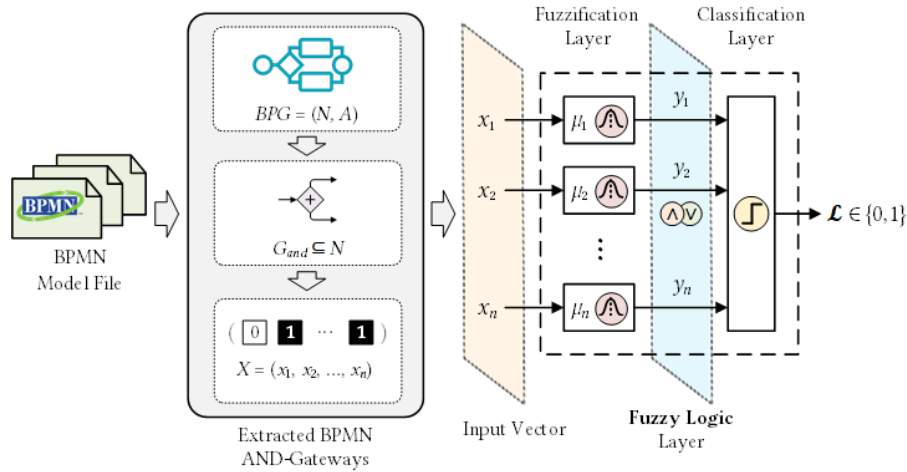

Figure 4: Proposed classifier used to detect erroneous AND-Gateways in BPMN models

Using the proposed classifier based on fuzzy logic, the large collection of 3729 BPMN models [5] is processed. In total, 3171 AND-Gateways were detected, among which 914 are classified as fault that do not correspond to the modeling rules (about 28.82%).

Conclusion and Future Work

This paper proposed the idea of fuzzy logic-based erroneous AND-Gateways detection and quality assessment of BPMN models. Taking into account the high impact of incorrect parallel constructs on workflows execution, possible errors and failures, the obtained results confirmed the significant amount (28.82%) of erroneous AND-Gateways.

In the future, the software will be developed to process large BPMN repositories and define quality measures for handled BPMN models from AND-Gateways and other elements viewpoint.

References

- [1] N. A. Panayiotou, K. E. Stergiou, V. P. Stavrou, Development of a Modeling Architecture Incorporating the Industry 4.0 View for a Company in the Gas Sector, In: Advances in Production Management Systems Towards Smart Production Management Systems: IFIP WG 5.7 International Conference, APMS 2019, Springer International Publishing, 2019, pp. 397–404. doi:10.1007/978-3-030-29996-5_46
- [2] D. T. Avila et al., An experiment to analyze the use of process modeling guidelines to create high-quality process models, In: Database and Expert Systems Applications: 30th International Conference, DEXA 2019, Springer International Publishing, 2019, pp. 129–139. doi:10.1007/978-3-030-27618-8_10.
- [3] Y. Falcone, G. Salaün, A. Zuo, Probabilistic Model Checking of BPMN Processes at Runtime, in: iFM 2022 – International Conference on integrated Formal Methods, Lugano, Switzerland, 2022, pp. 1–17. doi:10.1007/978-3-031-07727-2_11.
- [4] A. Khudori, T. A. Kurniawan, F. Ramdani, Quality Evaluation of EPC to BPMN Business Process Model Transformation, Journal of Information Technology and Computer Science 5(2) (2020) 207–220. doi:10.25126/jitecs.202052176.
- [5] BPMN for research. URL: <https://github.com/camunda/bpmn-for-research/>.