

Features of the Control of 12-pulse Compensated Controlled Rectifier

Butova Olga

National Technical University, "Kharkov Polytechnic Institute" (Ukraine)

olga_butova@ukr.net

Abstract — In this paper an overview of improved EMC controlled rectifiers is presented. In addition, characteristics of design of control systems of parallel 12-pulse compensated controlled rectifiers are identified.

I. INTRODUCTION

A significant amount of electric energy is consumed in a DC form, while the transmission of electric energy is done in AC form. The basic AC-DC converters circuits (rectifiers) used in today's industry and power engineering, traditionally are the full bridge (6, 12-pulse) circuits.

The main applications of these controlled rectifiers are power supply of DC motors, used in mine hoists, walking excavators, rolling mills, which require speed control, as well as electric transport applications.

Another area of application of AC-DC converters is electric technology (electrolysis, electroplating). According to technological process requirements such rectifiers should have: high reliability, the highest possible efficiency and the lowest consumption of reactive power to ensure electromagnetic compatibility with the mains [1].

Rectifiers are also used as converters for superconducting magnetic energy storage (Superconducting Magnetic Energy Storage - SMES), which provide the power transfer between the superconducting coils and the AC system [2], [3], [4].

Essential disadvantage of most schemes is the reduction of power factor and distortion of the mains current waveform, that don't meet international standards, such as IEEE-519 [5].

There are various ways and methods to improve the EMC of converters, to reduce harmonics in the mains and to improve energy performance of AC-DC converters.

Usually, to reduce the distortion of the mains current waveform the traditional methods of suppressing harmonics are used: passive and active filters. Power resonant RLC-filters are usually configured to minimize certain harmonics (5th, 7th, 11th and 13th) (filter 1, Fig. 1). But, they do not have the flexibility and precision at setting parameters and have a large number of expensive and bulky elements that reduce technical and economic parameters of rectifiers.

Increase of pulse number of controlled rectifier circuit is realized by phase shifting transformers and autotransformers, which increases the weight, dimension and cost parameters, and can reduce the level of certain harmonics. Shift factor and power factor of the controlled rectifier are still low. The use in converters of AC-DC rectifiers with fully controlled switches (GTO, IGBT, IGCT) allows to control the reactive power. The problem of limitation of overvoltages arising from the interruption of transformer phase currents (switching energy), can be solved by using the capacitor filters connected to the rectifier input, which not only eliminate the

overvoltages in the switches, but also compensate the higher harmonics (filter 2, Fig. 1).

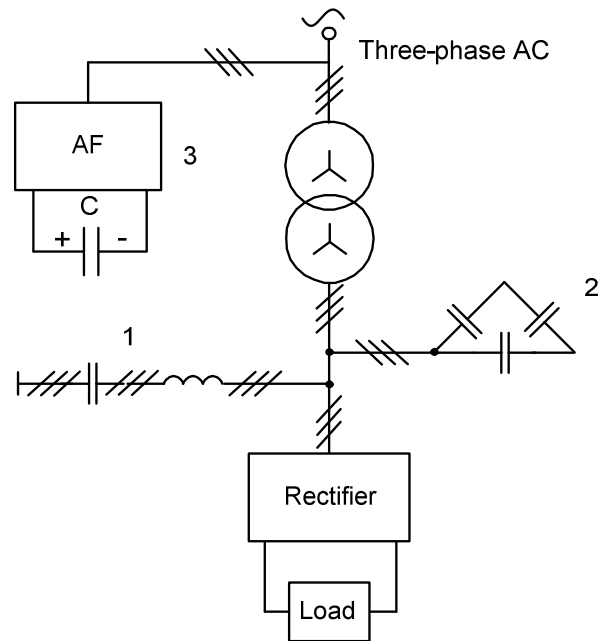

Fig. 1. Generalized controlled rectifier circuit.

The use of impulse control methods (for instance, PWM) in converters with fully controlled semiconductor switches allows to increase the power factor and to obtain a sinusoidal AC current. However, high switching frequency of power switches increases the dynamic switching losses in the power components, complicates the control system of the PWM converter switches and raises the level of electromagnetic interference and high frequency noise.

Currently, there is a tendency to reduce the required capacitance of input filter that is used to remove switching energy. Active power filter (AF) in the converter (filter 3, Fig. 1) allows to use output power to compensate the higher harmonics, instead of heavy and expensive power resonant filters.

It is possible to obtain close to unity power factor by an integrated approach to the EMC problems [6]. The increase of pulse number of converter systems based on the compensated controlled rectifiers (CCR) consisting of two three-phase bridge circuits, connected in series or in parallel, is used. The use of two bridge circuits (for thyristors and fully controlled switches) with simultaneous application of new control algorithms can improve the power factor (PF) while reducing total harmonic distortion (THD) [7], [8]. In the 12-pulse CCR, designed on the basis of the parallel connection of bridge circuits (BC), the diode bridge and capacitor C of AF

(Fig. 2) are used to remove the energy stored in the leakage inductance of the transformer.

II. FEATURES OF CONTROL SYSTEM

The control system of 12-pulse parallel CCR is more complex due to the presence of circulating currents flowing between the rectifier bridges. Control system requirements are determined by the requirements of the whole system: the maintenance of unity shift factor of the fundamental mains current with respect to voltage, current balancing in the bridge CCR, the suppression of harmonics in the mains current and maintaining constant current (voltage) of the load.

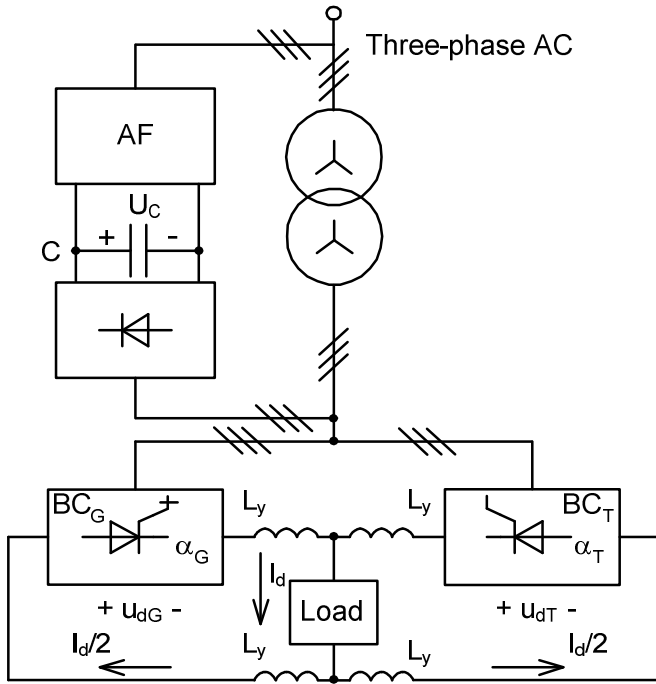

Fig. 2. The 12-pulse parallel CCR circuit.

Depending on the control algorithms of rectifier groups the CCR can be studied in basic mode - assuming instant switching or considering switching process of power switches. In the basic mode a symmetric control of rectifier groups is supported with the equality of the absolute values of the firing angles of the bridges

$$|\alpha_G| = \alpha_T \quad (1)$$

providing reactive power compensation [9]. Under the assumption of instantaneous switching of bridge switches or low angles of switching the average values of rectified current of each bridge $I_{dG} = I_{dT} = I_{dn}/2$. Waveforms of instantaneous rectified voltage are shown in Fig. 3.

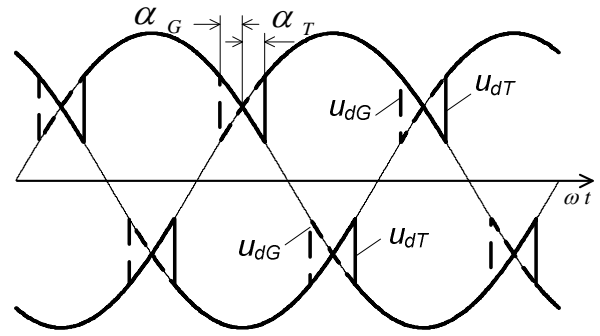

Fig. 3. Waveforms of instantaneous rectified voltages at instantaneous switching.

Given the process of switching of power switches, the mode of full reactive power compensation is achieved in the case of maintenance between the firing angles α_G and α_T , of a ratio [10]:

$$|\alpha_G| - \frac{\gamma_G}{2} = \alpha_T + \frac{\gamma_T}{2} \quad (2)$$

where γ_T and γ_G - respectively, the current commutation angles in the thyristor and fully controlled switches (Fig. 4):

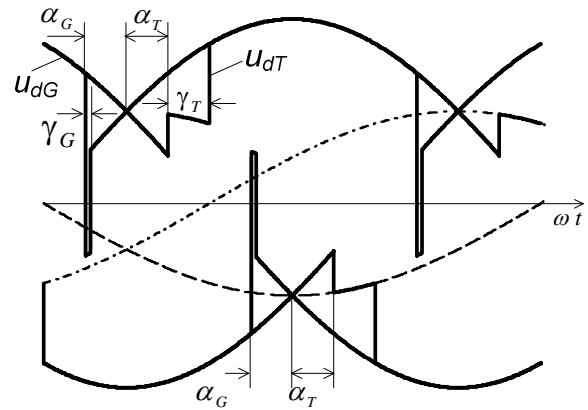

Fig. 4. Waveforms of instantaneous rectified voltage under switching.

Angles of the current commutation of GTO thyristors (γ_G) are determined from the expression:

$$\cos(\alpha_G) - \cos(\alpha_G + \gamma_G) + \gamma_G U_c^* = e_k I_d^* \quad (3)$$

where $e_k = 0.1$ - the relative value of short circuit voltage of the converter transformer;

$I_d^* = I_d / I_{dn}$ - relative value of the load current as a part of rated current;

$U_c^* = U_c / E_{am}$ - relative value of the voltage on the capacitor (for further study a value $U_c^* = \sqrt{3}$ is accepted).

Angles of the current commutation of GTO-thyristors (γ_T) are defined by the expression:

$$\cos(\alpha_T) - \cos(\alpha_T + \gamma_T) = e_k I_d^* \quad (4)$$

As can be seen from (3) and (4) the switching angles are not equal (Fig. 5). The consequence of that is asymmetric control of rectifier bridges.

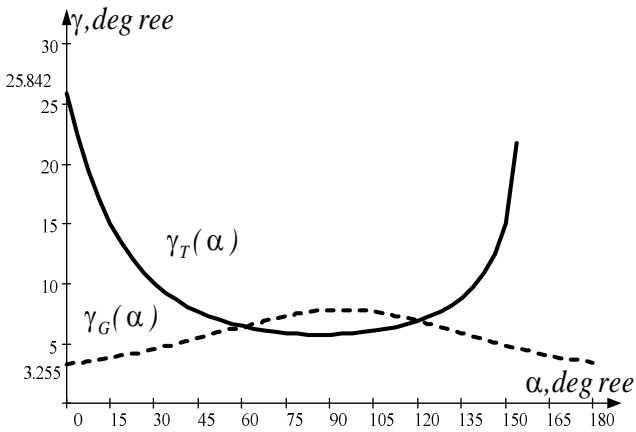

Fig. 5. Relationship between switching angles and firing angles.

In full reactive power compensation mode it is necessary to maintain zero phase shift between the voltage and current sinusoids ($\cos \varphi = 0$). In this case, the maintenance of the output parameters of the converter is done in accordance with (2), but due to the inequality of voltages at the output of rectifier bridges their currents are also not equal.

While maintaining equal currents of bridges and stabilizing the load current the full compensation of reactive power can be achieved only with the AF.

These control laws are realized by multiloop control system with subordinate regulation (Fig. 6). The control circuit includes automatic regulators: the output parameters (ROP), circulating currents (RCC) and power factor (RPF) regulators. Depending on the load of the converter, the formation of angles in the control system can be done with consideration of different priorities.

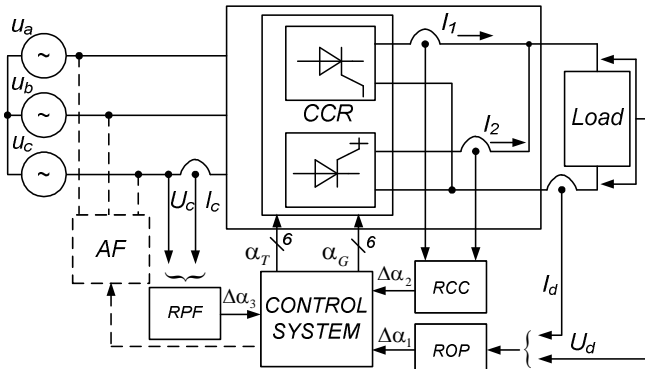

Fig. 6. Generalized control system of 12-pulse parallel CCR.

III. SIMULATION RESULTS

Verification of theoretical results was carried out by modelling the 2 MW capacity converter, using the package Matlab/Simulink.

Fig. 7 shows the waveforms of a symmetric mode control of two bridges, i.e. control law corresponds to (1), and only ROP regulator works. From the waveforms it can be seen: the currents of bridges I_1 and I_2 are not equal in value, shape, and the rectified voltages U_{dT} and U_{dG} of output bridge are

different from the traditional ones. Switching in GTO-thyristors increases average rectified voltage U_{dT} of bridge BC_T (Fig. 2), and switching in the thyristor bridge - reduces the rectified voltage U_{dG} of bridge BC_G .

Thus, when determining the control action it is necessary to consider the mutual influence of the individual converters through the power transformer. In this case, with the same values of firing angles $\alpha_T = 15^\circ$ the phase shift φ between the input current and voltage is close to zero, but the bridge currents are $I_1 = 2000$ A and $I_2 = 500$ A with $I_{dn} = 2500$ A.

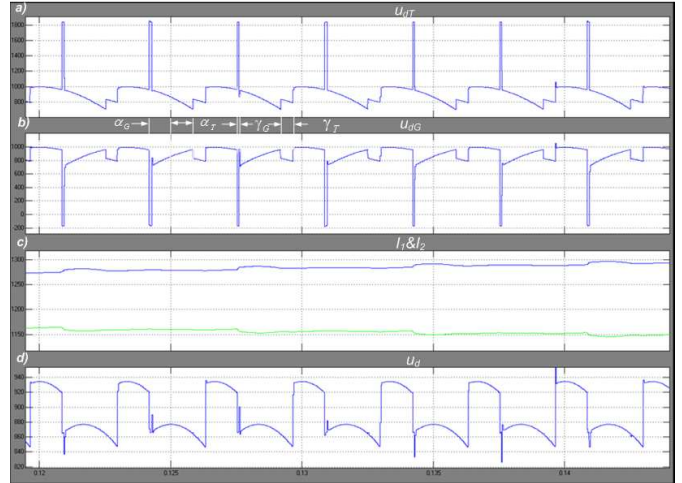

Fig. 7. Oscillograms of the output parameters for symmetric control $|\alpha_G| = \alpha_T$: a) - rectified voltage U_{dT} ; b) - rectified voltage U_{dG} ; c) - currents of bridges I_1 and I_2 ; d) - rectified voltage U_d .

Relationships of the main parameters of the scheme (PF, DPF, THD) from the firing angle (Fig. 8) show the necessity to maintain a constant current of the two rectifier bridges.

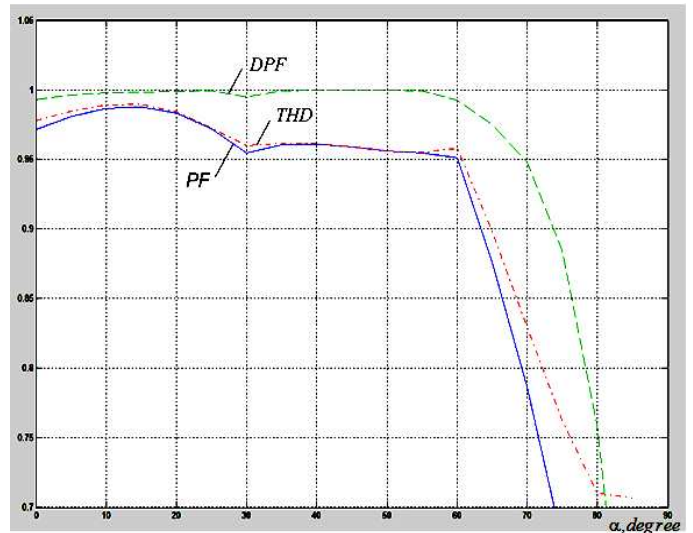

Fig. 8. Relationships of PF, DPF and THD from the firing angle.

In case of equal currents of bridges (Fig. 9) the firing angles of rectifier bridges are different, which leads to the phase shift between the input current and voltage: displacement power factor $DPF=0,998$ (at $\alpha_T = 15^\circ$).

The compensation of the shift can be made by SAF. Energy to power the active filter can be supplied from a capacitor used to remove the switching power.

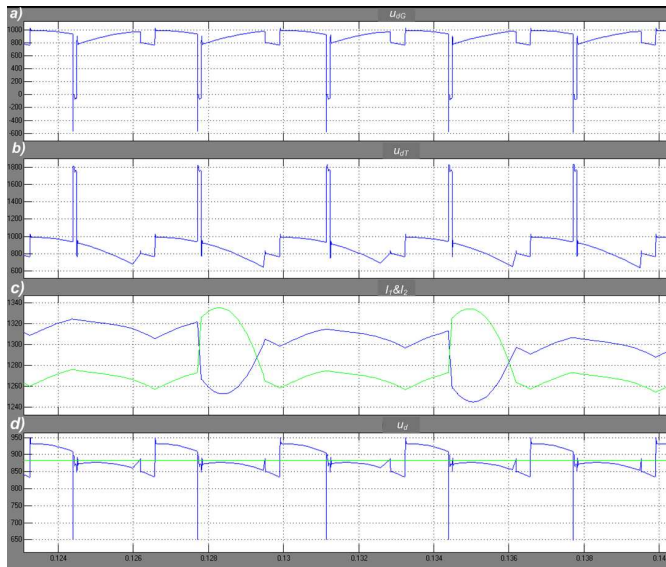

Fig. 9. Oscillograms of the output parameters for balancing the currents in the bridges CCR: a) - rectified voltage U_{dG} ; b) - rectified voltage U_{dI} ; c) - currents of bridges I_1 and I_2 ; d) - rectified voltage U_d .

IV. CONCLUSIONS

It can be concluded that in recent years the tendency of an integrated approach to the development of improved high-power rectifier topologies and their control systems to improve the EMC with a power mains is formed. This allows to solve several problems:

- improve the energy performance of the system (power factor, shift factor and efficiency);
- decrease the level of higher harmonics of the input current of the rectifier;
- reduce dimensions and weight of the rectifiers.

Perspective are the converters based on CCR, despite the growing complexity of power equipment and complexity of control systems design.

The control laws in CCR should be based on multi-criteria optimization of control. The criteria can be the maximum power factor, the minimum unbalance of current of bridges,

the maximum system efficiency. Optimization is carried out in the conditions of changing performance of control object and parameters of the mains.

The increasing complexity of control law, the simultaneous obtaining the maximum PF and minimum values of current difference of bridges I_1 and I_2 , and the possible use of the AF can not only provide a zero DPF, but also make a correction of the mains current.

REFERENCES

- [1] В. Бобков, А. Бобков, В. Копырин. Силовая преобразовательная техника для электротехнологических установок постоянного тока. «Силовая электроника», 2004. - № 1 – 66-69 с.
- [2] I. J. Iglesias, J. Acero, and A. Bautista, "Comparative study and simulation of optimal converter topologies for SMES systems," *IEEE Trans. Appl. Supercond.*, vol. 5, no. 2, pp. 254–257, Jun. 1995.
- [3] Q. Jiang and M. F. Conlon, "The power regulation of a PWM type superconducting magnetic energy storage unit," *IEEE Trans. Energy Convers.*, vol. 11, no. 1, pp. 168–174, Mar. 1996.
- [4] X. Jiang, X. Chu, X. Wu, W. Liu, Y. Lai, Z. Wang, Y. Dai, and H. Lan, "SMES system for study on utility and customer power applications," *IEEE Trans. Appl. Supercond.*, vol. 11, no. 1, pp. 1765–1768, Mar. 2001.
- [5] IEEE Std. 5 19-1992, "IEEE Recommended Practices and Requirements for Harmonic Control in Electrical Power Systems".
- [6] Бутова О. А. Анализ принципов построения систем управления многопульсными выпрямителями. // *Технічна електродинаміка*. – Київ, 2009. – Тем. випуск "Силова електроніка та енергоефективність". – Ч. 5, с. 59–65.
- [7] Бутова О.А., Жемеров Г.Г., Замаруев В.В. Исследование процессов двенадцатипульсного параллельного компенсированного управляемого выпрямителя // *Технічна електродинаміка*. – Київ, 2008. – Тем. випуск "Силова електроніка та енергоефективність". – ч.2. – С. 3-10. in Russian.
- [8] О.А. Бутова, В.В. Замаруев, В.А. Макаров, М.А. Шишкин. Улучшение энергетических показателей систем постоянного тока с 6-пульсными управляемыми выпрямителями. *Технічна електродинаміка*. – Київ, 2011. – Тематичний випуск "Силова електроніка та енергоефективність". – Ч.2. – с. 83-87.
- [9] Жемеров Г.Г., Ильина Н.А., Крылов Д.С. Преобразователь с единичным коэффициентом мощности // *Технічна електродинаміка*. – Київ, 2000. – Тема. випуск "Проблеми сучасної електротехніки". – Ч. 4. – С. 70-75.
- [10] Жемеров Г.Г., Крылов Д.С. Характеристики управляемого выпрямителя в режиме полной компенсации реактивной мощности // *Електричество*. – 2002. – №11. – С. 40-46.