

**OPTIMAL DESIGN OF GAS TURBINES FLOW PATHS CONSIDERING
OPERATIONAL MODES**

Anatoli Boiko

Turbine Projection Chair of the
National Technical University "KhPI"
Kharkiv, Ukraine
Email: anatoliboiko@yahoo.com

Yuri Govorushchenko

Turbine Projection Chair of the
National Technical University "KhPI"
Kharkiv, Ukraine

Aleksander Usaty

Turbine Projection Chair of the
National Technical University "KhPI"
Kharkiv, Ukraine

Oleksii Rudenko

Turbine Projection Chair of the
National Technical University "KhPI"
Kharkiv, Ukraine

ABSTRACT

A new technique for multi-parameter optimization of gas turbines flow paths considering a variable mode for their operation is presented. It allows the estimation of the influence of flow path optimization on performance parameters of gas-turbine units, such as power, efficiency, and fuel consumption. An algorithm for turbine flow path multi-criteria optimization that takes into account the gas-turbine unit operation mode is shown. Approaches to speed up the optimization process are described. Using this technique GT-750-6M low pressure turbine flow path optimization based on real working loads during one year is carried out and the results are analyzed. Due to optimization the unit efficiency was improved at all operating modes. The total fuel economy for considered period makes 50.831 t.

INTRODUCTION

The methodology of modern algorithms for axial turbines flow paths optimization, as a rule, is based on the principle of operational loading constancy [1, 2, 3, and 4]. The flow paths variants that were obtained with using of these algorithms have a high level of efficiency on design nominal modes. At the same time the experience shows that there is a whole class of gas-turbine units that operating in a wide range of operating loads. Such working conditions have a negative influence on the efficiency of gas turbines and highlight the need for

accounting for gas-turbine units' operating modes at the design stage of gas turbines' flow paths.

Currently there are few optimization algorithms, which can for the purpose of the accounting for turbine operation modes' influence the single geometrical parameters of individual turbine stages [5, 6]. However, to get the maximum effect from a multimode optimization it is required to include in consideration of a large number of optimized geometrical parameters for all stages of the flow path.

We present a new technique for the optimal design of gas turbines flow paths considering the factor of operating loads variability during optimization. The technique is based on the division of general optimization problems into a number of local problems according to the hierarchy of design objects [1, 2, 4, and 7] and includes different levels of detailed mathematical models and numerical methods for the search for the optimal solution.

The proposed approach to the solution of multimode optimization problems allows for the selection of the design with the best integrated performances for the considered range of modes for the chosen time interval from a set of alternative options in designs. Our optimizing technique allows for the consideration of complex problems of multi-parameter optimization (the number of optimized parameters is about $10n$, where n is a number of turbine stages) with a low computation time.

The following variable parameters can be chosen: mean diameters, blade heights, inlet and outlet angles, blade chords and blade numbers for nozzle and blade wheel cascades along the flow path of the turbine.

The results of the modernization of the flow path of the low pressure GT-750-6M (which is installed at the compressor station) taking into account real operational loadings for a calendar year, is given to illustrate our technique. Comparative numerical investigations have shown that the proposed modernization can essentially raise the integral characteristics of the specified gas-turbine unit in the entire range of working loadings (gains in useful capacity, depending on the operational mode, range from 0,9 % to 1,5 %). The fuel saving (of natural gas) for 177 days of unit operation amounts to 50.831 t.

NOMENCLATURE

Symbol

A	matrix of formal macromodel coefficients
b	blade chord
C_0	velocity equivalent to heat drop
d	mean diameter
G	mass flow rate
\bar{G}_{corr}	corrected mass flow rate
h	enthalpy
l	blade height
m	exponent defining the cascade twist law
n	rotor speed, modes number, factors number of formal macromodel
\bar{n}_{corr}	corrected rotor speed
N_V, N_X	domain boundaries of restrictions existence
N_c, N_r	numbers of design and regime parameters
P	pressure
\vec{q}	normalized vector \vec{x}
r	radius
t	time
T	temperature; period of time
U	tangential velocity
U/C_0	velocity ratio
\vec{v}	vector of functional restrictions
V, X	domains of functional and design restrictions existence
\vec{x}	vector of varied parameters of formal macromodel
\vec{Y}	vector of response functions with normalized components
Z	blade number
α_{0g}	inlet metal angle of nozzle cascade
α_1	outlet effective angle of nozzle cascade
β_{1g}	inlet metal angle of blade wheel cascade
β_2	outlet effective angle of blade wheel cascade
μ	weighting coefficient

Indices

*	designation of parameter of the stagnated flow
0, 2	inlet and outlet state variables
1, 2	nozzle or blade wheel; leading or trailing edges
c	constructive
cyl	cylinder

i, j, k, m	integer values for indexation
max	maximal value
min	minimal value
nom	parameter value at nominal mode
opt	optimal
r	regime

Abbreviations

$CCRP$	charts of change of regime parameters
DOE	design of experiment
FMM	formal macromodel
$FCLi$	formal macromodel coefficients of i-th level
GTU	gas-turbine unit
HPT	high pressure turbine
LPT	low pressure turbine
$OPLi$	optimal values of i-th level parameters
UCT	universal characteristics of turbine
$VPLi$	varied parameters of i-th level

OPTIMIZATION TECHNIQUE

Statement of flow path multimode optimization problem

The optimization problem consists of the search for acceptable solutions to a given problem, satisfying the restrictions of the design solution realization, which gives the maximum value of the criterion function. In a general view the multi-criteria and multi-parameter problem of the axial turbine flow paths' optimization regarding predicted operation modes under restrictions and inequalities is as follows:

$$\vec{Y}^{opt}(\vec{x}_c, \vec{x}_r = \vec{f}(t)) = \max \left(\int_0^T \left(\vec{Y}(\vec{x}_c, \vec{x}_r = \vec{f}(t)) \right) dt \right), \quad (1)$$

$$\vec{Y}(Y_1(\vec{x}_c, \vec{x}_r), Y_2(\vec{x}_c, \vec{x}_r), \dots, Y_n(\vec{x}_c, \vec{x}_r)), \vec{x}_c \in X, \vec{v}(\vec{x}_c) \in V, N_{Xmin} \leq |X| \leq N_{Xmax} < \infty, N_{Vmin} \leq |V| \leq N_{Vmax} < \infty$$

where, $\vec{x}_r = \vec{f}(t)$ – is a vector of regime parameters that varies in time.

Accounting for multi-criteria in the optimization problem

The gas turbine flow path is a very complex design object that is characterized by an entire set of quality factors. These are the components of the vector of output parameters \vec{Y} . Because of the existence of a large number of possible quality factors and different requirements for future turbine units, the majority of modern optimization tasks are, of necessity, multi-criteria.

In order to simplify the multi-criteria problem in the developed technique, a convolution of the vector quality criterion \vec{Y} with normalized components is used. The convolution is illustrated by the following equation:

$$\|Y(\vec{x}_c, \vec{x}_r)\| = \sqrt{\sum_{i=1}^n (\mu_i Y_i(\vec{x}_c, \vec{x}_r))^2}, \quad (2)$$

which is essentially the absolute value of the vector of individual quality criteria taking into account their weight factors (μ_i). Normalization of individual quality criteria (Y_1, Y_2, \dots, Y_n) is necessary for providing a principle of equivalent comparability of the vector \vec{Y} components with different physical meaning and different dimension.

A geometrical interpretation of the use of the proposed approach for the solution of the optimization task with two quality criteria is given in Fig. 1. As can be seen in in Fig. 1, the two-dimensional normalized criterion space of each variant of flow path design is characterized by the corresponding point, whose distance to the center of the coordinates is proportional to the value $\|Y(\vec{x}_c, \vec{x}_r)\|$. In essence, this form of convolution (2) is similar to the convolution of the ideal point method [8], which is in turn close to Germeyer's convolution [9]. As shown by Karpenko et al. [8], these convolutions, make it possible to find optimal solutions, both for convex and for non-convex Pareto sets.

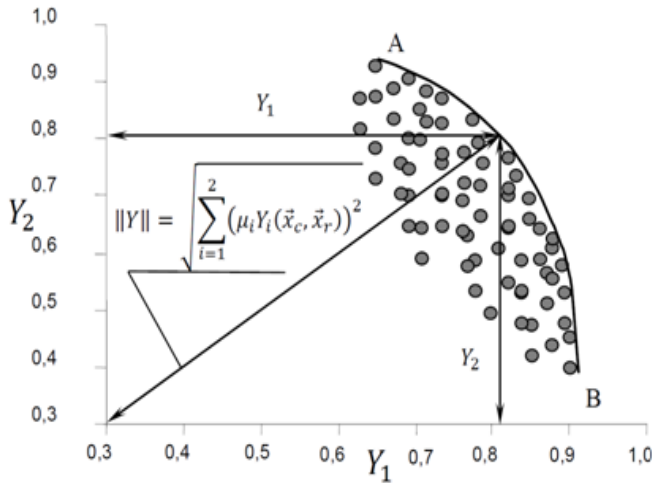

Fig. 1: Geometrical interpretation of optimization task solution with two quality criteria

Mathematical models

The use of the systems approach in the design process of the optimization technique leads to the necessity for detailed consideration of the investigated object. Therefore in the created optimizing algorithm for the solution of different problems several mathematical models are used.

For the modeling of thermodynamic processes in gas turbine cycles the universal program procedure «TopScheme» is used. Due to its object-oriented approach, «TopScheme» allows one to model any gas turbine cycles from accessible elements (the turbine, the compressor, the combustor, etc.). During the realization of thermodynamic calculations of GTU

thermal schemes on variable operation modes for the simulation of compressors' and gas turbines' performances in the program, «TopScheme» universal characteristics in dimensionless coordinates (similarity parameters) are used:

$$\begin{aligned} \bar{G}_{corr} &= G/G_{nom} \cdot P_{nom}^*/P^* \cdot \sqrt{T^*/T_{nom}^*}, \\ \bar{n}_{corr} &= n/n_{nom} \cdot \sqrt{T_{nom}^*/T^*}. \end{aligned} \quad (3)$$

The example of universal characteristics of an 2-stage axial turbine in dimensionless coordinates is shown in Fig. 2.

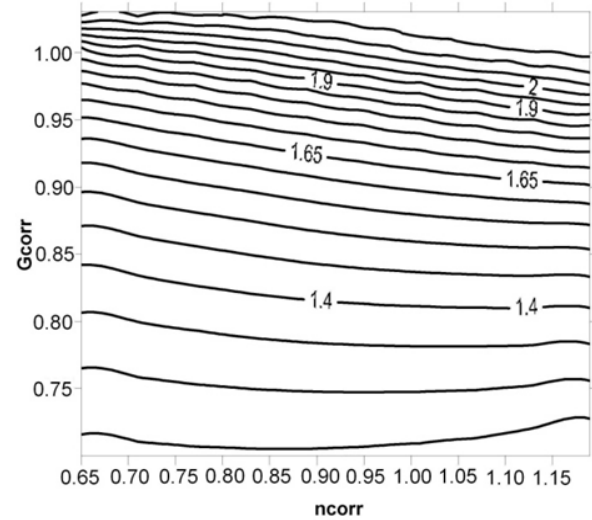

Fig. 2: Universal characteristic of high pressure turbine of GT-750-6M

For definition of the influence of geometrical and regime parameters on losses in nozzle and blade wheel cascades along the flow path, the mathematical model of a one-dimensional flow in a single turbine stage and in groups of stages is used. The stationary one-dimensional stream flow is demonstrated by the equations of energy and continuity, process and state, kinematic and closing relationships.

During the definition of turbine stages the efficiency levels following many kinds of energy dissipations are considered: losses in cascades; losses connected with the phenomena of an unsteady flow; losses connected with the presence of leaks through the radial gap and diaphragm seal; energy losses connected with disk friction, ventilation, tapping, humidity, presence of fastening wires. To calculate the above losses, several tested techniques are used: profile losses are estimated by the Craig and Cox method [10]; secondary losses – by the G. Yu. Stepanov method [11]; and losses from an unsteady flow – by the S. Z. Kopelev method [12].

The described models were improved by the Turbine Projection Chair of NTU "KhPI". During the improvement of these models special consideration was given to the issue of verification. As shown by numerous computational researches and the subsequent comparisons of the calculation results with experimental data and also with data from the technical

documentation using mathematical models meet the requirements of universality, adequacy, accuracy and efficiency.

To minimize the computing time for calculating the components of quality criteria vectors and functional restriction vectors at the stage of the search for the optimal solution, the developed optimization methodology assumes the replacement of the mathematical model describing the physical processes in the axial turbine flow path, by approximated dependences of components of vectors \vec{Y} in the form of a full square-law polynomial (by formal macromodels):

$$Y(q) = A_0 + \sum_{i=1}^n A_i q_i + \sum_{i=1}^n A_{ii} q_i^2 + \sum_{i=1}^{n-1} \sum_{j=i+1}^n A_{ij} q_i q_j. \quad (4)$$

Dependences in form (4) reflect only the formal relation between input and output parameters. For the creation of *FMM* of the quality criteria and functional restrictions, the methods of the *DOE* theory are used (three-level plans proposed by Box and Behnken [13], and saturated plans proposed by Rechtschaffner [14]). In this case, to determine the values of the observations vector components a mathematical model of one-dimensional flow in the flow path is used. This approach allows obtaining *FMM* by providing exact descriptions of the response function in the chosen hypercube.

During the solution of multimode optimization problems receiving *FMM* of a form (4) are functions of geometrical and regime parameters. Use of such *FMM* for finding the optimal solution leads to the need for multiple estimations of quality criteria for each test point, the number of calculations for each *FMM* is equivalent to the number of considered operating modes. Obviously, the increased number of calculations creates difficulties in the search for the best design. To solve this problem it is proposed to exclude known regime parameters from a vector of varied parameters of *FMM* (4). For an exception of regime parameters it is necessary to execute the integration of *FMM*. In this case new coefficients of *FMM* are obtained from the following dependence:

$$Y(q) = A_0 + \sum_{i=1}^{N_c} A_i q_i + \sum_{j=1}^{N_r} A_j \int_0^1 q_j(t) dt + \sum_{i=1}^{N_c-1} \sum_{k=i+1}^{N_c} A_{ik} q_i q_k + \sum_{j=1}^{N_r-1} \sum_{m=j+1}^{N_r} A_{jm} \int_0^1 q_j(t) q_m(t) dt + \sum_{i=1}^{N_c} \sum_{j=1}^{N_r} A_{ij} q_i \int_0^1 q_j(t) dt + \sum_{i=1}^{N_c} A_{ii} q_i^2 + \sum_{j=1}^{N_r} A_{jj} \int_0^1 q_j^2(t) dt. \quad (5)$$

The new formal macromodel of form (5) includes integrals from regime parameters which can be calculated by knowing

the regime parameters curves $q_j(t)$ and it can be transformed to the next form:

$$Y_m(q) = A_{0r} + \sum_{i=1}^{N_c} (A_{ir} q_i + A_{ii} q_i^2) + \sum_{i=1}^{N_c-1} \sum_{k=i+1}^{N_c} A_{ik} q_i q_k. \quad (6)$$

The *FMM* of a form (6) is more suitable for use in an optimization algorithm for the estimation of quality criteria since the given macromodel depends only on geometrical parameters which do not change values when the operating mode of the flow path changes. Thus, accounting for the expected schedule of change in operational loadings is carried out because regime parameters are included integrally into the new *FMM* coefficients.

As test rated researches have shown, use of *FMM* allows for a reduction of the search time for optimal solutions by approximately one hundred times, thus, the quality of gained solutions is not similar to those obtained with direct use of the model of one-dimensional flow in the flow path.

Search for the optimal solution

In the developed algorithms for gas turbines optimization, taking into consideration the variability of operation modes during solution of local and global optimization tasks, the points of Sobol sequences [15] are used. Development of the algorithm for the search for optimal solutions using the Sobol sequences is due to the fact that they lack many of the disadvantages of other methods, and have good adaptation to the solution of optimal design problems for turbomachines: make minimum demands on the smoothness of the criterion function; are suitable for the solution of multicriteria tasks taking into account functional and parametrical restrictions; allow for the solution of problems with a large number of optimized parameters. Examples of the use of Sobol sequence within modern optimization algorithms are [16, 17].

At the decision stage, the search at optimization "Cylinder" level and "Stage" level (Fig. 3), for each of the set of Sobol sequences points to, calculation of *FMM* of functional restrictions of form (4) is carried out. For points that satisfy these restrictions the calculation of *FMM* of quality criteria of form (6) is carried out. The obtained values of quality criteria fall within a range.

Studies have shown that due to the combined use of formal macromodelling and Sobol sequences the computational efficiency of the developed technique greatly exceeds the efficiency of the general methods.

The structure of optimization algorithms

The structure of developed algorithms of gas turbines flow path optimal design is shown in Fig. 3. As seen in Fig. 3, the solution of the general optimization task is separated into 3 local levels, each of which is intended for the solution of a specific range of tasks of acceptable complexity.

The "Cylinder" and "Stage" levels are intended for flow path geometrical parameters optimization. These levels have

their own objective functions, functional restrictions, design and regime parameters, obtained from thermodynamic calculation of the gas turbine cycle.

At the "Cylinder" level flow path meridional contours (d_1, d_2, l_1, l_2), and also inlet and outlet angles for nozzle and blade wheel cascades ($\alpha_1, \alpha_{0g}, \beta_2, \beta_{1g}$) are determined. As regime parameters of the "Cylinder" level the following can be involved: total input pressure and enthalpy (P_0^*, h_0^*), total or static output pressure (P_2^* or P_2), mass flow rate (G_0), rotor speed (n) and velocity ratio U/C_0 . The criterion of quality for the second level is internal efficiency or turbine compartment power. Functional restrictions at the "Cylinder" level are the mass flow rate of combustion products on the flow path input and the axial thrust operating on the rotor.

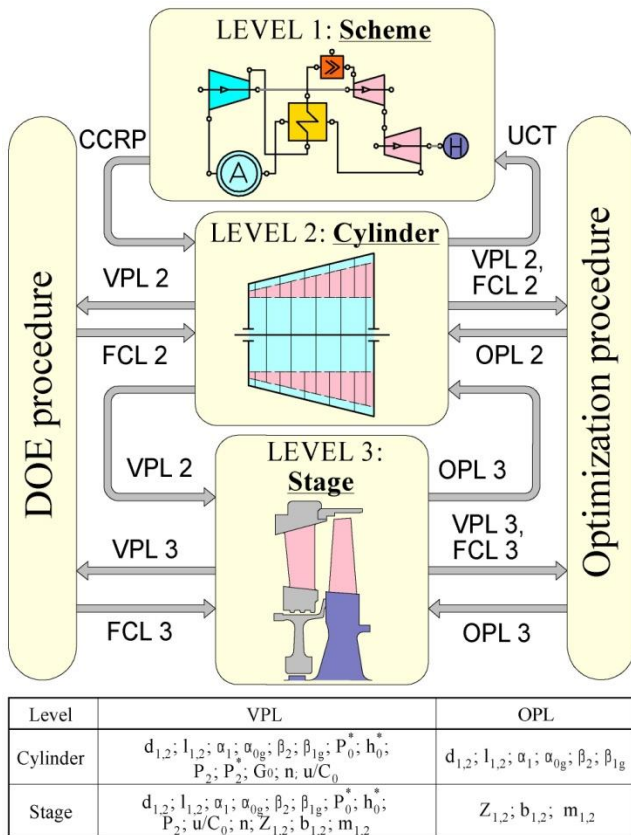

Fig. 3: The structure of optimal design technique

The lowest optimization level in the hierarchy is intended for searching for the optimal values for chords and blades numbers (b_1, b_2, Z_1, Z_2), and also optimal twist laws for nozzle and working blades (during quasi-three-dimensional optimization taking into account the slope and curvature of the lines of flow) which provide the maximum value of stage efficiency for the specified geometry ($d_1, d_2, l_1, l_2, \alpha_1, \alpha_{0g}, \beta_2, \beta_{1g}$). For blade rows twist laws definition angle values are set in the form of dependences:

$$r_1^{m_1} ctg \alpha_1 = const, \quad r_2^{m_2} ctg \beta_2 = const, \quad (7)$$

and varied parameter exponents m_1 and m_2 are used. The vector of regime parameters of the "Stage" level can be formed from: $P_0^*, h_0^*, P_2, U/C_0, n$. Functional restrictions at the "Stage" level are stresses on blades, disk and diaphragm.

Also for gas turbine flow paths with rotary nozzle blades the developed optimization technique allows for the definition of optimal values for the effective outlet angles of nozzle cascades (α_1) depending on the operation mode. After the solution of the general optimization task (a task of the base design parameters determination) determination of the angles α_1 as a function of the level of operational loading is carried out.

The working capacity and the reliability of the developed algorithm in many respects are provided by the presence of effective information exchange on various states of design object. Due to the proposed recursive connection between the designs levels all variations of the solutions of the highest optimization "Cylinder" level include the best solutions for the lower "Stage" level in the hierarchy of the optimization process.

The sequence of solutions for the general multimode optimization problem includes the following stages:

- 1) Thermodynamic calculation of *GTU* thermal scheme in the considered operation modes.
- 2) Generation of *FMM* of quality criteria and functional restrictions at the "Cylinder" and "Stage" optimization levels by means of *DOE* methods.
- 3) Search for optimal solutions at the "Cylinder" and "Stage" levels.
- 4) Verification of optimal solutions by means of a mathematical model of one-dimensional flow in the gas turbine flow path.
- 5) If necessary, perform additional iterations to refine the optimal solution (repeat steps 2-4 with a corresponding narrowing of the ranges of optimized parameters variation).
- 6) Determination of the influence of the performed optimization on: *GTU* performance parameters; thermodynamic parameters of the gas turbine cycle; characteristics of separate elements of the thermal scheme.

As initial data in the developed optimizations of algorithm results of preliminary design or parameters of existing gas-turbine units are used (if the problem of modernization of the existing unit is posed). Ranges of change in regime parameters are selected according to the supposed (probable) schedule of their change and remain constants in the process of iterations by more precise definition of optimal solutions. Ranges of change of constructive components of vector *FMM* are narrowed in the process of specifying iterations.

OPTIMAL DESIGN RESULTS

In the given section of work the example of developed algorithm application for optimization of low pressure turbines of GT-750-6M, taking into account real operating modes and the thermal scheme of the unit, is shown. The specified gas-

turbine unit is used at the compressor station as a driver of the gas-compressor unit.

The image of the GT-750-6M thermal scheme is given in Fig. 4. As can be seen from Fig. 4, GT-750-6M is a split-shaft gas turbine unit with waste-heat recovery.

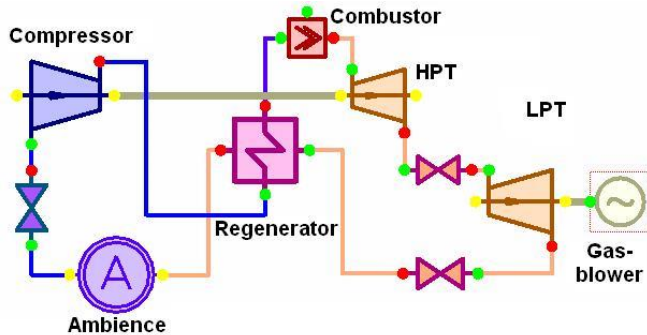

Fig. 4: The thermal scheme of GT-750-6M

Influence of gas turbine efficiency on performance parameters of a split-shaft gas turbine unit

The problem of flow path geometrical parameter multimode optimization with consideration of the thermal scheme of the unit is difficult and extremely labor intensive. At present, in the available literature, recommendations and examples of the solution of optimization problems in similar papers are practically not existent. Considering the above, for the purpose of the development of approaches to finding solutions to specified problems, preliminary research directed at the consideration of the influence of the efficiency of high and low pressure flow paths of GT-750-6M on its integral characteristics (fuel consumption, *GTU* efficiency, cycle initial parameters, etc.) have been carried out.

The increase of the efficiency of gas turbines flow paths is one of the preferable methods of increasing *GTU* efficiency and useful power. However, as studies have shown, in some cases the increase of the efficiency of gas turbine separately used in the thermal scheme within modernization does not produce the expected effect. It is connected with features of the configuration of turbines within *GTU*, and also with the interaction of turbines with other elements of the thermal scheme. The influence of gas turbines flow paths efficiency on *GTU* performance parameters using a GT-750-6M unit (Fig. 4) is considered as an example.

Increasing the efficiency of HPT

As can be seen from Fig. 4, *HPT* is located on the same shaft as the axial compressor and provides its work. The mass flow rate, temperature and pressure of combustion products behind *HPT* must be in strict conformity with the values necessary for generation by *LPT* power, set by the external consumer (the natural gas blower) in the current operation mode. An increase of *HPT* efficiency in the specified operating conditions of the turbine does not lead to the predicted improvement of the performance parameters of the turbine unit. For example, when saving the unit operation mode (useful

power, the power turbine rotor speed and the air parameters), the increase of *HPT* efficiency leads to an increase of its power. The additional power of *HPT* is transmitted through the shaft to the axial compressor, which leads to the redistribution of the main parameters of the gas-turbine cycle, namely:

- The increase of power for compressor drive causes an increase in compressor rotor speed, which causes an increase of the air flow rate and a slight increase of the compression ratio (compressor efficiency decreases because of the displacement of the compressor and *HPT* joint operation line takes place);
- the new air flow rate and pressure at the compressor outlet are superfluous for this thermal theme and cause a fall in combustion products at the combustion chamber outlet, which inevitably leads to a decrease in cycle thermodynamic efficiency.

The specified changes in the unit's thermal scheme nullify the effect expected from *HPT* flow path optimization. According to computational data the increase of *HPT* flow path efficiency with deceleration flow parameters of 1 % (up to 92,25 %) does not lead to a practical *GTU* efficiency increase.

Increasing the efficiency of LPT

The calculations show that the increase of *LPT* efficiency has a favorable effect on the performance parameters of the GT-750-6M. Considerable deviations of the gas-turbine cycle parameters from design are not observed in this case.

Thus, an increase in the efficiency of *LPT* flow path is the most rational variant of the GT-750-6M unit modernization. The specified modernization does not lead to an essential redistribution of the parameters of the gas-turbine cycle and therefore does not touch the expensive elements of the unit such as the compressor, combustor, regenerator and supercharger. There is no need to use new more expensive, heat-resistant materials for manufacturing optimized flow paths because these items do not the change the initial parameters of combustion products.

These studies were carried out for the GT-750-6M unit. Research results and conclusions are valid for all *GTUs* with a similar thermal scheme.

Results of optimization of the GT-750-6M low pressure turbine

In the process of optimization task solution all 3 levels of the offered optimization algorithms (Fig. 3) were involved. For thermodynamic calculations of the *GTU* thermal scheme on the considered operation modes the highest "Scheme" level in the hierarchy of optimization algorithms was used. The specified calculations allowed for the determination of values of regime parameters for a gas turbine flow path ($G_0, P_0^*, T_0^*, P_2^*, n$) necessary for following optimization at the "Cylinder" and "Stage" levels, and also the performance parameters of the *GTU* after the optimization of *LPT* flow path.

At the "Cylinder" level optimal values of geometrical parameters such as $d_1, d_2, l_1, l_2, \alpha_1, \alpha_{0g}, \beta_2, \beta_{1g}$ were defined. The quality criterion at the "Cylinder" level is the total power

of the turbine produced for a year of operation and the functional restriction – the combustion products mass flow rate through the flow path. A search for the numbers of nozzle and rotor blades (Z_1, Z_2), which correspond to the maximum value of stage internal efficiency, was performed at the "Stage" level. Regime parameters of optimization levels: P_0^*, T_0^*, P_2^*, n . The task was solved taking into account 177 real operation modes of the *GTU*. Each mode corresponds to unit operation for 24 hours. Unit loading for the considered period varied in a range from 52 to 73 % of the nominal mode, equal to 6 MW.

The solution of the assigned optimization task required 3 iterations for a more precise definition of an optimal design of the flow path. Optimized parameters variation ranges were narrowed for each subsequent iteration. The optimal values of geometric parameters of the flow path are given in Table 1.

The maps of the low pressure turbine efficiency as a function of the turbine expansion ratio and corrected rotor speed for the initial and the optimal flow path designs are given in Fig. 5. The executed optimization essentially led to an increase in the efficiency of the *LPT* flow path in all ranges of operation modes. In the nominal operation mode of the *GTU* the gain of *LPT* useful capacity, without mass flow rate increase, was 1,5 % (93,1 kW). Efficiency increases after optimization are caused by a decrease in the losses in nozzle and blade wheel cascades, exit energy losses, and a reduction of leakages in radial clearance. Therefore, in the nominal mode the velocity coefficient for nozzle and blade wheel cascades of an optimal flow path increased by 0,4 and 0,6 % respectively, the absolute velocity downstream rotor (C_2) decreased by 22 %, and the leakage in radial clearance decreased by 2,7 %. There was an increase of heat drop for nozzle cascades and a decrease of heat drop for blade wheel cascades (reaction decreased from 0.478 to 0.368). When the optimal design of the turbine works within the thermal scheme of the studied unit, the reduced value of velocity C_2 leads to a corresponding decrease of total pressure losses in the exhaust diffuser.

Table 1: Results of optimal design of the GT-750-6M high pressure turbine

Parameter	Initial design	Optimal design
1. Nozzle mean diameter – d_1 , m	0,970	1,046
2. Blade wheel mean diameter – d_2 , m	0,972	1,050
3. Nozzle blade height – l_1 , m	0,210	0,203
4. Working blade height – l_2 , m	0,211	0,222
5. Inlet metal angle of nozzle cascade – α_{0g} , deg	90,00	94,54
6. Inlet metal angle of blade wheel cascade – β_{1g} , deg	47,33	47,93
7. Outlet effective angle of nozzle cascade – α_1 , deg	20,67	19,00
8. Outlet effective angle of blade wheel cascade – β_2 , deg	25,18	24,12
9. Number nozzle blades – Z_1 , pcs	48	41
10. Number rotor blades – Z_2 , pcs	60	70

The assessment of performed optimization influence on *GTU* performance parameters showed that in the considered range of operational loadings change a positive gain of unit efficiency is observed. As it is evident in Fig. 6, the efficiency increment depending on the operation mode of *GTU* is from 0,09 to 0,27%. The fuel economy (of natural gas) for *GTU* with optimal *LPT* flow path depending on operation modes is given in Fig. 7. The total fuel economy for the considered period of 177 days amounted to 50.831 t.

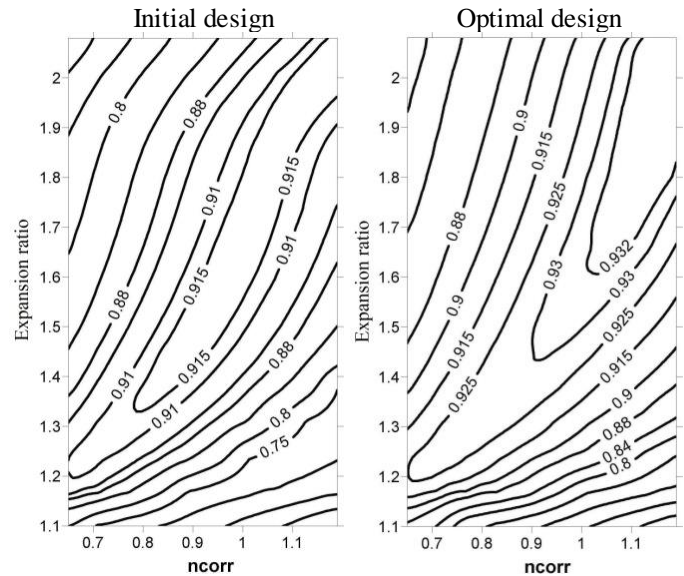

Fig. 5: The Efficiency of LPT of GT-750-6M

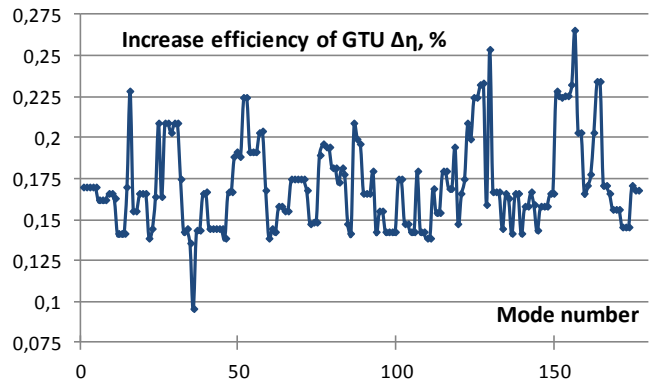

Fig. 6: The GTU efficiency increment depending on operation mode

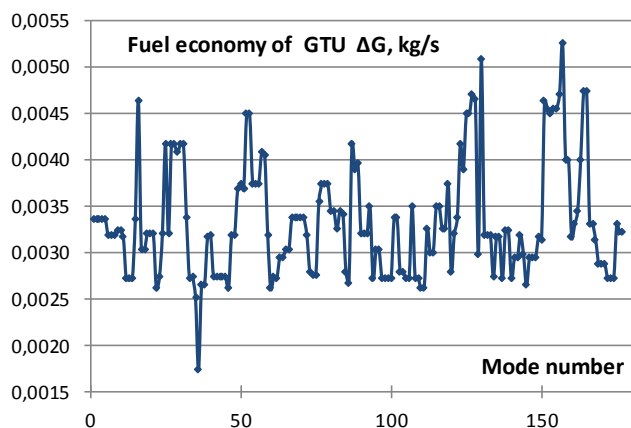

Fig. 7: Fuel economy for the GT-750-6M with optimal LPT by operation modes

The authors chose this GTU for their research because technical documentation and information were available for this unit for real operation modes. In spite of the positive results of the performed optimization, it should be noted that the performance parameters of GT-750-6M even after *LPT* optimization are quite low compared with modern units. The low value of unit efficiency (27.7% at design mode) is primarily caused by low cycle parameters (maximum cycle temperature is only 765°C, cycle compression ratio is 4,5). As can be seen from Fig. 6, a significant increase in *LPT* efficiency slightly affected the efficiency of the *GTU*. Therefore, in the paper the absolute values of unit efficiency before and after optimization for different operating modes are not given, since in this case such a comparison would be uninformative.

CONCLUSIONS

1. The offered technique of multilevel optimization of gas turbine flow paths allows for the presentation of the optimal design as a united complex of system-hierarchically coordinated optimization subsystems which provide the solution of "own" problems in various statements at each level of the hierarchy. Thus, providing the effective achievement of an overall purpose – obtaining the optimal solution for the *GTU* as a whole. Optimization algorithms created on this basis can be used for design of axial turbine flow paths for both new and modernized *GTUs*, with many types and ranges of application.

2. The advantage of the developed approach to the solution of optimal design problems is the possibility to consider a huge number of various combinations of turbine design parameters and provide a choice of the best, optimal variant taking into account the individual features of turbine unit operation.

3. Due to the use of the block-hierarchical design approach, formal macromodelling and Sobol sequences, the developed optimization algorithm makes minimum demands on computing resources and allows for the consideration of complex multiparameter problems in modern statements.

4. Inclusion of consideration of the thermal scheme of turbine units essentially expands the possibilities of optimization algorithms and allows optimization using the most global criterion – specific fuel rate (fuel rate for production of 1 kWh).

REFERENCES

- [1] Boiko, A.V., Govorushchenko, Yu.N., Yershov, S.V., and other, 2002, "Aerodynamic Computation and Optimal Projection of Turbomachine Flow Paths", NTU "KhPI", Kharkov, 356 p. (in Russian)
- [2] Hongde, J., Kepeng, X., Baoqing, L., and other, 2007, "A Precise Full-Dimensional Design System for Multistage Steam Turbines", *ASME Turbo Expo 2007*, GT2007-27195, 10 p.
- [3] Kawagishi, H., Kudo, K., 2005, "Development of Global Optimization Method for Design of Turbine Stages", *ASME Turbo Expo 2005*, GT2005-68290, 9 p.
- [4] Prado, P., Panchenko, Y., Trepanier, J.-Y. and Tribes, C., 2005, "Preliminary Multidisciplinary Design Optimization System: a Software Solution for Early Gas Turbine Conception", *ASME Turbo Expo 2005*, GT2005-69021, 8 p.
- [5] Demeulenaere, A., Ligout, A. and Hirsch, C., 2004, "Application of Multipoint Optimization to the Design of Turbomachinery Blades", *ASME Turbo Expo 2004*, GT2004-53110, 8 p.
- [6] Arzumanov, A.M., Lapshyn, K.L., 2003, "Multimode optimization of steam turbine flow path taking into account of thermal scheme parameters change", *Thermal Engineering*, № 12, pp. 68–71. (in Russian)
- [7] Usaty, A.P., 1988 "Optimization of HPC of Powerful Steam Turbines", Approved Thesis for the Degree of Candidate of Technical Science, Kharkov Polytechnical Institute, Kharkov, Ukraine, 187 p. (in Russian)
- [8] Karpenko, A.P., Semenikhin, A.S., Mitina, E.V., 2012, "Review: population methods of Pareto set approximation in multi-objective optimization problem", *Electronic scientific and technical periodical Science and Education*, №4, 77-30569/363023, 36 p. (<http://technomag.edu.ru/doc/363023.html>, in Russian)
- [9] Germeyer, Yu.B., 1971, "Introduction in the theory of research of operations", Nauka, Moscow, pp. 220. (in Russian)
- [10] Craig, H.R.M., Cox, H.J.A., 1971, "Performance estimation of axial flow turbines", *Proc Instn. Mech. Engrs.*, Vol. 185, 32/71, pp. 407–424.
- [11] Stepanov, G.Yu., 1962, "Hydrodynamics of Turbomachine Cascades", GIFML, Moscow, pp. 512. (in Russian)
- [12] Kopelev, S.Z., Zikeev, V.V., 1979, "Aerodynamic losses in blade wheel cascades of turbines at unsteady flow", *Thermal Engineering*, № 8, pp. 40–44. (in Russian)
- [13] Box, E.P., Behnken, D.W., 1960, "Some new three-level Design for the Study of Quantitative Variables", *Technometrics*, № 4, pp. 455–475.

- [14] Rechtschaffner, R.L., 1967, "Saturated fractions of $2n$ and $3n$ factorial designs", *Technometrics*, № 9, pp. 569–575.
- [15] Sobol, I.M., 1985, "The points which uniformly fill a multidimensional cube", *Mathematics, cybernetics series*, Znanie, Moscow, №2, 32 p. (in Russian)
- [16] Moroz, L., Govorushchenko, Yu., Romanenko, L., Pagur, P., 2004, "Methods and tools for multidisciplinary optimization of axial turbine stages with relatively long blades", *ASME Turbo Expo 2004*, GT2004-53000, 10 p.
- [17] Keskin, A., Swoboda, M., Flassig, P.M., Dutta, A.K. and Bestle, D., 2009, "New optimization strategy for rapid industrial blade design", *Proceedings of the 8th European Turbomachinery Conference*, Graz, Austria, pp. 925-935.