

Загалом, всі чотири вищенаведені компанії пропонують доволі широкий функціонал, який багато у чому повторюється. Для того, щоб визначити сервіс, що найкраще підійде для вирішення конкретної задачі, можна скористатися безплатними пробними планами та порівняти результати їх роботи. Також не треба забувати про вартість використання сервісу – вона може визначатися, наприклад, кількістю запитів або перекладених чи проаналізованих речень.

Використані джерела:

1. <https://analyticsindiamag.com/what-is-machine-learning-as-a-service-mlaas/>
2. <https://cloud.google.com/natural-language/#which-natural-language-product-is-right-for-you>
3. <https://azure.microsoft.com/en-us/services/cognitive-services/>
4. <https://www.ibm.com/watson/services/natural-language-understanding/>
5. <https://aws.amazon.com/comprehend/>

APPLICATION OF PLC-BASED DISTRIBUTED CONTROL SYSTEM FOR TESTING FOULING MITIGATION AGENTS IN BIOFILM MEMBRANE BIOREACTOR

Vladyslav Shostak, Bohdan Shostak

Faculty of Science and Technology (REALTEK), Norwegian University of Life Sciences,
PO Box 5003, 1432. vladyslav.shostak@nmbu.no

Membrane bioreactors (MBR) is an exemplary practice of sustainable wastewater treatment. Novel methods and approaches incorporating MBR allow not only treat wastewater with excellent efficiency, but also recover nutrients, recycle water, recover energy and carbon. These benefits provide limitless opportunities for MBR integration in many fields of wastewater treatment.

Still, the MBR technologies promise a lot of gains, there is a long way ahead before the MBR will overrun the world wastewater market. The most deterrent factor for MBR technology is a membrane fouling – it is evident from modern publications regarding MBR, the biggest fraction of which relates to the issue of fouling. Numerous strategies for membrane fouling mitigation have been developed recently, starting from the upgrade of traditional mechanical cleaning, introducing adjustments in chemical cleaning and ending up in advanced biological methods for fouling control (Drews, 2010). Commonly applied chemical pre-treatment of water entering MBR has proved its reliability, enhanced treatment efficiency and ability to greatly prolong filtration time. However, it lacks sustainability, since chemical precipitation with conventional coagulants produces a large load of sludge, which is difficult for further handling due to low dewaterability and poor biodegradability, and exposure to Aluminium in food and drinking water rises risks of Alzheimer disease and dementia (Choy et al., 2014).

Chitosan is a natural biodegradable polyelectrolyte produced from shells of crustaceans. Chitosan proved to have the high binding ability for fats, fatty acids, polysaccharides, dyes and other organics which can contribute to biofilm growth and cause severe fouling of the membrane (Bina et al., 2009; Salehizadeh et al., 2018; W. Pontius, 2016). Thus, it is a promising idea to investigate the anti-fouling abilities of chitosan and compare it with conventional coagulants.

For the research our team assembled IFAS-MBR (Integrated Fixed-Film Activated Sludge) installation that imitates the process of real wastewater treatment plant. The principal drawing of installation is presented in figure 1. First, raw wastewater from the sewer is collected in equalization tank, then by peristaltic pump water is directed to aeration tank filled with plastic beads which imitate IFAS treatment system. Water after biological treatment step was split into three different lines. Line 1 (blue rectangle on the figure) played the role of control line – conventional coagulant aluminium sulfate $Al_2(SO_4)_3$ was applied to serve as the reference of fouling mitigation reagent. Line 2 (green rectangle) was used to test natural flocculant (chitosan). And in the Line 3 (yellow rectangle) electrocoagulation unit with tubular electrodes was integrated as a pretreatment. Coagulant, flocculant and pH adjusting reagent were dosed by peristaltic pumps. Then, in MBR chambers sludge was separated and periodically discharged via solenoid valves installed at the bottom of each reactor. Pressure drop on membranes during filtration was recorded using digital manometers (-100...+100 kPa, 0.25% accuracy). Filtrated water was collected in intermediate tanks before discharged to the sewer. Sludge was also stored in a collection tank (not shown at the figure) and partially returned to the aeration unit to maintain MLSS concentration in Aeration tank. Rest of sludge was discharged to the sewer.

To establish control over the installation and create the possibility for automatic operation, a special control unit was designed based on Siemens PLC (S7-1200). The unit allowed to control valves position (Open/Closed); pumps' start/stop, speed and rotation direction; and monitor pressure sensors and level switches. To adjust parameters manually, switch to different modes of operation and monitor current status of installation sensor panel HMI KTP700 (Siemens) was installed in tandem with S7-1200 PLC.

Data from digital manometers were collected in two ways. The first approach was based on the utilization of PLC internal memory which allows saving data with a limit up to 5 MB. The special block was created in TIA-Portal software for data-logging on Siemens PLC. In this way, TMP was recorded every 30 sec and then manually transferred to PC through PROFINET connection every 5 days. Afterwards, data-log was manually emptied.

The second approach was implemented using Python algorithm based on Snap7 library (Molenaar & Preeker, 2013), which allows PCs to communicate with S7 Siemens PLCs. The algorithm installed on Raspberry Pi establishes connection between Pi and PLC via PROFINET and allows recording of data obtained from PLC in Pi's memory. Pi was connected to university Wi-Fi, therefore providing the

possibility of remote control and monitoring of installation through “VNC viewer” software. Since Pi has significantly bigger memory reserve, TMP was recorded every 5 sec.

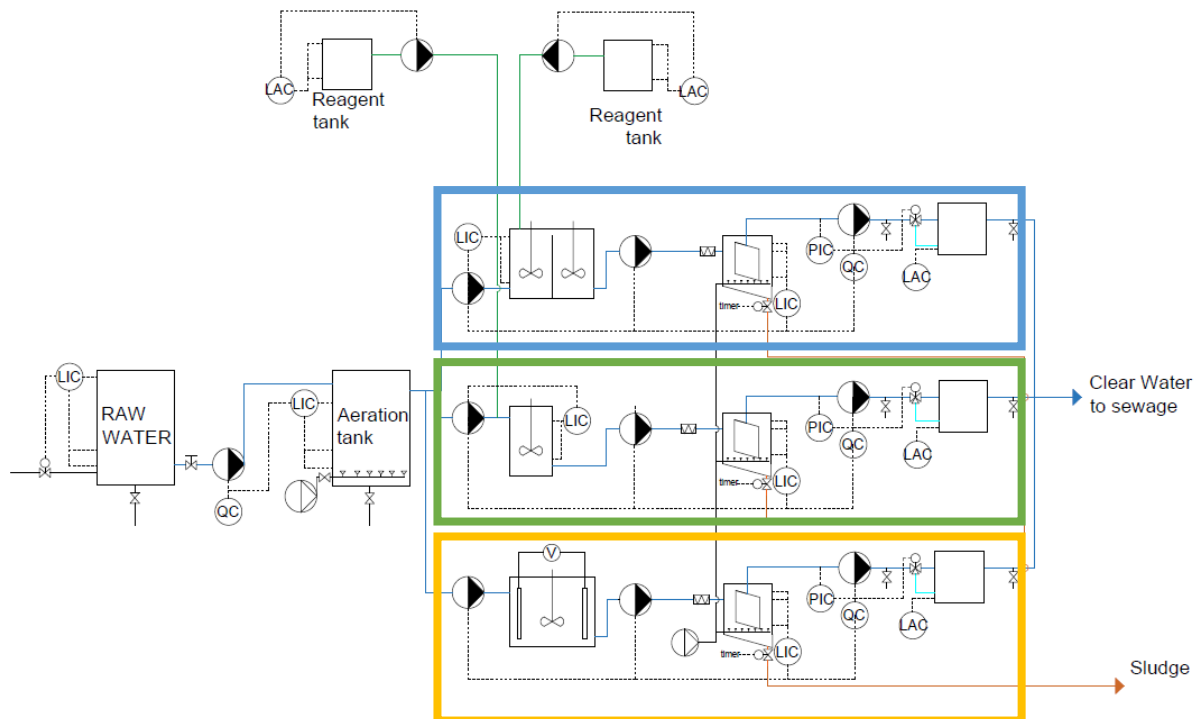

Fig. 1. Integrated Fixed-Film Activated Sludge Membrane bioreactors (IFAS-MBR) installation simulating the process of real wastewater treatment plant. The upper line (Line 1) plays the role of reference line with conventional coagulant of aluminium sulfate $Al_2(SO_4)_3$ as fouling mitigation reagent. The central line (Line 2) is used to test natural flocculant (chitosan). The lower line (Line 3) of electrocoagulation unit with tubular electrodes is integrated as a pretreatment

Peristaltic pumps due to their construction are known to create sinusoidal pressure trend over time. Such feature produces a considerable noise in obtained data. To filter this noise Fitting Curve Toolbox in MATLAB was utilized (MathWorks, 2019).

Despite outstanding aggregating abilities, the results of the study show that chitosan is not so efficient in terms of fouling mitigation comparable to conventional aluminium sulfate. Moreover, low concentration of chitosan can accelerate fouling in MBR and high doses need to be applied to overcome dose range when chitosan acts as fouling enhancer. Reason for this is unclear and further study is needed, however findings from different research state the possibility of more intensive fouling due to low microbial protein removal by chitosan. The result of the study asserts that at optimal dosing chitosan is about 2.5 less effective than aluminium sulfate in terms of fouling mitigation. Results comparing fouling mitigation abilities of Aluminium sulfate and Chitosan presented in figure 2.

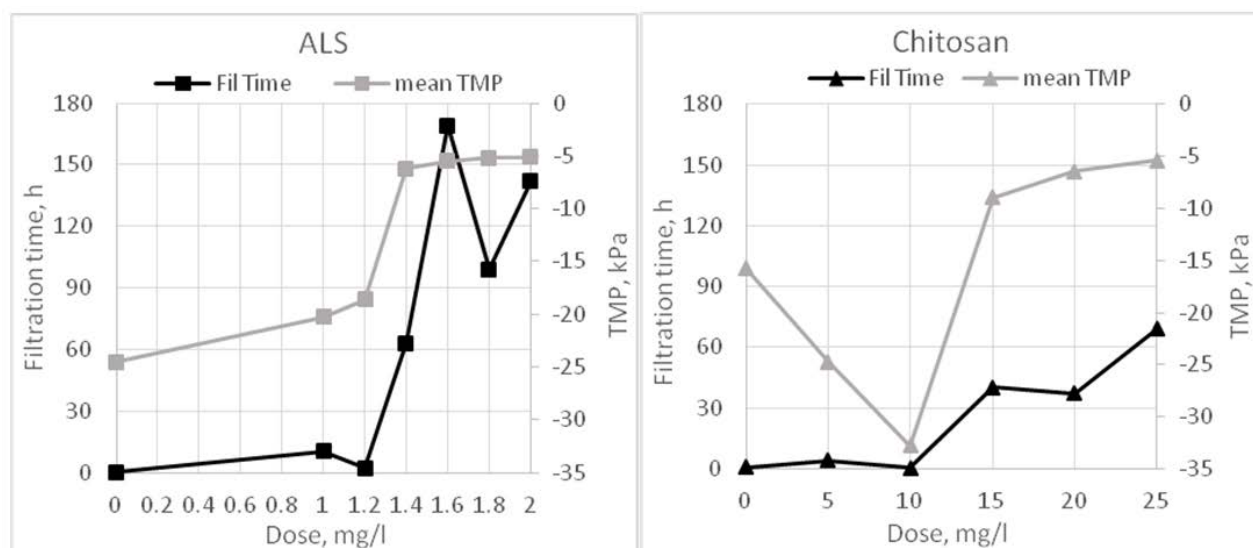

Fig. 2. Comparing the performance of ALS and Chitosan as anti-fouling agents. Filtration time is time for which TMP is increased by 1.5 times comparable to starting values

List of references:

Bina, B., Mehdinejad, M. H., Nikaeen, M., & Attar, H. M. (2009). EFFECTIVENESS OF CHITOSAN AS NATURAL COAGULANT AID IN TREATING TURBID WATERS, 6(4), 247–252.

Choy, S. Y., Prasad, K. M. N., Wu, T. Y., Raghunandan, M. E., & Ramanan, R. N. (2014). Utilization of plant-based natural coagulants as future alternatives towards sustainable water clarification. *Journal of Environmental Sciences (China)*, 26(11), 2178–2189. <https://doi.org/10.1016/j.jes.2014.09.024>

Drews, A. (2010). Membrane fouling in membrane bioreactors-Characterisation, contradictions, cause and cures. *Journal of Membrane Science*, 363(1–2), 1–28. <https://doi.org/10.1016/j.memsci.2010.06.046>

MathWorks. (2019). Curve Fitting Toolbox - MATLAB. Retrieved June 20, 2019, from <https://se.mathworks.com/products/curvefitting.html>

Molenaar, G., & Preeker, S. (2013). Python-snap7's documentation! Retrieved November 17, 2019, from <https://python-snap7.readthedocs.io/en/latest/>

Salehizadeh, H., Yan, N., & Farnood, R. (2018). Recent advances in polysaccharide bio-based flocculants. *Biotechnology Advances*, 36(1), 92–119. <https://doi.org/10.1016/j.biotechadv.2017.10.002>

W. Pontius, F. (2016). Chitosan as a Drinking Water Treatment Coagulant. *American Journal of Civil Engineering*, 4(5), 205. <https://doi.org/10.11648/j.ajce.20160405.11>