

MINISTRY OF EDUCATION AND SCIENCE OF UKRAINE  
NATIONAL TECHNICAL UNIVERSITY  
«KHARKIV POLYTECHNIC INSTITUTE»

S. D. Dimitrova, N. P. Girya, V. M. Burlayenko, O. O. Naboka

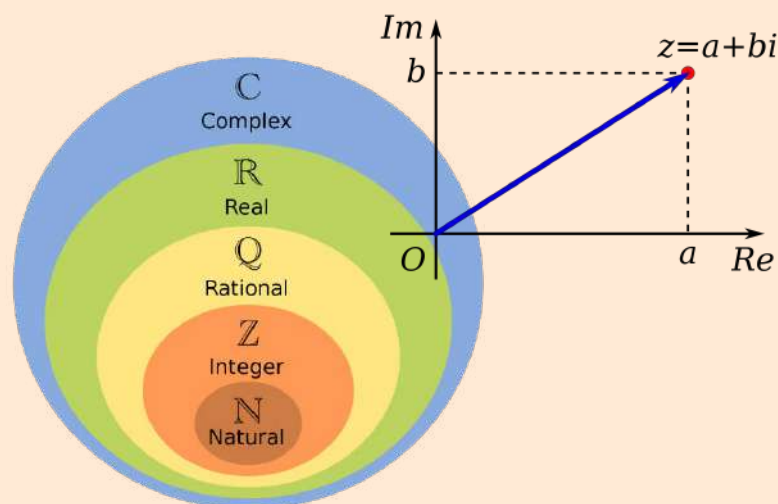
**COMPLEX NUMBERS AND THEIR APPLICATION TO  
REPRESENTING CURVES AND DOMAINS ON THE  
COMPLEX PLANE**

EDUCATIONAL-METHODOLOGICAL TEXTBOOK  
for individual work of students of technical specialties  
in all forms of education

С. Д. Дімітрова, Н. П. Гиря, В. М. Бурлаєнко, О. О. Набока

**КОМПЛЕКСНІ ЧИСЛА ТА ЇХ ЗАСТОСУВАННЯ ДЛЯ  
ПРЕДСТАВЛЕННЯ КРИВИХ І ОБЛАСТЕЙ НА  
КОМПЛЕКСНІЙ ПЛОЩИНІ**

НАВЧАЛЬНО-МЕТОДИЧНИЙ ПОСІБНИК  
для самостійної роботи студентів технічних спеціальностей  
усіх форм навчання



Kharkiv  
NTU «KhPI»  
2024

МІНІСТЕРСТВО ОСВІТИ І НАУКИ УКРАЇНИ  
НАЦІОНАЛЬНИЙ ТЕХНІЧНИЙ УНІВЕРСИТЕТ  
«ХАРКІВСЬКИЙ ПОЛІТЕХНІЧНИЙ ІНСТИТУТ»

S. D. Dimitrova, N. P. Girya, V. M. Burlayenko, O. O. Naboka

**COMPLEX NUMBERS AND THEIR APPLICATION TO  
REPRESENTING CURVES AND DOMAINS ON THE  
COMPLEX PLANE КОМПЛЕКСИ**

EDUCATIONAL-METHODOLOGICAL TEXTBOOK  
for individual work of students of technical specialties  
in all forms of education

С. Д. Дімітрова, Н. П. Гиря, В. М. Бурлаєнко, О. О. Набока

**КОМПЛЕКСНІ ЧИСЛА ТА ЇХ ЗАСТОСУВАННЯ ДЛЯ  
ПРЕДСТАВЛЕННЯ КРИВИХ І ОБЛАСТЕЙ НА  
КОМПЛЕКСНІЙ ПЛОЩИНІ**

НАВЧАЛЬНО-МЕТОДИЧНИЙ ПОСІБНИК  
для самостійної роботи студентів технічних спеціальностей  
усіх форм навчання

Затверджено  
редакційно-видавничою  
радою НТУ «ХПІ»,  
протокол  
№ 1 від 15.02.2024 р.

Харків  
НТУ «ХПІ»  
2024

УДК 517.53 (075)

C 64

Reviewers:

*M.E. Rezunenko*, Cand. Tech. Sci., Head of the Department of Higher Mathematics and Physics, Ukrainian State University of Railway Transport

*S.M. Reshetnikova*, Cand. Ph. Math. Sci., Assoc. Professor, National Technical University "KhPI"

C 64 Комплексні числа та їх застосування для представлення кривих і областей на комплексній площині : навчально-методичний посібник для самостійної роботи студентів технічних спеціальностей усіх форм навчання / С. Д. Дімітрова, Н. П. Гиря, В. М. Бурлаєнко, О. О. Набока. – Харків : НТУ «ХПІ», 2024. – 82 с. – Англійською мовою.

Навчально-методичний посібник присвячений важливій темі математичного аналізу – обчисленню функцій комплексної змінної. В ньому детально розглядаються фундаментальні теоретичні концепції та надаються розв'язки стандартних задач. Посібник також включає вправи для вивчення та серію завдань для індивідуальної роботи студентів.

Розраховано на студентів і викладачів вищих технічних навчальних закладів.

ISBN 978-617-05-0478-4

C 64 **Complex** numbers and their application to representing curves and domains on the complex plane : educational - methodological textbook for individual work of students of technical specialties in all forms of education / S. D. Dimitrova, N. P. Giryа, V. M. Burlayenko, O. O. Naboka. – Kharkiv : NTU «KhPI», 2024. – 82 p. – in English.

The educational-methodological textbook focuses on an important topic in mathematical analysis – the calculus of complex functions with a single variable. This textbook extensively explores the fundamental theoretical concepts and offers solutions to standard problems. It incorporates exercises for study and a series of tasks for individual student work.

Tailored for students and lecturers in higher technical educational institutions.

Fig. 39; Bibl. titles: 10

ISBN 978-617-05-0478-4

УДК 517.53

© С.Д. Дімітрова,

© Н.П. Гиря,

© В.М. Бурлаєнко,

© О.О. Набока,

© НТУ "ХПІ", 2024

## INTRODUCTION

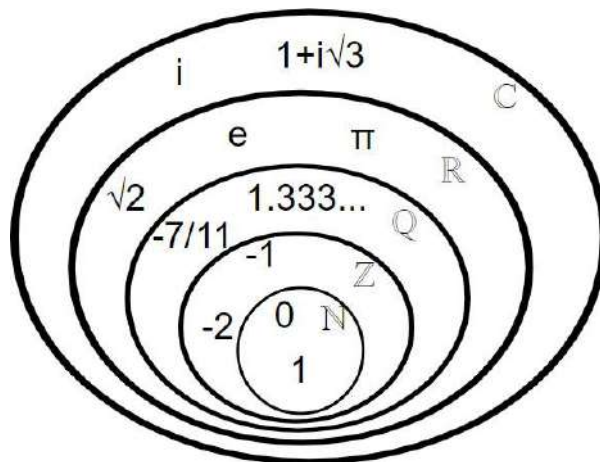
*Besides and even against the will of a particular mathematician, the imaginary numbers appear in the mathematical calculations over and over again, and become more and more widespread gradually, as the benefits of their applications are revealed.*

*Felix Klein*

Nowadays it is difficult to imagine a problem in engineering which solution does not involve complex analysis. The methods of complex analysis are rigorously applied when dealing with physical problems, theory of differential equations, problems in mathematical modeling, vibration theory etc. The notion of a complex number is supposed to have been invented to overcome the lack of real numbers for solving any quadratic equation.

Remember, that the set of real numbers does not suffice when solving a quadratic equation with real coefficients, whose determinant is negative. For instance, the equation  $x^2 + 1 = 0$  does not admit real roots. Thus, a necessity to expand the set of real numbers in such way, that the equation has solutions in the new numeric system, arises. The set of complex numbers is exactly such a set, i.e. it is the required expansion of the set of real numbers. Introducing complex numbers allowed for solving many challenging problems in mechanics, physics, mathematics, thermodynamics etc.

Representation of natural, integer, rational, real, and complex numbers by Euler diagram [4]:



The theory of complex numbers developed slowly. For the first time, apparently, imaginary quantities appeared in the famous work “Great Art, or on algebraic rules” by Italian mathematician Gerolamo Cardano (1545), who considered them unsuitable for use. The solution in radicals (without trigonometric functions) of a general cubic equation, when all three of its roots are real numbers, contains the square roots of negative numbers, a situation that cannot be rectified by factoring aided by the rational root test, if the cubic is irreducible; this is the so-called *casus irreducibilis* ("irreducible case"). This conundrum led Italian mathematician Gerolamo Cardano to conceive of complex numbers in around 1545 in his *Ars Magna*. Cardano and other Italian mathematicians, notably Scipione del Ferro, in the 1500s created an algorithm for solving cubic equations which generally had one real solution and two solutions containing an imaginary number. Since they ignored the answers with the imaginary numbers, Cardano found them useless.

Work on the problem of general polynomials ultimately led to the fundamental theorem of algebra, which shows that with complex numbers, a solution exists to every polynomial equation of degree one or higher [1-3]. Complex numbers thus form an algebraically closed field, where any polynomial equation has a root. Many mathematicians contributed to the development of complex numbers. The first person to appreciate complex numbers was the Italian mathematician, Rafael Bombelli. It was he who first described the simplest rules for operations with complex numbers: addition, subtraction, multiplication, and root extraction of complex numbers. A more abstract formalism for the complex numbers was further developed by the Irish mathematician William Rowan Hamilton, who extended this abstraction to the theory of quaternions. For a long time, it was not clear whether all operations on complex numbers lead to complex results or, for example, the extraction of nature could be the discovery of some new type of number. The problem of expressing the roots of a degree was solved in the works of De Moivre (1707) and Cotes (1722).

The symbol  $i = \sqrt{-1}$  was proposed by Leonhard Euler (1707 - 1783) in *Introduction to Calculus* (1746), who took the first letter of the Latin word *imaginarium*. He also extended all the standard functions, including the logarithm, to the complex domain. Euler also expressed in 1751 the idea of the algebraic closure

of the field of complex numbers. d'Alembert (1747) came to the same conclusion, but the first rigorous proof of this fact is due to Gauss (1799). Gauss and coined the term "complex number" in 1831, although the term had previously been used in the same sense by the French mathematician Lazar Carnot in 1803. The word complex (from the Latin *complexus*) means a connection, a combination, a set of concepts, objects, phenomena, etc., forming a single whole. During the 17th century, discussions continued on the arithmetic nature of imaginary numbers, the possibility of giving them a geometric justification. The technique of operations on imaginary numbers gradually developed. At the turn of the 17th and 18th centuries, a general theory of the roots of  $n$ th powers was built, first from negative, and then from any complex numbers, based on the following formula of the English mathematician A. De Moivre (1707): using this formula, it was also possible to derive formulas for cosines and sines.

Back in the 18th century, the world's leading mathematicians argued about how to find the logarithms of complex numbers. Then, with the help of complex numbers, it was possible to obtain many important facts related to real numbers, but the very existence of complex numbers seemed doubtful to many. Comprehensive rules for operations with complex numbers were also given in the 18th century by Euler.

The Swiss mathematician J. Bernoulli also used complex numbers to solve integrals. At the end of the 18th century, the French mathematician J. Lagrange was able to say that imaginary quantities no longer complicate mathematical analysis. With the help of imaginary numbers, they learned to express solutions of linear differential equations with constant coefficients. Such equations are encountered, for example, in the theory of oscillations of a material point in a resisting medium. During the 18th century, many problems were solved with the help of complex numbers, including applied problems related to cartography, hydrodynamics, etc., but there was still no rigorous rationale for the theory of these numbers. Therefore, the French scientist P. Laplace believed that the results obtained with the help of imaginary numbers are only guidance, acquiring the character of real truths only after confirmation by direct evidence of the sinus of multiple arcs.

At the end of the 18th century, at the beginning of the 19th century, a geometric interpretation of complex numbers was obtained. The Dane K. Wessel, the Frenchman J. Argan and the German K. Gauss independently proposed to depict a complex number as a point on the coordinate plane. Later it turned out that it is even more convenient to represent the number not by the point M itself, but by a vector going to this point from the origin. The English mathematician G.H. Hardy remarked that Gauss was the first mathematician to use complex numbers in 'a really confident and scientific way' although mathematicians such as Norwegian Niels Henrik Abel and Carl Gustav Jacob Jacobi were necessarily using them routinely before Gauss published his 1831 treatise. Augustin-Louis Cauchy and Bernhard Riemann together brought the fundamental ideas of complex analysis to a high state of completion, commencing around 1825 in Cauchy's case. Later classical writers on the general theory include Richard Dedekind, Otto Hölder, Felix Klein, Henri Poincaré, Hermann Schwarz, Karl Weierstrass and many others. Important work (including a systematization) in complex multivariate calculus has been started at beginning of the 20th century. Important results have been achieved by Wilhelm Wirtinger in 1927.

The geometric interpretation of complex numbers made it possible to define many concepts related to the function of a complex variable and expanded the scope of their application [5]. It became clear that complex numbers are useful in many issues where they deal with quantities that are represented by vectors on a plane: in the study of fluid flow, problems in the theory of elasticity.

Among the contributors to the development of complex analysis were eminent mathematicians such as A.-L. Cauchy, C.-F. Gauss, B. Riemann, K. Weierstrass. A specific system of numbers plotted as points in the plain was developed. The algebraic operations for such numbers were introduced. This new numeric system became a logical expansion of the set of real numbers and provided new efficient tools for mathematical solution of real-world problems [8,9].

The subject of *Complex numbers, plotting curves, and domains* is part of the Higher Mathematics curriculum for technical specialties. As many foreign students in Ukraine are proficient in English and more Ukrainian students are now

choosing English as their instructional language, there is a growing need for manuals in English. However, there is a scarcity of manuals in English for this course. This textbook is a translation and an essential extension of our previous manual [10] in theory, practical examples and individual tasks. The present work comprises the necessary theoretical minimum related to the notion of complex numbers and basic operations with complex numbers, plotting curves and domains in the complex plane. It contains numerous examples of solutions to typical problems and questions for self-control. In this textbook, one finds also the tasks for solving in practical classes and as students' homework, as well as test tasks aimed at developing practical skills in the topic considered. The sample variants of final tests for students in all forms of education are proposed.

This textbook is tailored for students in technical specialties who are studying complex analysis as part of the Higher Mathematics discipline. It also useful to lecturers preparing for practical classes in higher technical educational institutions. The textbook serves as a valuable resource for those seeking assistance in grasping the concept of complex numbers, understanding their geometrical interpretation, and mastering the analytical representation, plotting curves, and domains in the complex plane.

## 1. SET OF COMPLEX NUMBERS

**Definition 1.1.** A complex number  $z$  is an expression  $z = x + iy$ , where  $x, y \in R$ , and  $i$  is the *imaginary unit* satisfying the condition  $i^2 = -1$ . The number  $x$  is called the *real part* of the complex number  $z = x + iy$  and is denoted by  $\text{Re } z = x$ . The number  $y$  is called the *imaginary part* of the complex number  $z = x + iy$  and is denoted by .

**Definition 1.2.** The formula  $z = x + iy$  is referred to as an *algebraic representation* of the complex number  $z$ .

We denote the set of all complex numbers by  $\mathbb{C}$ :

$$\mathbb{C} = \{x + iy : x, y \in R, i^2 = -1\}.$$

Any complex number  $z = x + iy$  can be plotted as a point in a Cartesian coordinate plain with abscise  $x$  and ordinate  $y$ . The inverse is also true, i.e. each point in a plain with coordinates  $(x, y)$  corresponds to a complex number  $z = x + iy$ . Thus, there exists a one-to-one correspondence between the points in the  $Oxy$  plain and the set of complex numbers. For this reason, we refer to the  $Oxy$  as the *complex plain* below. This complex plane is denoted by the symbol  $\mathbb{C}$ , the same as we use for the set of complex numbers.

Let us study two particular cases of complex numbers.

1. Let  $y = 0$ , then  $z = x$ , i.e.  $z$  is a real number. Hence, each real number is also a complex number with zero imaginary part and can be plotted as a point on the  $Ox$  coordinate axis. For this reason, the  $Ox$  axis is also called the *real axis*. All real numbers comprise a subset of the set of complex numbers ( $R \subset \mathbb{C}$ ),
2. In the case  $x = 0$  we have fully imaginary numbers  $z = iy$ , which are plotted as points on the  $Oy$  coordinate axis. Thus,  $Oy$  is called the *imaginary axis*.

**Definition 1.3.** The complex numbers  $z_1 = x_1 + iy_1$  and  $z_2 = x_2 + iy_2$  are equal if  $x_1 = x_2$  and  $y_1 = y_2$ .

**Definition 1.4.** The numbers  $x + iy$  and  $x - iy$  are conjugated complex numbers and are denoted by  $z = x + iy$ ,  $\bar{z} = x - iy$  (see Fig. 1.1).

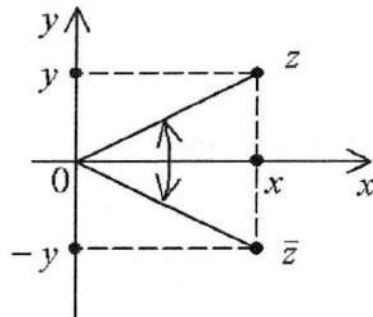


Fig. 1.1.

**Definition 1.5.** The formula  $z = r(\cos \varphi + i \sin \varphi)$  is the trigonometric representation of the complex number  $z$ .

The correlation between the algebraic and trigonometric representations of a complex number is given by the following formulae:

$$\begin{cases} x = r \cos \varphi \\ y = r \sin \varphi \end{cases}, \quad \operatorname{tg} \varphi = \frac{y}{x},$$

$$z = x + iy = r \cos \varphi + ir \sin \varphi = r(\cos \varphi + i \sin \varphi).$$

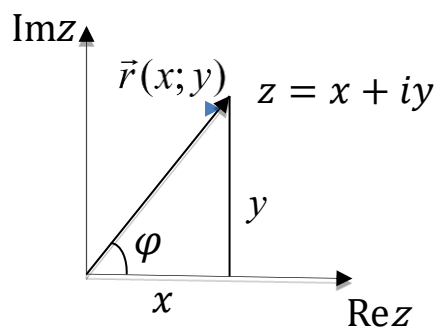


Fig. 1.2.

Any complex number  $x + iy$  can be identified with a radius-vector  $\vec{r}(x; y)$  and the representation of the number in the complex plain shown in Fig. 1.2.

Due to the latter representation the notions of the modulus and argument of a complex number can be naturally introduced.

**Definition 1.6.** The *modulus* of the complex number  $z = x + iy$  is the distance between the origin  $(0; 0)$  and the point  $(x; y)$  in the Cartesian coordinate plain. Thus, it equals the length of the radius-vector  $\vec{r}(x; y)$ . The modulus of the complex number  $z = x + iy$  can be computed by the formula:  $|z| = \sqrt{x^2 + y^2}$ .

The modulus of a complex number determined uniquely. We note that

$$-|z| \leq \operatorname{Re} z \leq |z|, \quad -|z| \leq \operatorname{Im} z \leq |z|,$$

which follows immediately from Definition 1.6 and Fig. 1.2. Equality  $\operatorname{Re} z = |z|$  holds if and only if  $z$  is real and  $z \geq 0$ .

**Definition 1.7.** The *argument* of the complex number  $z = x + iy$  is the angle  $\varphi$  between the positive direction of the  $Ox$  axis and the radius-vector  $\vec{r}(x; y)$ .

We note that for each complex number  $z = x + iy$ . Definition 1.7 introduces an infinite set of values called the argument of this number and denoted by  $\operatorname{Arg} z$ . Each two values of the argument of a complex number differ by a multiple of  $2\pi$ . To overcome this ambiguity the *principal value* of the argument from the interval  $(-\pi, \pi]$  is conventionally considered. This principal value is denoted  $\arg z$  and is unique in contrast to the set  $\operatorname{Arg} z$ .

To summarize the above:

$$\operatorname{Arg} z = \arg z + 2k\pi, k = 0, \pm 1, \pm 2, \pm 3, \dots, -\pi < \arg z \leq \pi.$$

**The argument of the complex number  $z = 0$  ( $x = 0, y = 0$ ) is not determined and its modulus is zero.**

The following relations hold:

$$\operatorname{tg}(\operatorname{Arg} z) = \frac{y}{x}, \quad \sin(\operatorname{Arg} z) = \frac{y}{\sqrt{x^2 + y^2}}, \quad \cos(\operatorname{Arg} z) = \frac{x}{\sqrt{x^2 + y^2}}.$$

We note that

$$\arg z = \begin{cases} \operatorname{arctg} \frac{y}{x}, & \text{for } x > 0; \\ \pi + \operatorname{arctg} \frac{y}{x}, & \text{for } x < 0, y \geq 0; \\ -\pi + \operatorname{arctg} \frac{y}{x}, & \text{for } x < 0, y < 0; \\ \frac{\pi}{2}, & \text{for } x = 0, y > 0; \\ -\frac{\pi}{2}, & \text{for } x = 0, y < 0. \end{cases}$$

Euler's Formula shows the relation between the imaginary power of exponent and trigonometric ratio *sin* and *cos* and is given by:

$$e^{i\varphi} = \cos \varphi + i \sin \varphi$$

By Euler's formula we arrive at the ***exponential representation of a complex number***:

$$z = r e^{i\varphi}, \quad r = |z|.$$

**Definition 1.8.** The complex numbers  $z_1$  and  $z_2$  are *equal* if they have equal modules and their arguments are either equal or differ by a value which is a multiple of  $2\pi$ :  $|z_1| = |z_2|, \operatorname{Arg} z_1 = \operatorname{Arg} z_2 + 2k\pi, k = 0, \pm 1, \pm 2, \pm 3, \dots$  .

It is easy to verify that

$$\arg \bar{z} = 2\pi - \arg z = -\arg z.$$

**Example 1.1.** Find the real and imaginary parts of the complex number

$$z = 5 - 6i.$$

*Solution:* by Definition 1.1 we have  $z = x + iy$ , where real part is  $\operatorname{Re} z = x = 5$ , imaginary part is  $\operatorname{Im} z = y = -6$ .

*Answer:*  $\operatorname{Re} z = 5$ ,  $\operatorname{Im} z = -6$ .

**Example 1.2.** Which of the following complex numbers are equal?

$$z_1 = -0,5 + \sqrt{4}i, \quad z_2 = -3 + 2i, \quad z_3 = -\frac{1}{2} + 2i, \quad z_4 = -\sqrt{9} + \sqrt{4}i,$$

$$z_5 = -\sqrt{9} + \sqrt[4]{16}i, \quad z_6 = \sqrt[3]{-27} + \sqrt[3]{8}i.$$

*Solution:* by Definition 1.3 two complex numbers are equal if and only if they have equal real and imaginary parts. For the given complex numbers, we have:  $z_1 = z_3$ ,  $z_2 = z_4 = z_5 = z_6$ .

*Answer:*  $z_1 = z_3$ ,  $z_2 = z_4 = z_5 = z_6$ .

**Example 1.3.** Plot the complex number  $z = -6 - 8i$  as a point in the complex plain.

*Solution:* the complex number  $z = -6 - 8i$  corresponds to the point in the complex plain with coordinates  $(-6; -8)$ , Fig. 1.3.

*Answer:*

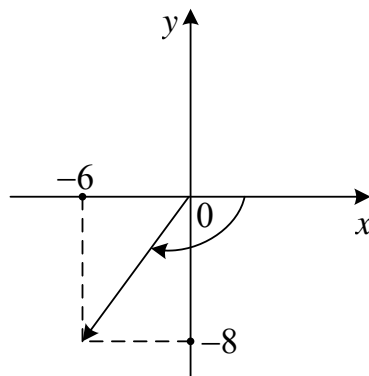


Fig. 1.3.

**Example 1.4.** Find the complex conjugate of the number  $z = 5 - 2i$ .

*Solution:* the complex conjugates are two complex numbers  $x + iy$  and  $x - iy$ , which differ only in the sign of their imaginary part.

*Answer:* Hence, the conjugate of the given complex number is the number

$$\bar{z} = 5 + 2i.$$

**Example 1.5.** Compute the modulus  $|z|$  and the principal value of the argument

$\arg z$  of the complex number  $z = 2e^{\frac{\pi i}{3}}$ .

*Solution:* by the exponential representation of a complex number

$$z = |z|e^{i \arg z}$$

*Answer:* we have  $|z| = 2$ ,  $\arg z = \frac{\pi}{3}$ .

**Example 1.6.** Compute the modulus and argument of the complex number

$$z = 1 + 2i.$$

*Solution:* for the complex number  $z = 1 + 2i$  we have:

$$x = \operatorname{Re} z = 1 > 0, \quad y = \operatorname{Im} z = 2, \quad \operatorname{tg}(\arg z) = \frac{\operatorname{Im} z}{\operatorname{Re} z} = \frac{y}{x} = \frac{2}{1} = 2, \text{ thus,}$$

$\arg(z) = \operatorname{arctg}(2)$ , and the approximate value is  $\operatorname{arctg}(2) \approx 63.43^\circ$ ;

$$\operatorname{Arg} z = \arg z + 2k\pi, \quad k = 0, \pm 1, \pm 2, \pm 3, \dots, \text{ thus,}$$

$$\operatorname{Arg} z = \operatorname{arctg}(2) + 2k\pi, \quad k = 0, \pm 1, \pm 2, \pm 3, \dots;$$

$$|z| = \sqrt{x^2 + y^2} = \sqrt{1^2 + 2^2} = \sqrt{5}.$$

*Answer:*  $\operatorname{Arg} z = \operatorname{arctg}(2) + 2k\pi, k = 0, \pm 1, \pm 2, \pm 3, \dots, |z| = \sqrt{5}$ .

**Example 1.7.** Find the trigonometric and exponential representation of the complex number  $z = \sqrt{2} - i\sqrt{2}$ .

*Solution:* the complex number  $z = \sqrt{2} - i\sqrt{2}$  is in its algebraic representation, Fig. 1.4. To find its trigonometric representation we compute its modulus and argument:

$$x = \operatorname{Re} z = \sqrt{2}, \quad y = \operatorname{Im} z = -\sqrt{2}, \quad |z| = \sqrt{x^2 + y^2} = \sqrt{(\sqrt{2})^2 + (\sqrt{2})^2} = 2,$$

$$\arg z = \operatorname{arctg} \left( -\frac{\sqrt{2}}{\sqrt{2}} \right) = -\operatorname{arctg} 1 = -\frac{\pi}{4}.$$

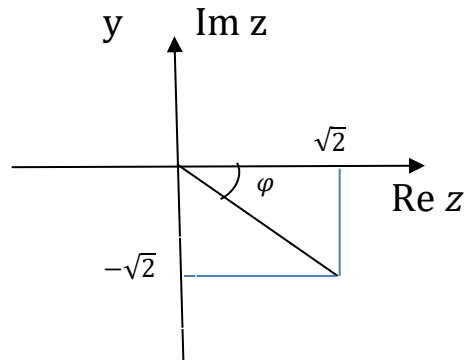


Fig. 1.4.

Thus, the trigonometric representation of the given complex number is

$$z = \sqrt{2} - i\sqrt{2} = 2 \left( \cos \left( -\frac{\pi}{4} \right) + i \sin \left( -\frac{\pi}{4} \right) \right).$$

We can simplify this expression using the properties of the trigonometric functions  $\cos \varphi$  and  $\sin \varphi$ :  $\cos(-\varphi) = \cos \varphi$ ,  $\sin(-\varphi) = -\sin \varphi$ , to arrive at the formula

$$z = 2 \left( \cos \frac{\pi}{4} - i \sin \frac{\pi}{4} \right),$$

which is a representation of the given complex number involving the trigonometric function, but it is not its trigonometric representation.

The exponential representation of the given complex number  $z$  is then:

$$z = 2e^{-\frac{\pi i}{4}}.$$

*Answer:*  $z = 2 \left( \cos \left( -\frac{\pi}{4} \right) + i \sin \left( -\frac{\pi}{4} \right) \right)$ ,  $z = 2e^{-\frac{\pi i}{4}}$ .

**Example 1.8.** Find the trigonometric and exponential representation of the complex number  $z_1 = 1$ ,  $z_2 = 2i$ ,  $z_3 = -3$ ,  $z_4 = -4i$ .

*Solution:* the complex number  $z_1 = 1$  is in its algebraic representation. To find its trigonometric representation we compute its modulus and argument:

$x = \operatorname{Re} z_1 = 1$ ,  $y = \operatorname{Im} z_1 = 0$ ,  $|z_1| = \sqrt{x^2 + y^2} = \sqrt{1^2 + 0^2} = 1$ ,  $\arg z_1 = 0$  (the number lies directly on the real positive semiaxis)

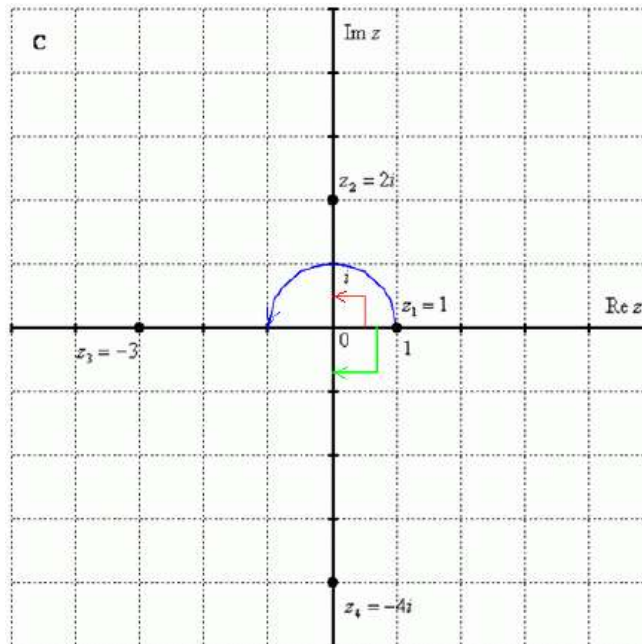


Fig. 1.5.

Thus, the trigonometric representation of the given complex number  $z_1 = 1$  is

$$z_1 = 1 = 1(\cos 0 + i \sin 0).$$

The exponential representation of the given complex number is then:  $z_1 = e^{0i}$ .

Let's represent the number  $z_2 = 2i$  in trigonometric and exponential form:

$$x = \operatorname{Re} z_2 = 0, \quad y = \operatorname{Im} z_2 = 2, \quad |z_2| = \sqrt{x^2 + y^2} = \sqrt{0^2 + 2^2} = 2, \quad \arg z_2 = \frac{\pi}{2}.$$

Thus, the trigonometric representation of the given complex number is

$$z_2 = 2i = 2 \left( \cos \frac{\pi}{2} + i \sin \frac{\pi}{2} \right).$$

The exponential representation of the given complex number is then:  $z_2 = 2e^{\frac{\pi}{2}i}$ .

Let's represent the number  $z_3 = -3$  in trigonometric and exponential form.

To find its trigonometric representation we compute its modulus and argument:

$$x = \operatorname{Re} z_3 = -3, \quad y = \operatorname{Im} z_3 = 0, \\ |z_3| = \sqrt{x^2 + y^2} = \sqrt{(-3)^2 + 0^2} = 3, \quad \arg z_3 = \pi.$$

Thus, the trigonometric representation of the given complex number is

$$z_3 = -3 = 3(\cos \pi + i \sin \pi).$$

The exponential representation of the given complex number is then:  $z_3 = 3e^{\pi i}$ .

To find its trigonometric representation  $z_4 = -4i$ , we compute its modulus and argument:

$$x = \operatorname{Re} z_4 = 0, \quad y = \operatorname{Im} z_4 = -4,$$

$$|z_4| = \sqrt{x^2 + y^2} = \sqrt{0^2 + (-4)^2} = 4, \quad \arg z_4 = -\frac{\pi}{2}.$$

Thus, the trigonometric representation of the given complex number is

$$z_4 = -4i = 4 \left( \cos \left( -\frac{\pi}{2} \right) + i \sin \left( -\frac{\pi}{2} \right) \right).$$

The exponential representation of the given complex number is then:  $z_4 = 4e^{-\frac{\pi}{2}i}$ .

*Answer:*

$$z_1 = 1(\cos 0 + i \sin 0), \quad z_1 = e^{0i};$$

$$z_2 = 2 \left( \cos \frac{\pi}{2} + i \sin \frac{\pi}{2} \right), \quad z_2 = 2e^{\frac{\pi}{2}i};$$

$$z_3 = 3(\cos \pi + i \sin \pi), \quad z_3 = 3e^{\pi i};$$

$$z_4 = 4 \left( \cos \left( -\frac{\pi}{2} \right) + i \sin \left( -\frac{\pi}{2} \right) \right), \quad z_4 = 4e^{-\frac{\pi}{2}i}.$$

**Example 1.9.** Find the trigonometric and exponential representation of the complex number  $z = -1 - i\sqrt{3}$ .

*Solution:* the complex number  $z = -1 - i\sqrt{3}$  is in its algebraic representation. To find its trigonometric representation we compute its modulus and argument:  $x = \operatorname{Re} z = -1$ ,  $y = \operatorname{Im} z = -\sqrt{3}$ ,

$$|z| = \sqrt{x^2 + y^2} = \sqrt{(-1)^2 + (-\sqrt{3})^2} = 2,$$

$$\varphi = \arg z = -\pi + \arctg \sqrt{3} = -\pi + \frac{\pi}{3} = -\frac{2\pi}{3}.$$

Thus, the trigonometric representation of the given complex number is

$$z = -1 - i\sqrt{3} = 2 \left( \cos\left(-\frac{2\pi}{3}\right) + i \sin\left(-\frac{2\pi}{3}\right) \right).$$

The exponential representation of the given complex number  $z$  is then:

$$z = 2e^{-\frac{2\pi}{3}i}.$$

*Answer:*  $z = 2 \left( \cos\left(-\frac{2\pi}{3}\right) + i \sin\left(-\frac{2\pi}{3}\right) \right), z = 2e^{-\frac{2\pi}{3}i}.$

**Example 1.10.** Compute the modulus and argument of the complex number

$$z = -\sin\frac{\pi}{10} - i\cos\frac{\pi}{10}.$$

*Solution:* for the complex number  $z = -\sin\frac{\pi}{10} - i\cos\frac{\pi}{10}$  we have:

$$x = \operatorname{Re} z = -\sin\frac{\pi}{10} < 0, \quad y = \operatorname{Im} z = -\cos\frac{\pi}{10} < 0, \quad \text{thus,}$$

$$\begin{aligned} \arg z &= -\pi + \operatorname{arctg}\left(\frac{\cos\frac{\pi}{10}}{\sin\frac{\pi}{10}}\right) = -\pi + \operatorname{actg}\left(\operatorname{ctg}\frac{\pi}{10}\right) = -\pi + \operatorname{arctg}\left(\operatorname{tg}\left(\frac{\pi}{2} - \frac{\pi}{10}\right)\right) = \\ &= -\pi + \operatorname{arctg}\left(\operatorname{tg}\frac{2\pi}{5}\right) = -\pi + \frac{2\pi}{5} = -\frac{3}{5}\pi. \end{aligned}$$

$$\operatorname{Arg} z = \arg z + 2k\pi, \quad k = 0, \pm 1, \pm 2, \pm 3, \dots, \text{ thus,}$$

$$\operatorname{Arg} z = -\frac{3}{5}\pi + 2k\pi, \quad k = 0, \pm 1, \pm 2, \pm 3, \dots;$$

$$|z| = \sqrt{x^2 + y^2} = \sqrt{\sin^2\frac{\pi}{10} + \cos^2\frac{\pi}{10}} = 1.$$

*Answer:*  $\operatorname{Arg} z = -\frac{3}{5}\pi + 2k\pi, \quad k = 0, \pm 1, \pm 2, \pm 3, \dots, |z| = 1.$

## QUESTIONS FOR SELF-CONTROL:

1. What are Complex Numbers in Math?
2. Is it possible for a complex number to be also a real number?
3. What are Complex Numbers Used for?
4. What is Modulus in Complex Numbers?
5. What is Argument in Complex Numbers?
6. How to Graph Complex Numbers?
7. Explain the geometrical interpretation of the values:  $|\operatorname{Re}z|$ ,  $|\operatorname{Im}z|$ ,  $|z|$ ?
8. Are there complex numbers  $z$  such that  $z = \operatorname{Re} z$ ?
9. Are there complex numbers  $z$  such that  $z = \operatorname{Im} z$ ?
10. What is the relation between the numbers  $|z|$  and  $|\bar{z}|$ ,  $z \in \mathbb{C}$ ?
11. What is the argument of the complex number plotted as a point on the imaginary axis?
12. What is the argument of the complex number plotted as a point on the real axis?
13. Is it possible for two complex numbers with the same argument to be non-equal? What does it mean from the geometrical standpoint?
14. Is it possible for two complex numbers with the same modulus to be non-equal? What does it mean from the geometrical standpoint?
15. In which case two complex numbers are equal?

## TEST 1 “Complex numbers”

### Option 1

1. Compute the modulus of the complex number  $z = 1 - i$ .

A	B	C	D
$\sqrt{4}$	$\sqrt{2}$	0	$\sqrt{10}$

3. Which of the following values is a modulus of the complex number of  $z = 3 + 2i$ .

A	B	C	D
5	$\sqrt{13}$	1	$\sqrt{5}$

3. Which of the following values is an argument of  $z = 2 + 2i$ .

A	B	C	D
$\frac{\pi}{4}$	$\frac{5\pi}{4}$	$\frac{3\pi}{4}$	$\frac{7\pi}{4}$

4. Which of the following values is NOT an argument of  $z = 1 + \sqrt{3}i$ .

A	B	C	D
$\frac{\pi}{3}$	$\frac{5\pi}{3}$	$\frac{7\pi}{3}$	$-\frac{5\pi}{3}$

5. Find the real part of the complex number  $z = 1 - 2i$ .

A	B	C	D
2	3	1	-3

6. Find the imaginary part of the complex number  $z = 1 - 3i$ .

A	B	C	D
1	-3	-2	$3i$

7. What are the Cartesian coordinates of  $\bar{z}$ , if  $z = 1 - i$ .

A	B	C	D
(1,1)	(1,-1)	(-1,-1)	(-1,1)

8. Find the real part of the complex number  $z = 2e^{i\frac{\pi}{3}}$ .

A	B	C	D
1	$\sqrt{2}$	-1	$\sqrt{3}$

9. The exponential representation of the complex number  $z$  with

$$|z| = 8, \arg z = \frac{\pi}{3} \text{ is}$$

A	B	C	D
$8e^{i\frac{\pi}{4}}$	$8e^{\frac{\pi}{3}}$	$8e^{i\frac{\pi}{3}}$	$-8e^3$

10. The trigonometric representation of the complex number  $z = 3e^{2+i\frac{\pi}{4}}$  is

A	$3e^2 \left( \cos \frac{\pi}{4} + i \sin \frac{\pi}{4} \right)$	B	$2 \left( \cos \frac{\pi}{4} + i \sin \frac{\pi}{4} \right)$
C	$3 \left( \cos \left( 2 + \frac{\pi}{4} \right) + i \sin \left( 2 + \frac{3\pi}{4} \right) \right)$	D	$3e^2 \left( \cos \frac{\pi}{4} - i \sin \frac{\pi}{4} \right)$

**ANSWERS TO TEST 1. Option 1:**

1-B; 2-B; 3-A; 4-B; 5-C; 6-B; 7-A; 8-A; 9-C; 10-A.

## TEST 1 “Complex numbers”

### Option 2

1. Compute the modulus of the complex number  $z = -2 + i$ .

A	B	C	D
$\sqrt{5}$	$\sqrt{2}$	-1	$\sqrt{3}$

2. Which of the following values is a modulus of the complex number of  $z = 5 - 3i$ .

A	B	C	D
2	$\sqrt{13}$	4	$\sqrt{34}$

3. Which of the following values is an argument of  $z = 3 + 3i$ .

A	B	C	D
$\frac{\pi}{4}$	$\frac{5\pi}{4}$	$\frac{3\pi}{4}$	$\frac{7\pi}{4}$

4. Which of the following values is NOT an argument of  $z = 1 - \sqrt{3}i$ .

A	B	C	D
$-\frac{\pi}{3}$	$\frac{5\pi}{3}$	$-\frac{7\pi}{3}$	$\frac{2\pi}{3}$

5. Find the real part of the complex number  $z = -7 + 2i$ .

A	B	C	D
2	7	-7	-3

6. Find the imaginary part of the complex number  $z = 3 - i$ .

A	B	C	D
-1	3	2	$-i$

7. What are the Cartesian coordinates of  $\bar{z}$ , if  $z = -1 + i$ .

A	B	C	D
(1,1)	(1,-1)	(-1,-1)	(-1,1)

8. Find the real part of the complex number  $z = 4e^{i\frac{\pi}{3}}$ .

A	B	C	D
-1	2	$\sqrt{3}$	4

9. The exponential representation of the complex number  $z$  with

$$|z| = 7, \arg z = \frac{\pi}{6} \text{ is}$$

A	B	C	D
$7e^{i\frac{\pi}{4}}$	$7e^{\frac{\pi}{6}}$	$7e^{i\frac{\pi}{6}}$	$-7e^{\frac{\pi}{6}}$

10. The trigonometric representation of the complex number  $z = 4e^{3+i\frac{\pi}{4}}$  is

A	$4e^3 \left( \cos \frac{\pi}{4} + i \sin \frac{\pi}{4} \right)$	B	$12 \left( \cos \frac{\pi}{4} + i \sin \frac{\pi}{4} \right)$
C	$4 \left( \cos \left( 3 + \frac{\pi}{4} \right) + i \sin \left( 3 + \frac{\pi}{4} \right) \right)$	D	$4e^3 \left( \cos \frac{\pi}{4} - i \sin \frac{\pi}{4} \right)$

**ANSWERS TO TEST 1. Option 2:**

1-A; 2-D; 3-A; 4-D; 5-C; 6-A; 7-C; 8-D; 9-C; 10-A.

### TASKS FOR INDIVIDUAL WORK:

1. Plot the given complex numbers as points in the complex plain:
  - 1.1.  $z = 1 + 2i$ ;
  - 1.2.  $z = 1 + i$ ;
  - 1.3.  $z = -3i$ ;
  - 1.4.  $z = -4 - 5i$ ;
  - 1.5.  $z = 2$ ;
  - 1.6.  $z = 2 - i$ .
2. Find the real and imaginary parts of the given complex numbers:
  - 2.1.  $z = i$ ;
  - 2.2.  $z = 1 - i$ ;
  - 2.3.  $z = 3 + 3i$ ;
  - 2.4.  $z = 1 + i\sqrt{3}$ ;
  - 2.5.  $z = -2$ ;
  - 2.6.  $z = 4$ ;
  - 2.7.  $z = -1 + i$ .
  - 2.8.  $z = -5i$ .
3. Find the complex conjugate for the given complex numbers:
  - 3.1.  $z = 2 + 7i$ ;
  - 3.2.  $z = 5i$ ;
  - 3.3.  $z = -3 + i$ ;
  - 3.4.  $z = 8 - 2i$ .
4. Find the modulus and argument of the given complex numbers, write down their trigonometric and exponential representations:
  - 4.1.  $z = i$ ;
  - 4.2.  $z = 1 - i$ ;
  - 4.3.  $z = 3 + 3i$ ;
  - 4.4.  $z = 1 + i\sqrt{3}$ ;
  - 4.5.  $z = -2$ ;
  - 4.6.  $z = -1 + i$ .

## 2. OPERATIONS WITH COMPLEX NUMBERS

**Definition 2.1.** The *sum* of two complex numbers  $z_1 = x_1 + iy_1$  and  $z_2 = x_2 + iy_2$  is a new complex number  $z = x + iy$ , where  $x = x_1 + x_2$ ,  $y = y_1 + y_2$ , i.e.  $z = x + iy = (x_1 + x_2) + i(y_1 + y_2)$ .

**Definition 2.2.** The *product* of two complex numbers  $z_1 = x_1 + iy_1$  and  $z_2 = x_2 + iy_2$  is the complex number  $z = x + iy = (x_1x_2 - y_1y_2) + i(x_1y_2 + y_1x_2)$ .

The formula in Definition 2.2 can be readily obtained by applying the rules of multiplication of algebraic polynomials:

$$\begin{aligned} z = z_1 \cdot z_2 &= (x_1 + iy_1)(x_2 + iy_2) = x_1x_2 + ix_1y_2 + ix_2y_1 + i^2y_1y_2 = \\ &= x_1x_2 - y_1y_2 + i(x_1y_2 + y_1x_2). \end{aligned}$$

In particular,

$$z \cdot \bar{z} = (x + iy) \cdot (x - iy) = x^2 + y^2 = |z|^2.$$

Thus, we can apply the same operations to the complex numbers in their algebraic representation as to the first-degree polynomials. We also need to take into account, that  $i^2 = -1$ ,  $i^3 = i \cdot i^2 = -i$ ,  $i^4 = i^2 \cdot i^2 = (-1)(-1) = 1$ . In general, for any integer  $n$ , the  $n$ -th degree of the imaginary unit  $i$  is given by the rule:

$$i^n = \begin{cases} 1, & \text{for } n = 4k, \\ -1, & \text{for } n = 4k + 2, \\ i, & \text{for } n = 4k + 1, \\ -i, & \text{for } n = 4k + 3. \end{cases}.$$

The operations of addition and multiplication of complex numbers satisfy the following properties:

1.  $z_1 + z_2 = z_2 + z_1$  (commutative property of addition);
2.  $(z_1 + z_2) + z_3 = z_1 + (z_2 + z_3)$  (associative property of addition);
3.  $z_1 \cdot z_2 = z_2 \cdot z_1$  (commutative property of multiplication);
4.  $(z_1 \cdot z_2) \cdot z_3 = z_1 \cdot (z_2 \cdot z_3)$  (associative property of multiplication);
5.  $(z_1 + z_2) \cdot z_3 = z_1 \cdot z_3 + z_2 \cdot z_3$  (distributive property).

Subtraction of complex numbers can be defined as an operation opposite to addition, in the same manner as it is introduced for real numbers:

$$z_1 - z_2 = x_1 + iy_1 + (-x_2 - iy_2) = x_1 - x_2 + i(y_1 - y_2).$$

By the definition of the modulus of a complex number, we arrive at the formula for computing the distance between two points  $z_1$  and  $z_2$  in the plane:

$$d(z_1, z_2) = |z_1 - z_2| = \sqrt{(x_1 - x_2)^2 + (y_1 - y_2)^2}.$$

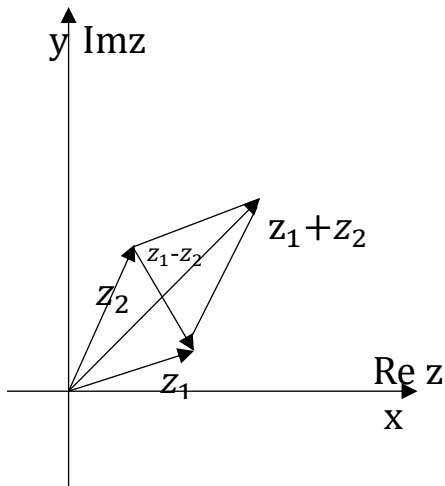


Fig 2.1.

From the geometrical standpoint addition and subtraction of two complex numbers can be seen as addition and subtraction of corresponding vectors (see Fig. 2.1).

Since the modulus of a complex number equals the length of corresponding vector, we arrive at the triangle inequality in the complex form:

$$|z_1 + z_2| \leq |z_1| + |z_2|.$$

By consequently applying the latter inequality  $n - 1$  times, we get the following generalization of the triangle inequality on the sum of  $n$  complex numbers:

$$|z_1 + z_2 + \dots + z_n| \leq |z_1| + |z_2| + \dots + |z_n|.$$

The vector representation of complex numbers also implies the property:

$$\left| |z_1| - |z_2| \right| \leq |z_1 - z_2|.$$

See Fig. 2.1.

**Definition 2.3.** The ratio of two complex numbers  $z_1 = x_1 + iy_1$  and  $z_2 = x_2 + iy_2$  is the complex number

$$z = \frac{z_1}{z_2} = \frac{z_1 \cdot \bar{z}_2}{z_2 \cdot \bar{z}_2} = \frac{z_1 \cdot \bar{z}_2}{|z_2|^2} = \frac{(x_1 + iy_1)(x_2 - iy_2)}{(x_2 + iy_2)(x_2 - iy_2)} = \frac{x_1x_2 + y_1y_2}{x_2^2 + y_2^2} + i \frac{y_1x_2 - x_1y_2}{x_2^2 + y_2^2}$$

**Example 2.1.** Compute the sum  $z_1 + z_2$ , difference  $z_1 - z_2$ , and product  $z_1 \cdot z_2$  of the complex numbers  $z_1 = 2 + 3i$  and  $z_2 = 1 - 5i$ .

*Solution:*

$$z_1 + z_2 = 2 + 3i + 1 - 5i = (2 + 1) + i(3 - 5) = 3 - 2i$$

$$z_1 - z_2 = 2 + 3i - (1 - 5i) = (2 - 1) + i(3 + 5) = 1 + 8i$$

By the rule of multiplication of algebraic polynomials, taking into account that  $i^2 = -1$ , we have:

$$z_1 \cdot z_2 = (2 + 3i) \cdot (1 - 5i) = 2 - 10i + 3i - 15i^2 = 17 - 7i.$$

*Answer:*  $z_1 + z_2 = 3 - 2i$ ,  $z_1 - z_2 = 1 + 8i$ ,  $z_1 \cdot z_2 = 17 - 7i$ .

**Example 2.2.** Compute the ratio of the complex numbers

$z_1 = 2 - 3i$  and  $z_2 = 5 + 2i$ .

*Solution:*

$$\frac{2 - 3i}{5 + 2i} = \frac{(2 - 3i)(5 - 2i)}{(5 + 2i)(5 - 2i)} = \frac{10 - 4i - 15i + 6i^2}{25 + 4} = \frac{4}{29} - \frac{19}{29}i.$$

*Answer:*  $\frac{2 - 3i}{5 + 2i} = \frac{4}{29} - \frac{19}{29}i$ .

**Example 2.3.** Compute the ratio of the complex number  $2 + i$  and the product  $(1 + i)(1 - 3i)$ .

*Solution:*

$$\begin{aligned}\frac{2+i}{(1+i)(1-3i)} &= \frac{2+i}{1-3i+i-3i^2} = \frac{2+i}{4-2i} = \frac{(2+i)(4+2i)}{(4-2i)(4+2i)} = \frac{6+8i}{20} = \\ &= \frac{3}{10} + \frac{4}{10}i.\end{aligned}$$

*Answer:*  $\frac{2+i}{(1+i)(1-3i)} = \frac{3}{10} + \frac{4}{10}i.$

**Example 2.4.** Prove that  $\overline{z_1 + z_2} = \bar{z}_1 + \bar{z}_2.$

*Solution:* using the algebraic representation of the complex numbers

$z_1 = x_1 + iy_1$  and  $z_2 = x_2 + iy_2$ , we can write

$$z_1 + z_2 = x_1 + iy_1 + x_2 + iy_2 = (x_1 + x_2) + i(y_1 + y_2),$$

hence, the complex conjugate of the number  $z_1 + z_2$  is the number

$$\overline{z_1 + z_2} = (x_1 + x_2) - i(y_1 + y_2) = x_1 - iy_1 + x_2 - iy_2 = \bar{z}_1 + \bar{z}_2. \blacksquare$$

Conjugates of the complex numbers satisfy the following properties:

- $\overline{\overline{z}} = z$
- $\overline{z_1 - z_2} = \bar{z}_1 - \bar{z}_2$
- $\overline{z_1 \cdot z_2} = \bar{z}_1 \cdot \bar{z}_2$
- $\overline{-z} = -\bar{z}$
- $\overline{\begin{pmatrix} z_1 \\ z_2 \end{pmatrix}} = \begin{pmatrix} \bar{z}_1 \\ \bar{z}_2 \end{pmatrix}$
- $\overline{\overline{z}} = z$
- $z + \bar{z} = 2 \operatorname{Re} z$
- $z - \bar{z} = 2i \operatorname{Im} z.$

**Example 2.5.** Find the real solution of the equation

$$(3+i)x + (7-2i)y = -10+i.$$

*Solution:* since we are looking for real  $x$  and  $y$ , we can separate the real and imaginary parts in the left-hand side of the equation as follows:

$$3x + 7y + i(x - 2y) = -10 + i.$$

Two complex numbers are equal if and only if they have equal real and imaginary parts. Hence, the previous equality implies the following system of algebraic equations:

$$\begin{cases} 3x + 7y = -10, \\ x - 2y = 1. \end{cases}$$

Solving this system with respect to the unknowns  $x$  and  $y$ , we get

$$x = -1, \quad y = -1.$$

*Answer:* the real solution of the equation  $(3+i)x + (7-2i)y = -10+i$  is

$$x = -1, \quad y = -1.$$

**Example 2.6.** Find the real solution of the equation

$$(4+2i)x + (5-3i)y - 23 - i = -10.$$

*Solution:* since we are looking for real  $x$  and  $y$ , we can separate the real and imaginary parts in the left-hand side of the equation as follows:

$$4x + 5y + i(2x - 3y) = 13 + i.$$

Two complex numbers are equal if and only if they have equal real and imaginary parts. Hence, the previous equality implies the following system of algebraic equations:

$$\begin{cases} 4x + 5y = 13, \\ 2x - 3y = 1. \end{cases}$$

Solving this system with respect to the unknowns  $x$  and  $y$ , we get

$$x = 2, \quad y = 1.$$

*Answer:* the real solution of the equation  $(4 + 2i)x + (5 - 3i)y - 23 - i = -10$  is  $x = 2, y = 1$ .

**Example 2.7.** Perform the operations with complex numbers:

(a)  $(5 + 2i) \cdot (1 - i)$ ;

(b)  $\frac{1 - 3i}{4 - i}$ ;

(c)  $z = \sqrt{3} - 7i, \bar{z} = \sqrt{3} + 7i, z - \bar{z} = ?, (z - \bar{z})^5 = ?$

*Solution:*

(a)  $(5 + 2i) \cdot (1 - i) = 5 - 5i + 2i - 2i^2 = 5 - 5i + 2i + 2 = 7 - 3i$ ;

(b)  $\frac{1 - 3i}{4 - i} = \frac{(1 - 3i)(4 + i)}{(4 - i)(4 + i)} = \frac{4 + i - 12i + 3}{16 + 1} = \frac{7 - 11i}{17}$ ;

(c)  $z - \bar{z} = \sqrt{3} - 7i - (\sqrt{3} + 7i) = \sqrt{3} - 7i - \sqrt{3} - 7i = -14i$ ;

$(z - \bar{z})^5 = (\sqrt{3} - 7i - \sqrt{3} - 7i)^5 = (-14i)^5 = -(14)^5 i^5 = -38416i$ .

*Answer:* (a)  $(5 + 2i) \cdot (1 - i) = 7 - 3i$ ; (b)  $\frac{1 - 3i}{4 - i} = \frac{7 - 11i}{17}$ ;

(c)  $z = \sqrt{3} - 7i, \bar{z} = \sqrt{3} + 7i, z - \bar{z} = -14i, (z - \bar{z})^5 = -38416i$ .

**Example 2.8.** Simplify the expressions:

(a)  $\frac{1 - i}{1 + i}$ ;

(b)  $\frac{1}{i} \cdot \frac{1 + i}{1 - i}$ ;

(c)  $(-1 - i)(-1 + i)(1 + i)(1 - i)$

*Solution:*

(a)  $\frac{1 - i}{1 + i} = \frac{1 - i}{1 + i} \cdot \frac{1 - i}{1 - i} = \frac{1 - 2i - 1}{1 + 1} = \frac{-2i}{2} = -i$ ;

(b)  $\frac{1}{i} \cdot \frac{1 + i}{1 - i} = \frac{i}{i^2} \cdot \frac{(1 + i)(1 + i)}{(1 - i)(1 + i)} = \frac{i(1 + i)^2}{-1(1 + 1)} = \frac{i(1 + 2i - 1)}{-2} = \frac{2i^2}{-2} = 1$ ;

$$(c) (-1-i)(-1+i)(1+i)(1-i) = \left((-1)^2 - i^2\right)(1^2 - i^2) = 2 \cdot 2 = 4.$$

$$\text{Answer: (a) } \frac{1-i}{1+i} = -i; \text{(b) } \frac{1}{i} \cdot \frac{1+i}{1-i} = 1; \text{(c) } (-1-i)(-1+i)(1+i)(1-i) = 4.$$

**Example 2.9.** Solve the equation  $x^2 - 2\sqrt{3}x + 4 = 0$ .

*Solution:* compute the discriminant

$$D = (2\sqrt{3})^2 - 4 \cdot 4 = 4 \cdot 3 - 16 = 12 - 16 = -4 = 4 \cdot (-1)$$

$$\text{Since } i^2 = -1, \sqrt{D} = \sqrt{-4} = \pm 2i, x_{1,2} = \frac{2\sqrt{3} \pm 2i}{2} = \sqrt{3} \pm i.$$

$$\text{Answer: } x_1 = \sqrt{3} + i, x_2 = \sqrt{3} - i.$$

**Example 2.10.** Write down the quadratic equation that has the given solutions (make use of Vieta's theorem):

$$(a) x_1 = 1 + i\sqrt{3}, x_2 = 1 - i\sqrt{3};$$

$$(b) x_1 = 2 + 3i, x_2 = 2i.$$

*Solution:* we shall be looking for the quadratic equation in the form

$$x^2 + px + q = 0. \text{ Then, by Vieta's theorem } \begin{cases} x_1 + x_2 = -p, \\ x_1 \cdot x_2 = q, \end{cases}$$

$$(a) x_1 + x_2 = 1 + i\sqrt{3} + 1 - i\sqrt{3} = 2 = -p, \text{ which means } p = -2,$$

$$x_1 \cdot x_2 = (1 + i\sqrt{3}) \cdot (1 - i\sqrt{3}) = 1 + 3 = 4 = q.$$

Hence, the required quadratic equation is  $x^2 - 2x + 4 = 0$ .

$$(b) x_1 + x_2 = 2 + 3i + 2i = 2 + 5i = -p, p = -(2 + 5i),$$

$$x_1 \cdot x_2 = (2 + 3i) \cdot (2i) = 4i + 6i^2 = -6 + 4i = q.$$

Hence, the required quadratic equation is  $x^2 - (2 + 5i)x - 6 + 4i = 0$ .

$$\text{Answer: (a) } x^2 - 2x + 4 = 0; \text{(b) } x^2 - (2 + 5i)x - 6 + 4i = 0.$$

**Remark:** If the solutions of a quadratic equation are complex conjugated, then

the coefficients of the equation should be real. The inverse is also true: a quadratic equation with real coefficients and negative discriminant has complex conjugated solutions.

**Example 2.11.** Write down a quadratic equation given its coefficients are real and one of its solutions is  $(3 - i)(2i - 4)$ .

*Solution:* denote

$$x_1 = (3 - i)(2i - 4) = 6i - 12 - 2i^2 + 4i = 10i - 12 + 2 = -10 + 10i.$$

Since the quadratic equation is known to have real coefficients, its solutions are complex conjugated. Hence, we can find the second solution of the equation:  $x_2 = \bar{x}_1 = -10 - 10i$ .

Arguing as in Example 2.8, we compute the coefficients of the equation:

$$-p = x_1 + x_2 = -10 + 10i - 10 - 10i = -20, \quad \text{hence, } p = 20;$$

$$q = x_1 \cdot x_2 = (-10 + 10i) \cdot (-10 - 10i) = 200.$$

Thus, the required equation is  $x^2 + 20x + 200 = 0$ .

*Answer:*  $x^2 + 20x + 200 = 0$ .

**Example 2.12.** Prove the equality:

$$\frac{6 - i}{3 + 4i} = \frac{13 + 41i}{-25 + 25i}.$$

*Solution:* compute the ratios in the left- and right-hand sides of the equality:

$$\frac{6 - i}{3 + 4i} = \frac{(6 - i)(3 - 4i)}{(3 + 4i)(3 - 4i)} = \frac{18 - 24i - 3i + 4i^2}{9 + 16} = \frac{14 - 27i}{25} = \frac{14}{25} - \frac{27}{25}i$$

$$\frac{13 + 41i}{-25 + 25i} = \frac{(13 + 41i)(-25 - 25i)}{(-25 + 25i)(-25 - 25i)} = \frac{-325 - 325i - 1025i + 1025}{625 + 625} = \frac{700}{1250} - \frac{1350}{1250}i =$$

$$\frac{14 \cdot 50}{25 \cdot 50} - \frac{27 \cdot 50}{25 \cdot 50}i = \frac{14}{25} - \frac{27}{25}i.$$

Hence,  $\frac{6 - i}{3 + 4i} = \frac{13 + 41i}{-25 + 25i}$ . ■

Let us study the operations of multiplication and division of complex numbers given in either trigonometric or exponential form.

For the trigonometric representations of complex numbers  $z_1 = |z_1|(\cos \varphi_1 + i \sin \varphi_1)$  and  $z_2 = |z_2|(\cos \varphi_2 + i \sin \varphi_2)$  we have:

$$\begin{aligned} z_1 \cdot z_2 &= |z_1| |z_2| (\cos \varphi_1 + i \sin \varphi_1) (\cos \varphi_2 + i \sin \varphi_2) = \\ &= |z_1| |z_2| (\cos \varphi_1 \cos \varphi_2 - \sin \varphi_1 \sin \varphi_2) + i (\sin \varphi_1 \cos \varphi_2 + \cos \varphi_1 \sin \varphi_2) = \\ &= |z_1| |z_2| (\cos(\varphi_1 + \varphi_2) + i \sin(\varphi_1 + \varphi_2)). \end{aligned}$$

Thus, *when multiplying two complex numbers written in the trigonometric form we need to multiply their modules and add their arguments:*

$$|z_1 z_2| = |z_1| |z_2|, \arg(z_1 z_2) = \arg(z_1) + \arg(z_2).$$

For the complex numbers given in the *exponential form* the same rule applies:

$$z_1 z_2 = |z_1| e^{i\varphi_1} |z_2| e^{i\varphi_2} = |z_1| |z_2| e^{i(\varphi_1 + \varphi_2)}.$$

Similarly, we can compute the ratio of two complex numbers:

$$\begin{aligned} \frac{z_1}{z_2} &= \frac{|z_1|(\cos \varphi_1 + i \sin \varphi_1)}{|z_2|(\cos \varphi_2 + i \sin \varphi_2)} = \frac{|z_1|(\cos \varphi_1 + i \sin \varphi_1)(\cos \varphi_2 - i \sin \varphi_2)}{|z_2|(\cos \varphi_2 + i \sin \varphi_2)(\cos \varphi_2 - i \sin \varphi_2)} = \\ &= \frac{|z_1|(\cos \varphi_1 \cos \varphi_2 + \sin \varphi_1 \sin \varphi_2) + i(\sin \varphi_1 \cos \varphi_2 - \cos \varphi_1 \sin \varphi_2)}{|z_2|(\cos^2 \varphi_2 + \sin^2 \varphi_2)} = \\ &= \frac{|z_1|}{|z_2|} (\cos(\varphi_1 - \varphi_2) + i \sin(\varphi_1 - \varphi_2)). \end{aligned}$$

Hence, *when dividing two complex numbers written in the trigonometric form we divide their modules and subtract their arguments:*

$$\left| \frac{z_1}{z_2} \right| = \frac{|z_1|}{|z_2|}, \arg\left(\frac{z_1}{z_2}\right) = \arg(z_1) - \arg(z_2).$$

For the complex numbers given in the *exponential form* we have:

$$\frac{z_1}{z_2} = \frac{|z_1| e^{i\varphi_1}}{|z_2| e^{i\varphi_2}} = \frac{|z_1|}{|z_2|} e^{i(\varphi_1 - \varphi_2)}.$$

**Definition 2.4.** The  $n$ -th degree of a number  $z$  is defined as  $n$ -times consecutive multiplication of  $z$  by itself:  $z^n = \underbrace{z \cdot z \cdot z \cdot \dots \cdot z}_n$ .

For any two complex numbers  $z_1$  and  $z_2$  the following algebraic identities can be given

$$(z_1 + z_2)^2 = (z_1)^2 + (z_2)^2 + 2 z_1 z_2$$

$$(z_1 - z_2)^2 = (z_1)^2 + (z_2)^2 - 2 z_1 z_2$$

$$(z_1)^2 - (z_2)^2 = (z_1 + z_2)(z_1 - z_2)$$

$$(z_1 + z_2)^3 = (z_1)^3 + 3(z_1)^2 z_2 + 3(z_2)^2 z_1 + (z_2)^3$$

$$(z_1 - z_2)^3 = (z_1)^3 - 3(z_1)^2 z_2 + 3(z_2)^2 z_1 - (z_2)^3$$

Using the rules of multiplication of complex numbers written in the trigonometric or exponential forms we can formulate the **Moivre's formula** as follows:

**Moivre's formula** is used for computing the  $n$ -th degree of a complex number given in either trigonometric or exponential form:

$$z^n = |z|^n (\cos n\varphi + i \sin n\varphi), \text{ or } z^n = |z|^n e^{in\varphi}, n \in \mathbb{N}.$$

**Example 2.13.** Compute  $(-1 + i\sqrt{3})^5$ .

*Solution:* first we find the trigonometric representation of the number

$$z = -1 + i\sqrt{3}:$$

$$|z| = \sqrt{1+3} = 2,$$

$$\arg z = \pi - \arctg \sqrt{3} = \pi - \frac{\pi}{3} = \frac{2\pi}{3},$$

$$z = 2 \left( \cos \frac{2\pi}{3} + i \sin \frac{2\pi}{3} \right).$$

Then, by Moivre's formula we get:

$$(-1+i\sqrt{3})^5 = 2^5 \left( \cos \frac{10\pi}{3} + i \sin \frac{10\pi}{3} \right).$$

Applying the reduction formulae of trigonometric functions, we can write:

$$\begin{aligned} \cos \frac{10\pi}{3} &= \cos \left( 3\pi + \frac{\pi}{3} \right) = -\cos \frac{\pi}{3} = -\frac{1}{2}, \\ \sin \frac{10\pi}{3} &= \sin \left( 3\pi + \frac{\pi}{3} \right) = -\sin \frac{\pi}{3} = -\frac{\sqrt{3}}{2}. \end{aligned}$$

Hence,

$$(-1+i\sqrt{3})^5 = 2^5 \left( \cos \frac{10\pi}{3} + i \sin \frac{10\pi}{3} \right) = 32 \left( -\frac{1}{2} - i \frac{\sqrt{3}}{2} \right) = 16(-1-i\sqrt{3}).$$

*Answer:*  $(-1+i\sqrt{3})^5 = -16-16\sqrt{3}i.$

**Example 2.14.** Compute  $\left( \frac{1+i\sqrt{3}}{1-i} \right)^{40}$ .

*Solution:* first we find the trigonometric representation of the number  $z_1 = 1+i\sqrt{3}$ :

$$|z_1| = \sqrt{1+3} = 2, \quad \arg z_1 = \arctg \sqrt{3} = \frac{\pi}{3}.$$

Then, find the trigonometric representation of the number  $z_2 = 1-i$ :

$$|z_2| = \sqrt{1+1} = \sqrt{2}, \quad \arg z_2 = \arctg(-1) = -\frac{\pi}{4}.$$

$$\left| \frac{1+i\sqrt{3}}{1-i} \right| = \frac{|1+i\sqrt{3}|}{|1-i|} = \frac{2}{\sqrt{2}} = \sqrt{2},$$

$$\arg \left( \frac{1+i\sqrt{3}}{1-i} \right) = \arg(1+i\sqrt{3}) - \arg(1-i) = \frac{\pi}{3} - \left( -\frac{\pi}{4} \right) = \frac{4\pi + 3\pi}{12} = \frac{7\pi}{12}$$

Then, by Moivre's formula we get:

$$\begin{aligned} \left| \frac{1+i\sqrt{3}}{1-i} \right|^{40} &= (\sqrt{2})^{40} = 2^{20} \\ \arg \left( \frac{1+i\sqrt{3}}{1-i} \right)^{40} &= 40 \cdot \arg \left( \frac{1+i\sqrt{3}}{1-i} \right) = 40 \cdot \frac{7\pi}{12} = \frac{70\pi}{3} \end{aligned}$$

$$\left(\frac{1+i\sqrt{3}}{1-i}\right)^{40} = 2^{20} \left(\cos \frac{70\pi}{3} + i \sin \frac{70\pi}{3}\right).$$

Applying the reduction formulae of trigonometric functions, we can write:

$$\cos \frac{70\pi}{3} = \cos \left(24\pi - \frac{2\pi}{3}\right) = \cos \frac{2\pi}{3} = -\frac{1}{2},$$

$$\sin \frac{70\pi}{3} = \sin \left(24\pi - \frac{2\pi}{3}\right) = -\sin \frac{2\pi}{3} = -\frac{\sqrt{3}}{2}.$$

Hence,

$$\left(\frac{1+i\sqrt{3}}{1-i}\right)^{40} = 2^{20} \left(\cos \frac{70\pi}{3} + i \sin \frac{70\pi}{3}\right) = 2^{20} \left(-\frac{1}{2} - i \frac{\sqrt{3}}{2}\right) = -2^{19} (1+i\sqrt{3}).$$

$$\text{Answer: } \left(\frac{1+i\sqrt{3}}{1-i}\right)^{40} = -2^{19} (1+i\sqrt{3}).$$

**Definition 2.5.** The *root* of a complex number  $z \neq 0$  of degree  $n$  ( $n \in \mathbb{N}$ ,  $n \geq 2$ ),  $\sqrt[n]{z}$  is the complex number  $w$  such that  $w^n = z$ .

**Theorem.** Let  $w^n = z$ ,  $z \neq 0$ . Then,

$$\sqrt[n]{z} = \sqrt[n]{|z|} \left(\cos \frac{\varphi + 2k\pi}{n} + i \sin \frac{\varphi + 2k\pi}{n}\right), \quad k = 0, 1, 2, \dots, n-1, \quad \varphi = \arg z.$$

*Proof.* Let us write down the trigonometric representation of the complex numbers  $w$  and  $z$ :

$$w = |w|(\cos \theta + i \sin \theta), \quad z = |z|(\cos \varphi + i \sin \varphi)$$

By Moivre's formula  $w^n = |w|^n (\cos n\theta + i \sin n\theta)$ .

Since  $w^n = z$ , by Definition 1.8. we have

$$|z| = |w|^n, \quad \varphi + 2k\pi = n\theta.$$

Thus,

$$|w| = \sqrt[n]{|z|}, \quad \theta = \frac{\varphi + 2k\pi}{n}.$$

And we arrive at the required formula:

$$w = \sqrt[n]{|z|} \left( \cos \frac{\varphi + 2k\pi}{n} + i \sin \frac{\varphi + 2k\pi}{n} \right), \text{ where } k = 0, 1, 2, \dots, n-1. \blacksquare$$

The  $n$ -th root of a complex number has  $n$  complex values with the same modulus but different arguments. The arguments of two values of the root differ by a multiple of  $\frac{2\pi}{n}$ . Indeed,

$$\frac{\varphi + 2\pi(k+1)}{n} - \frac{\varphi + 2k\pi}{n} = \frac{2\pi}{n}.$$

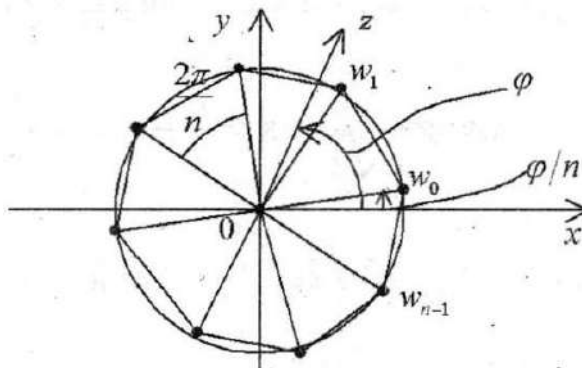


Fig. 2.2.

Thus, the values of the root of degree  $n$  of a complex number  $z$  can be plotted in the complex plane by  $n$  points situated at an equal angular distance  $\frac{2\pi}{n}$  on a circle of radius  $\sqrt[n]{|z|}$ , i.e. at the vertices of a regular  $n$ -sided polygon inscribed in a circle of radius  $\sqrt[n]{|z|}$  (see Fig. 2.2).

**Example 2.15.** Find all complex solutions of the equation  $w^4 = 1$  and plot them in the complex plane.

*Solution:* the equation  $w^4 = 1$  has four complex solutions. Let us factorize the difference:

$$w^4 - 1 = (w^2 - 1)(w^2 + 1) = (w - 1)(w + 1)(w - i)(w + i) = 0,$$

$$w_1 = 1, w_2 = -1, w_3 = i, w_4 = -i.$$

The same values can be obtained by applying the formula for computing the root of the fourth degree of number 1:  $w = \sqrt[4]{1}$ .

The trigonometric representation of the number  $z = 1$  is

$$z = 1(\cos 0 + i \sin 0).$$

Thus,  $|z| = 1$ ,  $\varphi = 0$ ,  $n = 4$ ,  $k = 0, 1, 2, 3$ .

$$k = 0, w_0 = \sqrt[4]{|1|} \left( \cos \frac{0}{4} + i \sin \frac{0}{4} \right) = 1,$$

$$k = 1, w_1 = \sqrt[4]{|1|} \left( \cos \frac{0 + 2\pi}{4} + i \sin \frac{0 + 2\pi}{4} \right) = \left( \cos \frac{\pi}{2} + i \sin \frac{\pi}{2} \right) = i,$$

$$k = 2, w_2 = \sqrt[4]{|1|} \left( \cos \frac{0 + 4\pi}{4} + i \sin \frac{0 + 4\pi}{4} \right) = (\cos \pi + i \sin \pi) = -1,$$

$$k = 3, w_3 = \sqrt[4]{|1|} \left( \cos \frac{0 + 6\pi}{4} + i \sin \frac{0 + 6\pi}{4} \right) = \left( \cos \frac{3\pi}{2} + i \sin \frac{3\pi}{2} \right) = -i.$$

*Answer:*  $w_0 = 1$ ,  $w_1 = i$ ,  $w_2 = -1$ ,  $w_3 = -i$ . The values of the root are plotted in the vertices of a square inscribed in a circle of radius 1 (see Fig. 2.3).

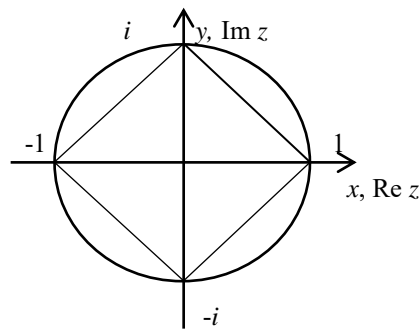


Fig. 2.3

**Example 2.16.** Compute  $(-1 + i)^{\frac{1}{3}}$ .

*Solution:* we note, that taking a number to the power  $1/3$  is the same as computing the root of degree 3 of this number.

First we write the given number in the exponential form:

$$|-1+i| = \sqrt{2}, \quad \arg(-1+i) = \frac{3\pi}{4}, \quad -1+i = 2^{\frac{1}{2}} e^{\frac{3i\pi}{4}}.$$

Then,

$$(-1+i)^{\frac{1}{3}} = 2^{\frac{1}{6}} e^{\frac{i\pi}{4} + \frac{2i\pi k}{3}}, \quad k = 0, 1, 2.$$

For different values of  $k$  we have:

$$k = 0, \quad z_0 = 2^{\frac{1}{6}} e^{\frac{i\pi}{4}};$$

$$k = 1, \quad z_1 = 2^{\frac{1}{6}} e^{\frac{11i\pi}{12}};$$

$$k = 2, \quad z_2 = 2^{\frac{1}{6}} e^{\frac{19i\pi}{12}}.$$

Answer:  $z_0 = 2^{\frac{1}{6}} e^{\frac{i\pi}{4}}$ ,  $z_1 = 2^{\frac{1}{6}} e^{\frac{11i\pi}{12}}$ ,  $z_2 = 2^{\frac{1}{6}} e^{\frac{19i\pi}{12}}$  (see Fig. 2.4).

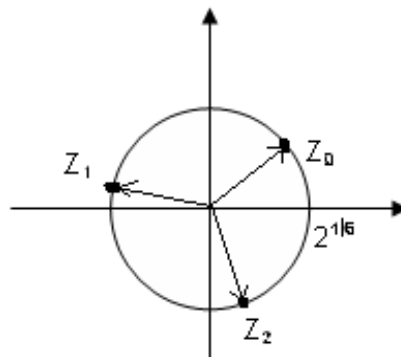


Fig. 2.4.

**Example 2.17.** Find all values  $\sqrt[4]{1-i}$ .

*Solution:* The trigonometric representation of the number  $z = \sqrt[4]{1-i}$  is

$$z = \sqrt[4]{2} \left( \cos\left(-\frac{\pi}{4}\right) + i \sin\left(-\frac{\pi}{4}\right) \right).$$

Thus,  $|z| = \sqrt[4]{2}$ ,  $\varphi = -\frac{\pi}{4}$ ,  $n = 4$ ,  $k = 0, 1, 2, 3$ .

$$w_k = \sqrt[8]{2} \left( \cos \frac{-\frac{\pi}{4} + 2k\pi}{4} + i \sin \frac{-\frac{\pi}{4} + 2k\pi}{4} \right),$$

$$k=0 \quad w_0 = \sqrt[8]{2} \left( \cos \frac{-\frac{\pi}{4}}{4} + i \sin \frac{-\frac{\pi}{4}}{4} \right) = \sqrt[8]{2} \left( \cos \frac{\pi}{16} - i \sin \frac{\pi}{16} \right),$$

$$k=1 \quad w_1 = \sqrt[8]{2} \left( \cos \frac{-\frac{\pi}{4} + 2\pi}{4} + i \sin \frac{-\frac{\pi}{4} + 2\pi}{4} \right) = \sqrt[8]{2} \left( \cos \frac{7\pi}{16} + i \sin \frac{7\pi}{16} \right),$$

$$k=2, \quad w_2 = \sqrt[8]{2} \left( \cos \frac{-\frac{\pi}{4} + 4\pi}{4} + i \sin \frac{-\frac{\pi}{4} + 4\pi}{4} \right) = \sqrt[8]{2} \left( \cos \frac{15\pi}{16} - i \sin \frac{15\pi}{16} \right),$$

$$k=3, \quad w_3 = \sqrt[8]{2} \left( \cos \frac{-\frac{\pi}{4} + 6\pi}{4} + i \sin \frac{-\frac{\pi}{4} + 6\pi}{4} \right) = \sqrt[8]{2} \left( \cos \frac{23\pi}{16} - i \sin \frac{23\pi}{16} \right).$$

*Answer:*  $w_0 = \sqrt[8]{2} \left( \cos \frac{\pi}{16} - i \sin \frac{\pi}{16} \right), \quad w_1 = \sqrt[8]{2} \left( \cos \frac{7\pi}{16} + i \sin \frac{7\pi}{16} \right),$

$$w_2 = \sqrt[8]{2} \left( \cos \frac{15\pi}{16} - i \sin \frac{15\pi}{16} \right), \quad w_3 = \sqrt[8]{2} \left( \cos \frac{23\pi}{16} - i \sin \frac{23\pi}{16} \right).$$

**Example 2.18.** Find all values  $\sqrt{1+i\sqrt{3}}$ .

*Solution:* The trigonometric representation of the number  $z = 1+i\sqrt{3}$  is

$$z = 2 \left( \cos \frac{\pi}{3} + i \sin \frac{\pi}{3} \right).$$

Thus,  $|z| = 2$ ,  $\varphi = \frac{\pi}{3}$ ,  $n = 2$ ,  $k = 0, 1$ .

$$w_k = \sqrt{2} \left( \cos \frac{\frac{\pi}{3} + 2k\pi}{2} + i \sin \frac{\frac{\pi}{3} + 2k\pi}{2} \right),$$

$$k=0 \quad w_0 = \sqrt{2} \left( \cos \frac{\frac{\pi}{3}}{2} + i \sin \frac{\frac{\pi}{3}}{2} \right) = \sqrt{2} \left( \cos \frac{\pi}{6} + i \sin \frac{\pi}{6} \right) = \sqrt{2} \left( \frac{\sqrt{3}}{2} + i \frac{1}{2} \right) =$$

$$= \frac{\sqrt{2}}{2} (\sqrt{3} + i),$$

$$k=1 \quad w_1 = \sqrt{2} \left( \cos \frac{\frac{\pi}{3} + 2\pi}{2} + i \sin \frac{\frac{\pi}{3} + 2\pi}{2} \right) = \sqrt{2} \left( \cos \frac{7\pi}{6} + i \sin \frac{7\pi}{6} \right) =$$

$$= \sqrt{2} \left( -\frac{\sqrt{3}}{2} - \frac{1}{2}i \right) = -\frac{\sqrt{2}}{2} (\sqrt{3} + i).$$

$$\text{Answer: } w_0 = \frac{\sqrt{2}}{2} (\sqrt{3} + i), \quad w_1 = -\frac{\sqrt{2}}{2} (\sqrt{3} + i).$$

**Example 2.19.** Compute  $z = \sqrt{7 - 24i}$ .

*Solution:* Getting a root from a complex number  $\sqrt{7 - 24i}$ , we do not need to use the trigonometric form of the complex number as it is an unreasonable way. Let's use another method. We take into account that

$$7 - 24i = 16 - 9 - 24i = 4^2 + (3i)^2 - 2 \cdot 4 \cdot 3i = (4 - 3i)^2$$

$$\text{Then, } z = \sqrt{7 - 24i} = \sqrt{(4 - 3i)^2} = \pm(4 - 3i).$$

$$\text{Answer: } w_0 = 4 - 3i, \quad w_1 = -4 + 3i.$$

**Remark:** If you could not complete a square under the root, then you can calculate  $\sqrt{7 - 24i}$  according to the definition, i.e.  $\sqrt{7 - 24i} = x + iy$ , where  $x, y$  are real

numbers. To find them, we have to square both parts of the equality and equate the real and imaginary parts of the complex numbers:

$$7 - 24i = (x + iy)^2 = x^2 + 2xyi - y^2 \Rightarrow \begin{cases} x^2 - y^2 = 7, \\ xy = -12. \end{cases}$$

Further, the following system of two equations should be solved:

$$\begin{cases} x^2 - y^2 = 7, \\ xy = -12. \end{cases} \Rightarrow y = \frac{-12}{x}, \quad x^2 - \frac{144}{x^2} = 7 \Rightarrow x^4 - 7x^2 - 144 = 0. \\ \Rightarrow \begin{cases} x_1 = 4, & \begin{cases} y_1 = -3, \\ y_2 = 3. \end{cases} \\ x_2 = -4, \end{cases}$$

Therefore, the number  $\sqrt{7 - 24i}$  has the two values:  $4 - 3i$  and  $-4 + 3i$ .

**Example 2.20.** Solve the equation  $z^2 - (2 + i)z + 7i - 1 = 0$ .

*Solution:* We use the formula for calculating the roots of a quadratic equation and the result of the previous example:

$$\begin{aligned} z_{1,2} &= \frac{2 + i \pm \sqrt{(2 + i)^2 - 28i + 4}}{2} = \frac{2 + i \pm \sqrt{7 - 24i}}{2} = \\ &= \frac{2 + i \pm \sqrt{(4 - 3i)^2}}{2} = \frac{2 + i \pm (4 - 3i)}{2} \\ \Rightarrow z_1 &= \frac{2 + i + 4 - 3i}{2} = 3 - i, \quad z_2 = \frac{2 + i - (4 - 3i)}{2} = -1 + 2i. \end{aligned}$$

*Answer:*  $z_1 = 3 - i$ ,  $z_2 = -1 + 2i$ .

**Example 2.21.** Find the trigonometric and exponential representation of the complex number  $z = \frac{(1 + i^{35})^2}{(1 - i)^3}$ .

$$\text{plex number } z = \frac{(1 + i^{35})^2}{(1 - i)^3}.$$

*Solution:* To find its trigonometric representation we compute its modulus and argument. Note that  $i^4 = i^2 \cdot i^2 = (-1)(-1) = 1$ . Then

$$i^{35} = i^{32} \cdot i^3 = (i^4)^8 \cdot i^3 = [i^2 = -1] = -i.$$

Therefore,  $1+i^{35} = 1-i$ , so

$$z = \frac{(1+i^{35})^2}{(1-i)^3} = \frac{(1-i)^2}{(1-i)^3} = \frac{1}{1-i} = \frac{1}{1-i} \cdot \frac{1+i}{1+i} = \frac{1+i}{2} = \frac{1}{2} + \frac{1}{2}i,$$

$$x = \operatorname{Re} z = \frac{1}{2}, \quad y = \operatorname{Im} z = \frac{1}{2},$$

$$|z| = \sqrt{x^2 + y^2} = \sqrt{\left(\frac{1}{2}\right)^2 + \left(\frac{1}{2}\right)^2} = \sqrt{\frac{1}{4} + \frac{1}{4}} = \sqrt{\frac{2}{4}} = \frac{1}{\sqrt{2}},$$

$$\varphi = \arg z = \operatorname{arctg} 1 = \frac{\pi}{4}.$$

Thus, the trigonometric representation of the given complex number is

$$z = \frac{1}{\sqrt{2}} \left( \cos \frac{\pi}{4} + i \cdot \sin \frac{\pi}{4} \right).$$

The exponential representation of the given complex number  $z$  is, then,

$$z = \frac{1}{\sqrt{2}} e^{\frac{\pi i}{4}}.$$

*Answer:*  $z = \frac{1}{\sqrt{2}} \left( \cos \frac{\pi}{4} + i \cdot \sin \frac{\pi}{4} \right), \quad z = \frac{1}{\sqrt{2}} e^{\frac{\pi i}{4}}.$

**Example 2.22.** Solve the system of equations

$$\begin{cases} (3-i)z_1 + (4+2i)z_2 = 1+3i, \\ (4+2i)z_1 - (2+3i)z_2 = 7. \end{cases}$$

*Solution:* According to the Kramer method:

$$\begin{aligned} \Delta &= \begin{vmatrix} 3-i & 4+2i \\ 4+2i & -2-3i \end{vmatrix} = (3-i)(-2-3i) - (4+2i)^2 = \\ &= -6 - 9i + 2i - 3 - (16 + 16i - 4) = -9 - 7i - 12 - 16i = -21 - 23i, \end{aligned}$$

$$\begin{aligned} \Delta_1 &= \begin{vmatrix} 1+3i & 4+2i \\ 7 & -2-3i \end{vmatrix} = (1+3i)(-2-3i) - 7(4+2i) = \\ &= -2 - 3i - 6i + 9 - 28 - 14i = -21 - 23i, \end{aligned}$$

$$\Delta_2 = \begin{vmatrix} 3-i & 1+3i \\ 4+2i & 7 \end{vmatrix} = (3-i)7 - (4+2i)(1+3i) =$$

$$= 21 - 7i - (4 + 12i + 2i - 6) = 21 - 7i + 2 - 14i = 23 - 21i,$$

$$z_1 = \frac{\Delta_1}{\Delta} = \frac{-21-23i}{-21-23i} = 1,$$

$$z_2 = \frac{\Delta_2}{\Delta} = \frac{23-21i}{-21-23i} \cdot \frac{-21+23i}{-21+23i} = \frac{-23 \cdot 21 + 23 \cdot 23i + 21 \cdot 21i - 21 \cdot 23i^2}{(-21)^2 - (23i)^2} =$$

$$= \frac{-23 \cdot 21 + i(23^2 + 21^2)i + 21 \cdot 23}{23^2 + 21^2} = i.$$

*Answer:*  $z_1 = 1, z_2 = i$ .

**Example 2.23.** Solve the system of equations

$$\begin{cases} (2+i)z_1 + (3-i)z_2 = 4+2i, \\ (5-2i)z_1 + (2+3i)z_2 = -5i. \end{cases}$$

*Solution:* According to the Kramer method:

$$\Delta = \begin{vmatrix} 2+i & 3-i \\ 5-2i & 2+3i \end{vmatrix} = (2+i)(2+3i) - (5-2i)(3-i) = -12 + 19i,$$

$$\Delta_1 = \begin{vmatrix} 4+2i & 3-i \\ -5i & 2+3i \end{vmatrix} = (4+2i)(2+3i) - (3-i)(-5i) = 7 + 31i,$$

$$\Delta_2 = \begin{vmatrix} 2+i & 4+2i \\ 5-2i & -5i \end{vmatrix} = (2+i)(-5i) - (4+2i)(5-2i) = -19 - 12i,$$

$$z_1 = \frac{\Delta_1}{\Delta} = \frac{7+3i}{-12+19i} = \frac{(7+3i)(-12+19i)}{(-12+19i)(-12+19i)} = \frac{505-505i}{505} = 1-i,$$

$$z_2 = \frac{\Delta_2}{\Delta} = \frac{-19-12i}{-12+19i} = \frac{(-19-12i)(-12-19i)}{(-12+19i)(-12-19i)} = \frac{505i}{505} = i.$$

*Answer:*  $z_1 = 1-i, z_2 = i$ .

### QUESTION FOR SELF-CONTROL:

1. Explain how the numbers  $z$  and  $\bar{z}$ ,  $z$  and  $(-z)$  are related from the geometrical point of view?
2. Find the values of the complex numbers  $z \cdot \bar{z}$ ,  $z + \bar{z}$ ,  $z - \bar{z}$  in terms of the real and imaginary parts of the complex number  $z = x + iy$ .
3. Is it true, that any complex number can be written in trigonometric form? Exponential form?
4. Is it possible for two non-equal complex numbers to have the same trigonometric representation? Is it possible for a complex number to have several different trigonometric representations?
5. Given two complex numbers  $z_1$  and  $z_2$  with the arguments  $\varphi_1$  and  $\varphi_2$ , what is the argument of the product  $z_1 \cdot z_2$ ? What can be said about the argument of the ratio  $\frac{z_1}{z_2}$ ?
6. Can Moivre's formula be applied to bring a complex number to a negative power?
7. Can Moivre's formula be applied to bring a complex number to a rational power?
8. Is it possible to compute the root of degree 3 of any complex number? How many different values will this root have?
9. Is it possible to compute the root of degree 5 of any complex number? How many different values will this root have?
10. Is it possible for a root of degree  $n$  of a complex number to have real values?

**TEST 2. “OPERATIONS WITH COMPLEX NUMBERS”**

1. Compute the imaginary part of the number  $z = (1 - 3i)(1 + i)$ .

A	B	C	D
$3i$	$-2$	$-2i$	$1$

2. What are the Cartesian coordinates of the point  $\bar{z}$ , if  $z = (1 - i)(1 + 2i)$ .

A	B	C	D
$(3,1)$	$(3,-1)$	$(-3,-1)$	$(-3,1)$

3. Compute the real part of the complex number  $z = (1 - 2i)(1 + i)$ .

A	B	C	D
$\frac{i}{2}$	$-1$	$3$	$1$

4. Let  $|z_1| = 2, |z_2| = 3$ . Choose the correct inequality.

A	B	C	D
$1 \leq  z_1 + z_2  \leq 7$	$1 \leq  z_1 + z_2  \leq 5$	$6 \leq  z_1 + z_2  \leq 7$	$5 \leq  z_1 + z_2  \leq 7$

5. Which of the following numbers solve the equation  $z^2 = 15 + 8i$ .

A	B	C	D
$2 + 2i$	$4 + i$	$-4 - i$	$-4 + i$

6. Solve the equality  $(1 + i)z - 4i + 7 = 3 + i$ , assuming that  $z = x + iy$ .

A	B	C	D
$x=1, y=2$	$x=0, y=5$	$x=0, y=-5$	$x=3, y=-2$

7. Let  $z_1 = 2\left(\cos \frac{\pi}{7} + i \sin \frac{\pi}{7}\right)$ ,  $z_2 = 4e^{i\pi}$ . Choose the correct inequality.

A	B	C	D
$1 \leq  z_1 + z_2  \leq 6$	$2 \leq  z_1 + z_2  \leq 6$	$2 \leq  z_1 + z_2  \leq 4$	$2 \leq  z_1 + z_2  \leq 8$

8. The exponential form of the complex number  $z = 2e^{i\frac{3\pi}{4}} \cdot 4e^{3+i\frac{\pi}{4}}$  is

A	B	C	D
$8e^{i\frac{\pi}{4}}$	$8e^{3i}$	$8e^{i\frac{\pi}{3}}$	$-8e^3$

9. The trigonometric form of the complex number  $z = 2e^{i\frac{\pi}{2}} \cdot 3e^{2+i\frac{\pi}{4}}$  is

A	$6e^2 \left( \cos \frac{3\pi}{4} + i \sin \frac{3\pi}{4} \right)$	B	$-6e^2 \left( \cos \frac{3\pi}{4} + i \sin \frac{3\pi}{4} \right)$
C	$6e^2 \left( \cos \frac{3\pi}{4} + i \sin \frac{3\pi}{4} \right)$	D	$6e^2 \left( \cos \frac{3\pi}{4} - i \sin \frac{3\pi}{4} \right)$

10. Among the given numbers choose those, which solve the equation  $z^3 = -1$ .

A	$\left( \cos \frac{2\pi}{3} + i \sin \frac{2\pi}{3} \right)$	B	$\left( \cos \frac{5\pi}{3} + i \sin \frac{5\pi}{3} \right)$
C	$(\cos \pi + i \sin \pi)$	D	$\left( \cos \frac{\pi}{3} + i \sin \frac{\pi}{3} \right)$

### TASKS FOR INDIVIDUAL WORK:

1. Compute:

1.1.  $(2i + 5)(2 - 3i)$ ;

*Answer:*  $16 - 11i$ .

1.2.  $(3 - i)(1 - 4i)$ .

*Answer:*  $-1 - 13i$ .

2. Write down the algebraic representation of the given complex numbers:

2.1.  $\frac{3 - 4i}{1 + 2i}$ ;

*Answer:*  $-1 - 2i$ .

2.2.  $\frac{7 + 2i}{5i}$ ;

*Answer:*  $-\frac{2}{5} - \frac{7}{5}i$ .

$$2.3. \frac{1+i \operatorname{tg} \alpha}{1-i \operatorname{tg} \alpha}$$

*Answer:*  $\cos 2\alpha + i \sin 2\alpha$ .

$$2.4. \frac{a+bi}{a-bi};$$

$$\text{Answer: } \frac{a^2 - b^2}{a^2 + b^2} + i \frac{2ab}{a^2 + b^2}.$$

3. Calculate:

$$3.1. (2-2i)^7;$$

$$\text{Answer: } 2^{10}(1+i).$$

$$3.2. \left( \frac{1+\sqrt{3}i}{1-i} \right)^{40};$$

$$\text{Answer: } -2^{19}(1+\sqrt{3}i).$$

$$3.4. (\sqrt{3}-3i)^6;$$

$$\text{Answer: } 1728.$$

$$3.5. \left( \frac{1-i}{1+i} \right)^8;$$

$$\text{Answer: } 1.$$

$$3.6. \frac{2+3i}{(1+i)^2};$$

$$\text{Answer: } \frac{3}{2} - i.$$

$$3.7. \left( \cos \frac{2\pi}{3} + i \sin \frac{2\pi}{3} \right)^{33};$$

$$\text{Answer: } 1.$$

$$3.8. \left( \cos \frac{2\pi}{5} - i \sin \frac{2\pi}{5} \right)^{15};$$

*Answer:* 1.

$$3.9. (1 + i\sqrt{3})^9;$$

*Answer:* -512.

$$3.10. \left( -\cos \frac{\pi}{7} - i \sin \frac{\pi}{7} \right)^{56};$$

*Answer:* 1.

4. Find all values of the roots:

$$4.1. \sqrt[4]{-1};$$

$$\text{Answer: } w_0 = \frac{1}{\sqrt{2}}(1+i), w_1 = \frac{1}{\sqrt{2}}(1-i), \\ w_2 = -\frac{1}{\sqrt{2}}(1+i), w_3 = -\frac{1}{\sqrt{2}}(1-i).$$

$$4.2. \sqrt{i};$$

$$\text{Answer: } w_0 = \frac{1}{\sqrt{2}}(1+i), w_1 = -\frac{1}{\sqrt{2}}(1+i).$$

$$4.3. \sqrt[3]{i};$$

$$\text{Answer: } w_0 = \frac{1}{2}(\sqrt{3} + i), w_1 = \frac{1}{2}(-\sqrt{3} + i), w_2 = -i.$$

$$4.4. \sqrt[4]{-i};$$

$$\text{Answer: } w_0 = \cos \frac{\pi}{8} - i \sin \frac{\pi}{8}, w_1 = -\cos \frac{\pi}{8} + i \sin \frac{\pi}{8}, \\ w_2 = \cos \frac{3\pi}{8} + i \sin \frac{3\pi}{8}, w_3 = -\cos \frac{3\pi}{8} - i \sin \frac{3\pi}{8}.$$

$$4.5. \sqrt{2 - 2\sqrt{3}i};$$

$$\text{Answer: } w_0 = \sqrt{3} - i, w_1 = -\sqrt{3} + i.$$

5. Compute:

$$5.2. \frac{(-\sqrt{3}-i)e^{i\frac{5\pi}{6}}}{\cos\frac{2\pi}{3}+i\sin\frac{2\pi}{3}};$$

*Answer:*  $-1-\sqrt{3}i$ .

$$5.3. \frac{(-1+i)e^{i\frac{\pi}{4}}}{\cos\frac{\pi}{3}+i\sin\frac{\pi}{3}}.$$

*Answer:*  $1+i$ .

6. Compute:

$$6.1. \sqrt[4]{-1-i\sqrt{3}};$$

$$\text{Answer: } w_0 = 2^{\frac{1}{4}}\left(\frac{\sqrt{3}}{2}-i\frac{1}{2}\right), w_1 = 2^{\frac{1}{4}}\left(\frac{1}{2}+i\frac{\sqrt{3}}{2}\right),$$

$$w_2 = 2^{\frac{1}{4}}\left(-\frac{\sqrt{3}}{2}+i\frac{1}{2}\right), w_3 = 2^{\frac{1}{4}}\left(-\frac{1}{2}-i\frac{\sqrt{3}}{2}\right).$$

$$6.2. \sqrt[4]{-1+i\sqrt{3}};$$

$$\text{Answer: } w_0 = 2^{\frac{1}{4}}\left(\frac{\sqrt{3}}{2}+i\frac{1}{2}\right), w_1 = 2^{\frac{1}{4}}\left(-\frac{1}{2}+i\frac{\sqrt{3}}{2}\right),$$

$$w_2 = 2^{\frac{1}{4}}\left(-\frac{\sqrt{3}}{2}-i\frac{1}{2}\right), w_3 = 2^{\frac{1}{4}}\left(\frac{1}{2}-i\frac{\sqrt{3}}{2}\right).$$

$$6.3. (1+i)^4(1-i\sqrt{3})^{-12};$$

*Answer:*  $-\frac{1}{1024}$ .

$$6.4. (1-i)^5(1-i^{19})^2;$$

*Answer:*  $-8-8i$ .

7. Prove the equality:  $\overline{z_1 \cdot z_2} = \bar{z}_1 \cdot \bar{z}_2$ .

8. Solve the system of equations

$$8.1. \quad \begin{cases} (2+i)z_1 + (2-i)z_2 = 6, \\ (3+2i)z_1 + (3-2i)z_2 = 8. \end{cases}$$

$$\text{Answer: } z_1 = 2+i, z_2 = 2-i.$$

$$8.2. \quad \begin{cases} (3-i)z_1 + (4+2i)z_2 = 2+6i, \\ (4+2i)z_1 - (2+3i)z_2 = 5+4i. \end{cases}$$

$$\text{Answer: } z_1 = 1+i, z_2 = i.$$

$$8.3. \quad \begin{cases} z_1 + z_2 i - 2z_3 = 10, \\ z_1 - z_2 + 2iz_3 = 20, \\ iz_1 + 3iz_2 - (1+i)z_3 = 30. \end{cases}$$

$$\text{Answer: } z_1 = 3-11i, z_2 = -3-9i, z_3 = 1-7i.$$

9. Find the real solution of the equation

$$9.1. \quad (3x-i)(2+i) + (x-iy)(1+2i) = 5-6i.$$

$$\text{Answer: } x = \frac{20}{17}, y = -\frac{36}{17}.$$

$$9.2. \quad (1+2i)x + (3-5i)y = 1-3i.$$

$$\text{Answer: } x = -\frac{4}{11}, y = \frac{5}{11}.$$

10. Prove that

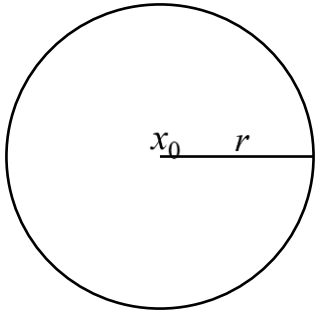
$$\left( \frac{1+i \operatorname{tg} \alpha}{1-i \operatorname{tg} \alpha} \right)^n = \frac{1+i \operatorname{tg} n\alpha}{1-i \operatorname{tg} n\alpha}.$$

### 3. DOMAINS AND CURVES IN COMPLEX PLAIN

Remember that by the definition the modulus of a complex number  $z = x + iy$  is the distance between the points  $(0,0)$  and  $(x, y)$  in the complex plain computed by the formula  $|z| = |x + iy| = \sqrt{x^2 + y^2}$ . Then, the equality  $|z| = r$  determines a circle in the complex plain of radius  $r$  centered at the origin  $(0,0)$ .

**Definition 3.1.** The equality  $|z - z_0| = r$  determines a circle in the complex plain of radius  $r$  centered at the point  $z_0(x_0, y_0)$  (see Fig 3.1).

Indeed, considering the distance between two points  $z = x + iy$ ,  $z_0 = x_0 + iy_0$ , we have



$$\begin{aligned} |z - z_0| &= |x + iy - x_0 - iy_0| = |x - x_0 + i(y - y_0)| = \\ &= \sqrt{(x - x_0)^2 + (y - y_0)^2} = r, \\ (x - x_0)^2 + (y - y_0)^2 &= r^2. \end{aligned}$$

Fig. 3.1.

**Example 3.1.** Plot the set of points in the complex plain given by the equality  $|z + 1 - 2i| = 2$ .

*Solution:*

$$|z + 1 - 2i| = |z - (-1 + 2i)| = 2.$$

*Answer:* the given equality determines the circle centered at the point  $z_0 = -1 + 2i$  of radius  $r = 2$  shown in Fig. 3.2.

The inequality  $|z - z_0| < r$  determines the interior of the circular disk centered at the point  $z_0$  of radius  $r$ . The inequality  $|z - z_0| \leq r$  describes then the

disk centered at the point  $z_0$  of radius  $r$  including its circular boundary. The inequality  $|z - z_0| > r$  determines the exterior of the circular disk, whereas the inequality  $|z - z_0| \geq r$  describes the exterior of the disc including the circle  $|z - z_0| = r$ .

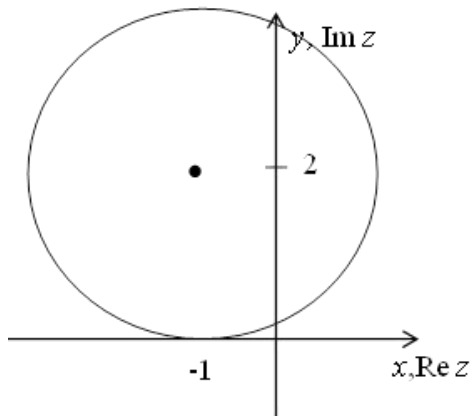


Fig. 3.2.

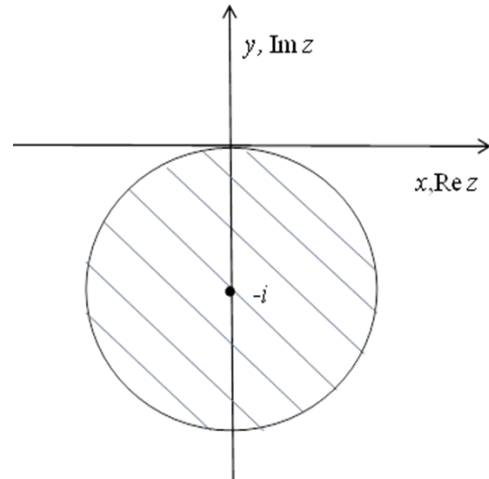


Fig. 3.3.

**Example 3.2.** Plot the set of points in the complex plan given by the inequality  $|z + i| \leq 1$ .

*Solution:*

$$|z + i| = |z - (-i)| \leq 1.$$

*Answer:* the given inequality determines the circular disc centered at the point  $z_0 = -i$  of radius  $r = 1$  including its boundary, as shown in Fig. 3.3.

**Example 3.3.** Plot the set of points in the complex plain given by the inequality  $|z - 3 + i| > 2$ .

*Solution:*

$$|z - 3 + i| = |z - (3 - i)| > 2$$

*Answer:* the inequality describes the exterior of the circle centered at the point  $z_0 = 3 - i$  of radius  $r = 2$ , see Fig. 3.4.

**Example 3.4.** Plot the set of points in the complex plain given by the two-sided inequality  $1 < |z - 1 + i| \leq 2$ .

*Solution:*

$$|z - 1 + i| = |z - (1 - i)|.$$

*Answer:* The given inequality determines the intersection of two sets, namely, the exterior of the circular disk centered at the point  $z_0 = 3 - i$  of radius  $r_1 = 1$  and the interior of the disk with the same center but of radius  $r_2 = 2$ , including the boundary circle (see Fig. 3.5).

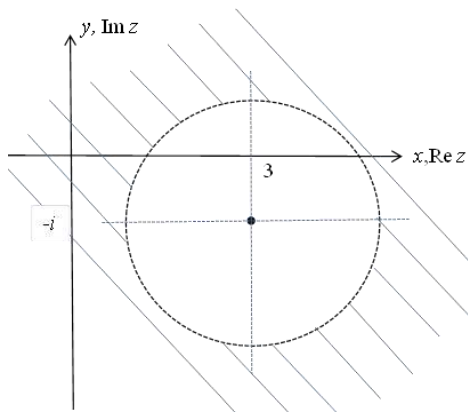


Fig. 3.4.

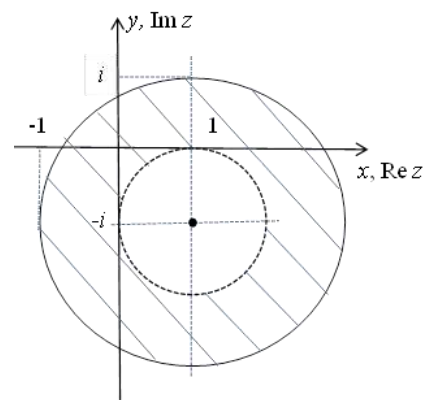


Fig. 3.5.

**Definition 3.2.** For any given number  $\varphi: -\pi \leq \varphi < \pi$ , the equation  $\arg z = \varphi$  determines a *ray* in the complex plain starting at the origin such that the angle between the ray and the positive direction of the real axis is  $\varphi$ . The angle can be both positive and negative. The sign of  $\varphi$  determines the direction of the rotation from the real axis towards the ray. In case  $\varphi > 0$ , the rotation is counterclockwise; for  $\varphi < 0$  it is clockwise; if  $\varphi = 0$ , the ray coincides with the positive direction of the real axis. We note that the origin itself does not belong to the ray, since the argument is not determined for this point.

**Definition 3.3.** The inequality  $\varphi_0 \leq \arg z \leq \varphi_1$  determines the angle in the complex plain bounded by the rays  $\varphi = \varphi_1$  and  $\varphi = \varphi_2$ . Whether the rays themselves belong to the domain depends on whether the inequalities are strict or not.

**Example 3.5.** Plot the set of points in the complex plain given by the inequality

$$\frac{\pi}{6} \leq \arg z < \frac{\pi}{4}.$$

*Solution:* definition 3.3 implies that the inequality  $\frac{\pi}{6} \leq \arg z < \frac{\pi}{4}$  deter-

mines the angle between the rays  $\varphi = \frac{\pi}{6}$  and  $\varphi = \frac{\pi}{4}$ .

*Answer:* see Fig. 3.6.

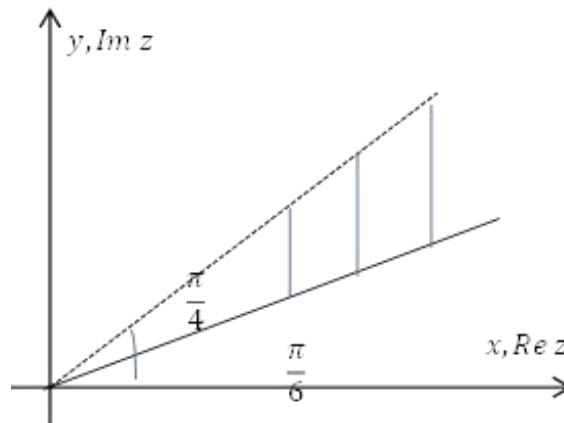


Fig. 3.6.

**Definition 3.4.** Consider a line in the plane, whose equation in the Cartesian coordinates is  $y = kx$ . Then its complex equation is  $\varphi = \arg z$ , where  $\text{tg } \varphi = k$ ,  $z \neq 0$ .

The horizontal line having the intercept with the  $Oy$  axis at the point  $y = b$ , i.e. the one passing through the point  $z = 0 + bi$ , is given by the equation

$$\text{Im } z = b.$$

The vertical line having the intercept with the  $Ox$  axis at the point  $x=a$ , i.e. passing through the point  $z=a+0i$ , is given by the equation

$$\operatorname{Re} z = a.$$

The rectangle (Fig. 3.7) together with its bound can be specified using a system of inequalities

$$-a \leq \operatorname{Re} z \leq b \quad |\operatorname{Im} z| \leq d.$$

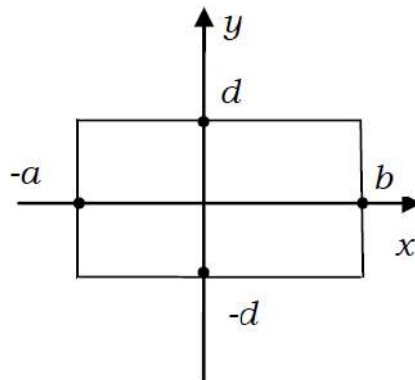


Fig. 3.7.

Another example of a simple geometric interpretation of the image of complex numbers on the plane is a set of points which is given by the equality

$$|z - a| + |z - b| = c,$$

where  $a$  and  $b$  are complex numbers, and  $c > 0$ . It is obvious that if  $|a - b| = c$ , this set is the segment connecting the points  $a$  and  $b$ , and if  $|a - b| > c$ , this set is an empty set. If  $|a - b| < c$ , then this is the set of points  $z$ , the sum of the distances from which to two of fixed points  $a$  and  $b$  is a constant value equal to  $c$ . As known from analytic geometry, such a set of points is an *ellipse with foci at points  $a$  and  $b$* .

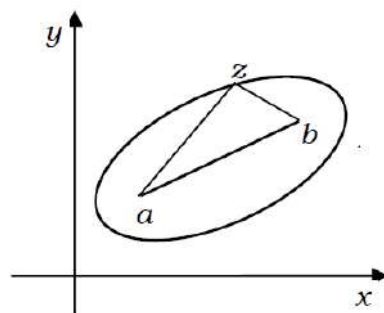


Fig. 3.8.

**Example 3.6.** Plot the set of points in the complex plain given by the inequality

$$|\operatorname{Re}(4z - i)| < 8.$$

*Solution:*

$$\operatorname{Re}(4z - i) = \operatorname{Re}(4x + 4iy - i) = 4x, \quad |4x| < 8, \quad -8 < 4x < 8, \quad -2 < x < 2.$$

*Answer:* the required set is the vertical strip  $-2 < x < 2$  (see Fig. 3.9).

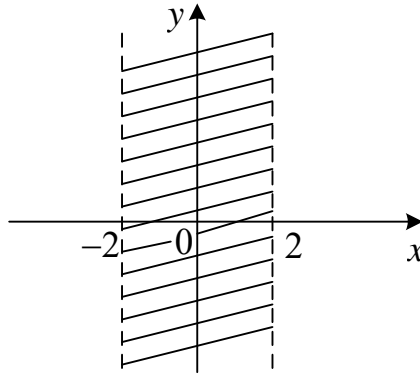


Fig. 3.9.

**Example 3.7.** Plot the set of points in the complex plain given by the inequality

$$0 < \operatorname{Im} z \leq 1.$$

*Solution:*  $\operatorname{Im} z = y, 0 < y \leq 1.$

*Answer:* the given inequality determines the horizontal line  $0 < y \leq 1$  (see Fig. 3.10).

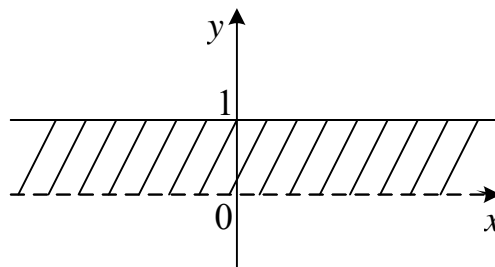


Fig. 3.10.

**Example 3.8.** Plot the set of points in the complex plain given by the inequality

$$\operatorname{Re} z > 3.$$

*Answer:* the given inequality determines the half-plane shown in Fig. 3.11.

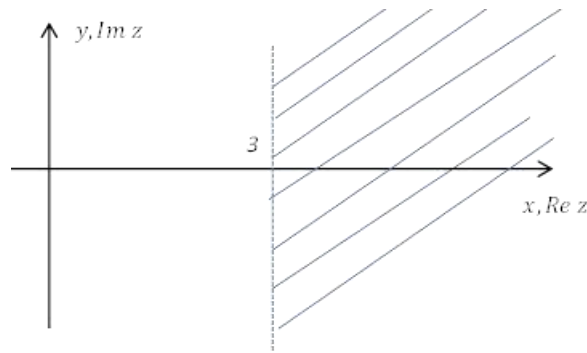


Fig. 3.11.

**Example 3.9.** Plot the set of points in the complex plain whose coordinates satisfy simultaneously the both inequalities  $|z - 2i| \leq 2$  and  $1 \leq \text{Im } z \leq 3$ .

*Answer:* the required domain is shown in Fig. 3.12.

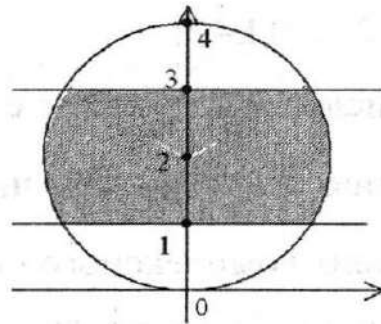


Fig. 3.12.

The distance  $d$  between two points  $z_1 = x_1 + iy_1$ ,  $z_2 = x_2 + iy_2$  in the complex plain  $\mathbb{C}$  is given by the formula:

$$d = |z_1 - z_2| = \sqrt{(x_1 - x_2)^2 + (y_1 - y_2)^2}.$$

This formula introduces the metric in  $\mathbb{C}$ .

**Example 3.10.** Point out the line types corresponding to the following relations:

- 1)  $\text{Re } z^2 = 16$ ;
- 2)  $z = z_0 + R e^{i\varphi}$ ;
- 3)  $|z - 3 + 2i| = 3$ ;
- 4)  $|z - 2i| + |z + 2i| = 6$
- 5)  $|z - 3 + 2i| = |z|$ .

*Solution:*

1)  $\operatorname{Re} z^2 = \operatorname{Re}(x+iy)^2 = \operatorname{Re}(x^2 + 2xyi - y^2) = x^2 - y^2$ . Then the equation  $\operatorname{Re} z^2 = 16$  will take the form  $x^2 - y^2 = 16$ .

*Answer:* this equation defines an equilateral hyperbola centered at  $(0, 0)$  (see Fig. 3.13).

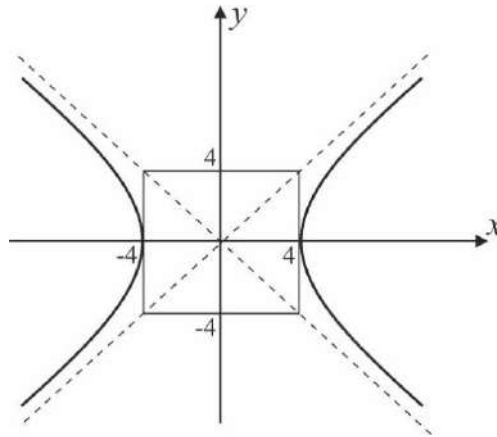


Fig 3.13.

2) We can write the equality  $z = z_0 + R e^{i\varphi}$  in the form:

$$x + iy = x_0 + iy_0 + R(\cos \varphi + i \sin \varphi).$$

Equating the real and imaginary parts we get

$$\begin{cases} x = x_0 + R \cos \varphi, \\ y = y_0 + R \sin \varphi. \end{cases}$$

If  $\varphi \in [0, 2\pi)$  then these equations define a circle  $(x - x_0)^2 + (y - y_0)^2 = R^2$  with the center at the point  $(x_0, y_0)$  and its radius is  $R$ ; if  $\varphi \in [0, \pi]$ .

*Answer:* these equations define only upper part of the circle (see Fig. 3.14).

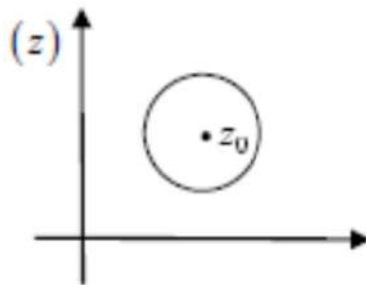


Fig 3.14.

***It should be noticed that the equation of circle on the complex plane can be***

*presented in both of the forms:*

$$z = z_0 + R e^{i\varphi}, \varphi \in [0, 2\pi) \text{ or } |z - z_0| = R.$$

3) We can write the equality  $|z - 3 + 2i| = 3$  in the form:  $|z - (3 - 2i)| = 3$ .

*Answer:* it defines a circle centered at a point  $z_0 = 3 - 2i$  of radius  $R = 3$  (see Fig. 3.15).

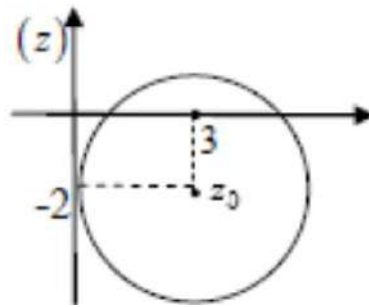


Fig 3.15.

4) In the equation  $|z - 2i| + |z + 2i| = 6$ , the modulus  $|z - 2i|$  is a distance from a point  $z$  to the point  $z_0 = 2i$ , and the modulus  $|z + 2i| = |z - (-2i)|$  is a distance from a point  $z$  to the point  $z_1 = -2i$ . Consequently, the equation  $|z - 2i| + |z + 2i| = 6$  defines a set of the points  $z$ , for which the sum of distances from them to the two given points  $z_0 = 2i$  and  $z_1 = -2i$  is a constant value equal to 6, and is bigger than the distance between those points  $z_0 = 2i$  and  $z_1 = -2i$ .

*Answer:* this set of the points associates with ellipse whose foci are at the points  $z_0 = 2i$  and  $z_1 = -2i$ . Herewith, the big axis containing the foci has a length equal to 6 (see Fig. 3.16).

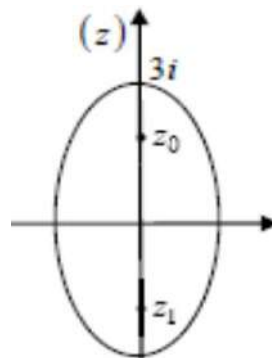


Fig 3.16.

5) In the equation  $|z - 3 + 2i| = |z|$ , the modulus  $|z - 3 + 2i|$  is a distance from a point  $z$  to the point  $z_0 = 3 - 2i$ , and the modulus  $|z| = |z - 0|$  is a distance from a point  $z$  to the point  $z_1 = 0$ . In this regard, the equation  $|z - 3 + 2i| = |z|$  defines a set of the points  $z$  equally spaced from the points  $z_0 = 3 - 2i$  and  $z_1 = 0$ .

*Answer:* this set of the points is a middle line normal to the segment  $z_0z_1$  (see Fig. 3.17).

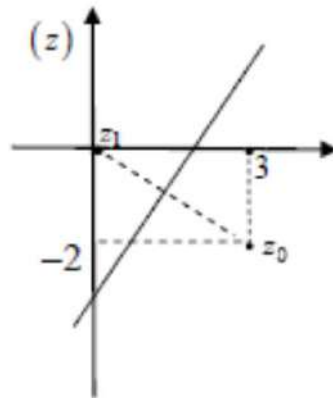


Fig 3.17.

**Definition 3.5.** The set of the points in the complex plain contained inside the circle of radius  $\varepsilon$  centered at the point  $z_0$ , is called the  $\varepsilon$ - neighborhood of the point  $z_0$ .

The definition implies that the  $\varepsilon$  - neighborhood of the point  $z_0$  consists of the points in the complex plain whose coordinates satisfy the inequality  $|z - z_0| < \varepsilon$  (Fig.3.18).

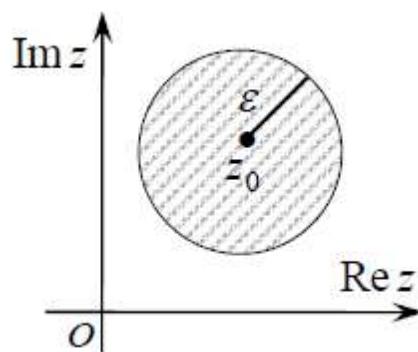


Fig. 3.18.

**Definition 3.6.** The *neighborhood of the infinity*  $z = \infty$  is the set consisting of all points  $z \in \mathbb{C}$  such that  $|z| > R$ , and the point  $z = \infty$  itself.

**Definition 3.7.** The point  $a$  is called the *interior point* of the set  $E$  in the complex plane if there exists an  $\varepsilon$  - neighborhood of this point lying entirely in  $E$ .

**Definition 3.8.** The point  $b$  is the *boundary point* of  $E \subset \mathbb{C}$  if any  $\varepsilon$  - neighborhood of this point contains the points that belong to  $E$  as well as those that don't.

**Definition 3.9.** The point  $c$  is the *limit point* of the set  $E$  if any neighborhood of  $c$  contains points of  $E$  other than  $c$  itself.

**Definition 3.10.** The point  $d$  is an *isolated point* of  $E$  if  $d \in E$  and there exists an  $\varepsilon$  - neighborhood of  $d$  that does not contain points of  $E$  other than  $d$ .

**Definition 3.11.** The point  $m$  is the *exterior point* of the set  $E$  in the complex plane if there exists an  $\varepsilon$  - neighborhood of this point that does not lie in  $E$  entirely.

The interior, boundary, limit, isolated and exterior points of a set in complex plane are shown in Fig. 3.19.

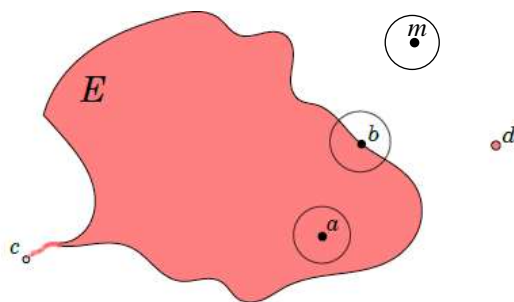


Fig. 3.19.

**Definition 3.12.** We say that the set  $E \subset \mathbb{C}$  is *open* if all of its points are its interior points.

**Definition 3.13.** A *closed* set is a set containing all its limit points.

**Definition 3.14.** The union of all boundary points of the set  $E \subset \mathbb{C}$  is called the *boundary* of  $E$ . The boundary of the set  $E$  is denoted by  $\partial E$ .

The boundary of the set  $D$  in the complex plain can be given by a complex-valued function  $z = z(t) = x(t) + iy(t)$  of the real argument  $t \in [\alpha, \beta]$ . Defining this complex-valued function is equivalent to introducing two real-valued functions  $x(t)$  and  $y(t)$ . The equation

$$z = z(t) = x(t) + iy(t), \quad t \in [\alpha, \beta],$$

is called the *parametric equation of the curve*. Given two points  $z_1 = z(t_1)$  and  $z_2 = z(t_2)$  on the curve such that  $\alpha \leq t_1 < t_2 \leq \beta$ , one says that the point  $z_2$  follows the point  $z_1$ .

Thus, a curve is in fact an oriented set of points in the complex plain. Its *positive orientation* coincides conventionally with the direction of growth of the parameter  $t$ .

**Example 3.11.** The equation  $z = \cos t$ ,  $\pi \leq t \leq 2\pi$  determines the segment  $[-1, 1]$  of the real axis whose orientation is in the direction from the point  $z = -1$  to the point  $z = 1$ .

**Example 3.12.** The equation  $z = e^{it}$ ,  $0 \leq t \leq \pi$  determines the half-circle  $|z| = 1$ ,  $\text{Im } z \geq 0$  oriented counterclockwise. Indeed,  $z = e^{it} = \cos t + i \sin t \Rightarrow x(t) = \cos t$ ,  $y(t) = \sin t$  which implies  $|z| = 1$  and  $\text{Im } z \geq 0$  since  $0 \leq t \leq \pi$ .

**Definition 3.15.** A *simple curve* is a curve which does not cross itself.

**Definition 3.16.** We say that a curve is *smooth (or differentiable)* if the functions  $x(t)$ ,  $y(t)$  are continuously differentiable in the interval  $[\alpha, \beta]$ . A curve is *piecewise smooth* if it is a union of a finite number of smooth curves.

Below we consider only piecewise smooth curves and domains whose boundaries are piecewise smooth.

**Example 3.13.** Fig. 3.20 shows the domain  $|z| < 1$ ,  $0 < \arg z < 2\pi$ .

It is the interior of the circular disk  $|z| < 1$  with a cut along the segment  $[0, 1]$ . The boundary of the domain consists of the segment  $[0, 1]$ , which is traced twice: the first time in the direction from the point  $z = 1$  toward the point  $z = 0$  (lower edge of the cut), the second time from  $z = 0$  toward  $z = 1$  (upper edge of the cut); and the circle  $|z| = 1$  traced counterclockwise.

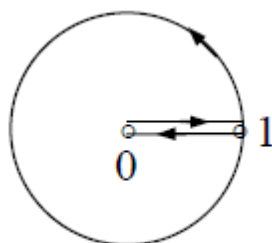


Рис. 3.20.

**Definition 3.17.** The set  $E \subset \mathbb{C}$  is said to be *connected* if any two points of  $E$  can be connected by a polygonal chain contained entirely in  $E$  (see Fig. 3.21), if otherwise, the set  $E$  is said to be *disconnected* (see Fig. 3.22).

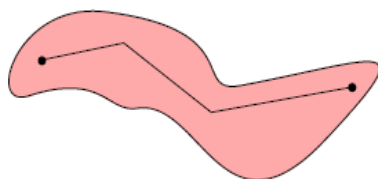


Fig. 3.21. Connected set.

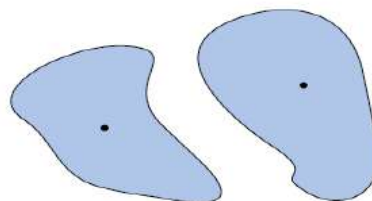


Fig 3.22. Disconnected set.

**Definition 3.18.** An open connected set is called *domain*.

**Definition 3.19.** A *closed domain* is a set obtain by supplementing a domain by all its boundary points. Given the domain  $G$  and its boundary  $\partial G$ , the *closure* of the domain  $G$  is the set  $\bar{G} = G \cup \partial G$ .

Consider the closed domain  $\bar{D}$  shown in Fig. 3.23. The boundary of this domain consists of two curves  $\partial D = \Gamma_1 \cup \Gamma_2$ . The point  $z_1$  is an interior point of the domain and  $z_2$  is its boundary point.

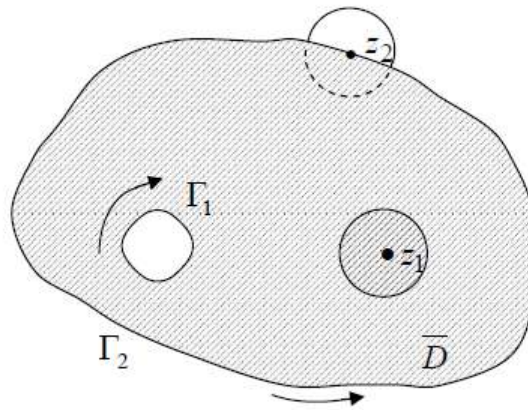


Fig. 3.23.

One of the important notions of the theory of the function of complex variable is the notion of *orientation* of a closed domain. Orientation of a closed domain  $D$  is determined by the orientation of its boundary, i.e. by the choice of the direction of circulation about the boundary. The positive orientation of the boundary is conventionally supposed to be the one by which the domain stays to the left with respect to the direction of circulation about the boundary, as shown by the arrows in Fig. 3.23.

Domains in the complex plain  $\mathbb{C}$  can be either *simply* or *multiply connected*.

**Definition 3.20.** A domain is *simply connected* if its boundary consists of a single simple continuous curve (possibly closed). If otherwise, the domain is *multiply connected*.

An example of a simply connected domain is shown in Fig. 3.24.

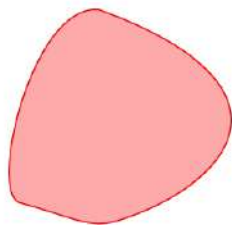


Fig. 3.24.

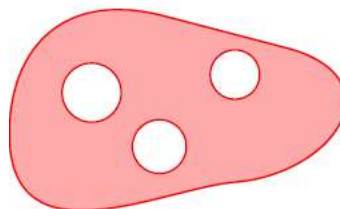


Fig. 3.25.

The *order of connectivity* of a multiply connected domain is the number of simple continuous components in its boundary. An example of multiply connected domain is shown in Fig. 3.25. The order of connectivity of this domain is four (4-connected domain), since its boundary consists of four simple continuous components. Below we consider only domains that have finite order of connectivity.

**Example 3.14.** Prove that the domain  $D = \{z : |z - z_0| < r\}$  is open.

*Solution:* consider a point  $z_1 \in D$ . Then  $|z_1 - z_0| < r$  and the distance between  $z_1$  and the circle  $|z - z_0| = r$  is  $d = r - |z_1 - z_0| > 0$ . If  $0 < \delta < d$ , the set  $|z - z_0| < \delta$  lies entirely in  $D$ . Hence, by Definition 3.12  $D$  is an open set.

**Example 3.15.** Which of the following sets are domains:  $|z - z_0| < R$ ;  $r < |z - z_0| < R$  ( $0 < r < R$ ); the whole complex plain  $\mathbb{C}$ ; half-plane  $\operatorname{Re} z > a$  (where  $a$  is a real number);  $|z - z_0| \leq R$ ?

*Solution:* by Definition 3.18 the following sets are domains: the circular disk  $|z - z_0| < R$ , the ring  $r < |z - z_0| < R$  ( $0 < r < R$ ), the complex plain  $\mathbb{C}$ , the half-plane  $\operatorname{Re} z > a$  (where  $a$  is a real number). The disk  $|z - z_0| \leq R$  is not a domain since this set is not open. The points  $z$  satisfying  $|z - z_0| = R$  do not have neighborhoods lying entirely in the domain.

**Example 3.16.** Give an example of a simply connected domain.

*Solution:* the examples of simply connected domains are the circular disk  $|z - z_0| < r$  and half-plane  $\operatorname{Re} z > 0$ .

**Definition 3.21.** The domain  $E \subset \mathbb{C}$  is *bounded* if there exists a circle  $B(0, R)$ , of radius  $R < \infty$  centered at the origin such that  $E \subset B(0, R)$ . The latter inclusion means that  $|z| < R \quad \forall z \in E$ .

A bounded domain is shown in Fig. 3.26.

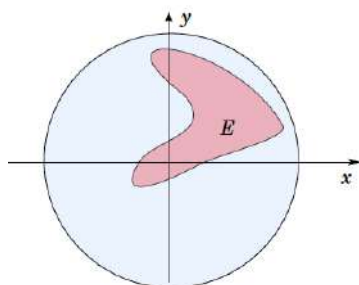


Fig. 3.26.

### QUESTIONS FOR SELF-CONTROL:

1. Which points  $z$  in the complex plain satisfy the property  $z = \bar{z}$ ,  $z \in \mathbb{C}$ .
2. Explain the geometrical connection between the points  $z_0$  and  $\frac{1}{z_0}$  if  $|z_0| < 1$ ?
3. Does the point  $z = 2 + i$  belongs to the disk  $|z - i| < 2$ ?
4. Does the point  $z = i - 1$  belong to the circle  $|z + i| = 1$ ?
5. Is the curve  $z = 2e^{it}$ ,  $t \in [0; \pi]$  simple? Is it closed?
6. Is  $z = i + 1$  a boundary point of the set  $E = \{z \in \mathbb{C} : |z + i| = 1\}$ ?
7. Is  $z = -i + 1$  an internal point of the set  $E = \{z \in \mathbb{C} : |z + i| = 1\}$ ?
8. Is the set  $E = \{z \in \mathbb{C} : 2 < |z + i| < 3\}$  a domain?
9. Is the set  $E = \{z \in \mathbb{C} : 2 < |z - i| < 4\}$  connected? Is it bounded?
10. How can the set of the points whose distance to the imaginary axis is less than 1 can be described analytically? What is the name for such set of the points?

### TEST 3.

1. Which of the following curves is closed?

A	B	C	D
segment connecting the points $z_1 = 1$ and $z_2 = 1 + i$	$z = 3 + 2e^{i\alpha},$ $\alpha \in [0, \pi]$	$z = 1 + 3e^{i\alpha},$ $\alpha \in [0, 2\pi]$	$z = re^{i\frac{\pi}{3}},$ $r \in (2, 7)$

2. Which of the following domains is disconnected?

A	B	C	D
$E = \{z \in \mathbb{C} :  z + i  < 1\}$	$E = \{z \in \mathbb{C} :  z + i  < 1,$ $\operatorname{Re} z > 3\}$	$E = \{z \in \mathbb{C} :$ $0 <  z - i  < 1\}$	$E = \{z \in \mathbb{C} :$ $1 <  z + i  < 2\}$

3. Which of the following points belong to the circle  $|z - 2| = 2$ ?

A	B	C	D
$\frac{i}{4}$	$2i$	$0$	$2 - 2i$

4. Let  $|z_1| = 2, |z_2| = 3$ . Chose the correct inequality.

A	B	C	D
$1 \leq  z_1 + z_2  \leq 7$	$1 \leq  z_1 + z_2  \leq 5$	$6 \leq  z_1 + z_2  \leq 7$	$5 \leq  z_1 + z_2  \leq 7$

5. Which of the following numbers belong to the disk  $|z - 2| \leq 2$ ?

A	B	C	D
$2i$	$1 + 2i$	$-1$	$2 - 2i$

6. Which of the following numbers satisfies the inequality  $\operatorname{Re} z + \operatorname{Im} z < 1$ ?

A	B	C	D
$2i$	$1$	$-3 + i$	$3 - i$

7. Let  $z_1 = 2\left(\cos\frac{\pi}{7} + i\sin\frac{\pi}{7}\right)$ ,  $z_2 = 4e^{i\pi}$ . Choose the correct inequality.

A	B	C	D
$1 \leq  z_1 + z_2  \leq 6$	$2 \leq  z_1 + z_2  \leq 6$	$2 \leq  z_1 + z_2  \leq 4$	$2 \leq  z_1 + z_2  \leq 8$

8. The circle of radius 5 centered at the point (0; 1) is given by the equation:

A	B	C	D
$ z + i  = 5$	$ z - i  = 25$	$ z - i  = 5$	$ z + 1  = 5$

9. The circle of radius 3 centered at the point (-2; 1) is given by the equation:

A	B	C	D
$ z + 2i - 1  = 3$	$ z - 2 + i  = 3$	$ z + 2 - i  = 3$	$ z + 2 - i  = 9$

10. Give the analytic description (using inequalities) of the domain  $D$  whose boundary is described by the function  $z = 3 + 5e^{it}$ ,  $0 \leq t \leq 2\pi$ .

A	$ z - 5  \leq 3$	B	$ z - 5  < 3$
C	$ z - 3  \leq 5$	D	$ z - 5  < 3$

## TASKS FOR INDIVIDUAL WORK:

1. Plot the set of points in the plain given analytically by the following relations:

1.1.  $\operatorname{Re} z = 1;$

1.6.  $\frac{\pi}{4} < \arg(z+i) < \frac{\pi}{2};$

1.2.  $|\operatorname{Im} z| < 1;$

1.7.  $\frac{\pi}{3} < \left| \arg(z) - \frac{\pi}{3} \right| < \frac{\pi}{2};$

1.3.  $|\operatorname{Im} z - 1| \leq 2;$

1.8.  $\begin{cases} |\operatorname{Im} z - 1| < 1, \\ |\operatorname{Re} z + 1| > 2; \end{cases}$

1.4.  $|z - 2| = 3;$

1.9.  $z \cdot \bar{z} = \operatorname{Re}(4z);$

1.5.  $1 < |z - 1 + i| < 3;$

1.10.  $\operatorname{Im}(z - 3i) - 2 \geq \operatorname{Re} z.$

2. Describe analytically (using inequalities) the following sets in the complex plain:

2.1. Half-plane situated to the right of the imaginary axis;

2.2. Half-plane consisting of the points of the complex plain situated above the real axis at the distance which is greater or equal to 4;

2.3. Circular disk of the radius 3 centered at the point  $z = 2 + 3i$ ;

2.4. The third quadrant of the complex plain.

3. Describe, which curves are given by the following equations:

3.1.  $z = re^{i\frac{\pi}{3}}, r \in (2, 5);$

3.2.  $z = 3e^{i\alpha}, \alpha \in \left[ \frac{\pi}{3}, \frac{\pi}{2} \right);$

3.3.  $z = a + (b - a)t, t \in [0, 1];$

3.4.  $z = t^2 + it, t \in [0, +\infty).$

4. Describe analytically (using inequalities) the domain  $D$ , whose boundary is the closed curve given by the parametric equation:

4.1.  $z = a + re^{i\alpha}, \alpha \in [0, 2\pi];$

- 4.2.  $z = 1 - it, t \in (-\infty, +\infty)$ ;
- 4.3.  $z = t + it^2, t \in (-\infty, +\infty)$ .
5. Write down the parametric equations of the following curves:
- 5.1. Circle of radius 4 centered at the point  $z = 2 - i$ ;
- 5.2. Line segment between the points  $z_1 = 1$  and  $z_2 = 1 + i$ ;
- 5.3. Line segment between the points  $z_1 = 0$  and  $z_2 = 1 + i$ ;
- 5.4. Line segment between the points  $z_1 = 1 + i$  and  $z_2 = 2 + 2i$ ;
- 5.5. The arc of the circle of radius 3 centered at the point  $z = 0$  situated in the first quadrant of the complex plain;
6. Let  $z_1$  and  $z_2$  be two fixed points in the complex plain.
- 6.1. Remember, that ellipse is a curve in the plane such that for all points on the curve the sum of the two distances to the two fixed points (foci) is a constant  $2a$ . The complex equation of the ellipse is then  $|z - z_1| + |z - z_2| = 2a$ , where  $a > \frac{1}{2}|z_2 - z_1|$ . Write down the complex equation of the ellipse  $\frac{x^2}{25} + \frac{y^2}{9} = 1$ ;
- 6.2. Which set of points  $z$  in the complex plain is described by the inequality  $||z - z_1| - |z - z_2|| = 2a, a > 0$ .
7. Find  $\min|3 + 2i - z|$ , if  $|z| \leq 1$ .

## SAMPLE VARIANTS OF FINAL TEST

1. Write down the trigonometric and exponential representations of the given complex number.
2. Find  $|z|$  and  $\arg z$  of the complex number.
3. Do the computations. Write the result of computations in the algebraic form.
4. Find all values of the root.
5. Solve the equation.
6. Plot the set of points in the complex plain which satisfy the algebraic relations.

<p style="text-align: center;"><b>Variant 1</b></p> <ol style="list-style-type: none"> <li>1. <math>-1 - i\sqrt{3}</math>.</li> <li>2. <math>z = 4e^{-2i}</math>.</li> <li>3. <math>\frac{(-1 - i\sqrt{3})e^{i\frac{2\pi}{3}}}{\cos \frac{\pi}{4} + i \sin \frac{\pi}{4}}</math>.</li> <li>4. <math>\sqrt[3]{64i}</math>.</li> <li>5. <math>x^2 - 8x + 25 = 0</math>. a) <math>\operatorname{Im} z + 2 \geq \operatorname{Re}(z + 3)</math>;</li> <li>6. b) <math>z \cdot \bar{z} = \operatorname{Im}(2z)</math>.</li> </ol>	<p style="text-align: center;"><b>Variant 2</b></p> <ol style="list-style-type: none"> <li>1. <math>-\sqrt{3} - i</math>.</li> <li>2. <math>z = e^{3i}</math>.</li> <li>3. <math>\frac{(-\sqrt{3} - i)e^{i\frac{5\pi}{6}}}{\cos \frac{2\pi}{3} + i \sin \frac{2\pi}{3}}</math>.</li> <li>4. <math>\sqrt[3]{64}</math>.</li> <li>5. <math>x^2 + 8x + 25 = 0</math>. a) <math>\operatorname{Im}(z - 3i) - 2 \geq \operatorname{Re} z</math>;</li> <li>6. b) <math>z \cdot \bar{z} = \operatorname{Re}(4z)</math>.</li> </ol>
<p style="text-align: center;"><b>Variant 3</b></p> <ol style="list-style-type: none"> <li>1. <math>-\sqrt{3} + i</math>.</li> <li>2. <math>z = e^{-5i}</math>.</li> <li>3. <math>\frac{(-\sqrt{3} + i)e^{i\frac{\pi}{2}}}{\cos \frac{2\pi}{6} + i \sin \frac{2\pi}{6}}</math>.</li> </ol>	<p style="text-align: center;"><b>Variant 4</b></p> <ol style="list-style-type: none"> <li>1. <math>-1 + i\sqrt{3}</math>.</li> <li>2. <math>z = e^{4i}</math>.</li> <li>3. <math>\frac{(-1 + i\sqrt{3})e^{i\frac{2\pi}{3}}}{\cos \frac{\pi}{3} + i \sin \frac{\pi}{3}}</math>.</li> </ol>

<p>4. <math>\sqrt[3]{-8}</math>.</p> <p>5. <math>x^2 + 4x + 5 = 0</math>.</p> <p>a) <math>\text{Im}(z - i) &lt; 2 \text{Re } z + 5</math>;</p> <p>6. b) <math> z  + \text{Im } z = 4</math>.</p>	<p>4. <math>\sqrt[3]{27i}</math>.</p> <p>5. <math>x^2 - 2x + 4 = 0</math>.</p> <p>a) <math>\text{Im } \bar{z} \geq 2 - \text{Re}(z + 3)</math>;</p> <p>6. b) <math> z  + \text{Re } z = 2</math>.</p>
<p style="text-align: center;"><b>Variant 5</b></p> <p>1. <math>\sqrt{3} - i</math>.</p> <p>2. <math>z = 3e^{-3i}</math>.</p> <p>3. <math>\frac{(\sqrt{3} - i)e^{i\frac{\pi}{3}}}{\cos \frac{\pi}{6} + i \sin \frac{\pi}{6}}</math>.</p> <p>4. <math>\sqrt[3]{-27}</math>.</p> <p>5. <math>x^2 - 4x + 5 = 0</math>.</p> <p>a) <math>\text{Im } z \leq \text{Re}(\bar{z} - 1) + 2</math>;</p> <p>6. b) <math> z  - \text{Im } z = 1</math>.</p>	<p style="text-align: center;"><b>Variant 6</b></p> <p>1. <math>1 - i\sqrt{3}</math>.</p> <p>2. <math>z = 5e^{2i}</math>.</p> <p>3. <math>\frac{(1 - i\sqrt{3})e^{i\frac{2\pi}{3}}}{\cos \frac{\pi}{3} + i \sin \frac{\pi}{3}}</math>.</p> <p>4. <math>\sqrt[3]{8}</math>.</p> <p>5. <math>x^2 + 2x + 4 = 0</math>.</p> <p>a) <math>1 - \text{Im}(z + 2i) \geq \text{Re } z</math>;</p> <p>6. b) <math> z  - \text{Re } z = 1</math>.</p>
<p style="text-align: center;"><b>Variant 7</b></p> <p>1. <math>1 + i\sqrt{3}</math>.</p> <p>2. <math>z = 5e^{3i}</math>.</p> <p>3. <math>\frac{(1 - i\sqrt{3})e^{i\frac{2\pi}{3}}}{\cos \frac{\pi}{6} + i \sin \frac{\pi}{6}}</math>.</p> <p>4. <math>\sqrt[3]{125}</math>.</p> <p>5. <math>x^2 + 2x + 3 = 0</math>.</p> <p>a) <math>1 - \text{Im}(z - 2i) \geq \text{Re } z</math>;</p> <p>6. b) <math> z  - \text{Re } z = 2</math>.</p>	<p style="text-align: center;"><b>Variant 8</b></p> <p>1. <math>\sqrt{3} - i\sqrt{3}</math>.</p> <p>2. <math>z = 7e^{-2i}</math>.</p> <p>3. <math>\frac{(1 + i\sqrt{3})e^{i\frac{\pi}{3}}}{\cos \frac{\pi}{6} + i \sin \frac{\pi}{6}}</math>.</p> <p>4. <math>\sqrt[3]{-8i}</math>.</p> <p>5. <math>x^2 - 2x + 5 = 0</math>.</p> <p>a) <math>1 - \text{Im}(z + 3i) \geq \text{Re } z</math>;</p> <p>6. b) <math> z  - \text{Re}(2z) = 1</math>.</p>

<p style="text-align: center;"><b>Variant 9</b></p> <ol style="list-style-type: none"> <li>1. <math>\sqrt{3} + i\sqrt{3}</math>.</li> <li>2. <math>z = -2e^{-i}</math>.</li> <li>3. <math>\frac{(\sqrt{3} - i\sqrt{3})e^{i\frac{\pi}{4}}}{\cos\frac{\pi}{3} + i\sin\frac{\pi}{3}}</math>.</li> <li>4. <math>\sqrt[3]{125i}</math>.</li> <li>5. <math>x^2 + 2x + 2 = 0</math>.</li> <li>6. a) <math>2 - \operatorname{Im}(z + 3i) \geq \operatorname{Re} z</math>; b) <math> z - 1  + \operatorname{Re} z = 1</math>.</li> </ol>	<p style="text-align: center;"><b>Variant 10</b></p> <ol style="list-style-type: none"> <li>1. <math>2 - 2i\sqrt{3}</math>.</li> <li>2. <math>z = 4e^{-2i}</math>.</li> <li>3. <math>\frac{(1 - i\sqrt{3})e^{i\frac{\pi}{2}}}{\cos\frac{\pi}{4} + i\sin\frac{\pi}{4}}</math>.</li> <li>4. <math>\sqrt[3]{-64i}</math>.</li> <li>5. <math>x^2 - 2x + 2 = 0</math>.</li> <li>6. a) <math>1 - \operatorname{Im}(z + 5i) \geq \operatorname{Re}(2z)</math>; b) <math> z + i  - \operatorname{Im} z = 1</math>.</li> </ol>
<p style="text-align: center;"><b>Variant 11</b></p> <ol style="list-style-type: none"> <li>1. <math>2 - 2i</math>.</li> <li>2. <math>z = -3e^{3i}</math>.</li> <li>3. <math>\frac{(\sqrt{3} - i)e^{i\frac{\pi}{2}}}{\cos\frac{\pi}{2} + i\sin\frac{\pi}{2}}</math>.</li> <li>4. <math>\sqrt[3]{-27i}</math>.</li> <li>5. <math>x^2 + 4ix + 1 = 0</math>.</li> <li>6. a) <math>\operatorname{Im} z \leq \operatorname{Re}(\bar{z} - 2) + 1</math>; b) <math> z  - 2\operatorname{Im} z = 2</math>.</li> </ol>	<p style="text-align: center;"><b>Variant 12</b></p> <ol style="list-style-type: none"> <li>1. <math>2 + 2i</math>.</li> <li>2. <math>z = 8e^{\frac{2\pi}{3}i}</math>.</li> <li>3. <math>\frac{(1 - i\sqrt{3})e^{i\frac{4\pi}{3}}}{\cos\frac{3\pi}{4} + i\sin\frac{3\pi}{4}}</math>.</li> <li>4. <math>\sqrt[3]{-i}</math>.</li> <li>5. <math>x^2 + 2ix + 4 = 0</math>.</li> <li>6. a) <math>2 - \operatorname{Im}(z - i) \geq \operatorname{Re} z</math>; b) <math> z  - 2\operatorname{Re} z = 1</math>.</li> </ol>
<p style="text-align: center;"><b>Variant 13</b></p> <ol style="list-style-type: none"> <li>1. <math>-2 - 2i</math>.</li> <li>2. <math>z = 5e^{3i}</math>.</li> </ol>	<p style="text-align: center;"><b>Variant 14</b></p> <ol style="list-style-type: none"> <li>1. <math>-\sqrt{3} - i\sqrt{3}</math>.</li> <li>2. <math>z = 7e^{-2i}</math>.</li> </ol>

<p>3. <math>\frac{(-1+\sqrt{3})e^{i\frac{\pi}{3}}}{\cos\frac{5\pi}{6}+i\sin\frac{5\pi}{6}}</math>.</p> <p>4. <math>\sqrt[3]{-125i}</math>.</p> <p>5. <math>x^2+3x+9=0</math>.</p> <p>6. a) <math>1-\operatorname{Im}(z-i)\geq 2\operatorname{Re}z</math>; b) <math> z+2 -\operatorname{Re}z=2</math>.</p>	<p>3. <math>\frac{(\sqrt{3}+i)e^{i\frac{2\pi}{3}}}{\cos\frac{\pi}{2}+i\sin\frac{\pi}{2}}</math>.</p> <p>4. <math>\sqrt[3]{8i}</math>.</p> <p>5. <math>x^2-4ix-1=0</math>.</p> <p>6. a) <math>1-\operatorname{Im}(z-3i)\geq 3\operatorname{Re}z</math>; b) <math> z+3 -\operatorname{Re}z=3</math>.</p>
<p style="text-align: center;"><b>Variant 15</b></p> <p>1. <math>-4+4i</math>.</p> <p>2. <math>z=8e^{-4i}</math>.</p> <p>3. <math>\frac{(1-i)e^{i\frac{5\pi}{4}}}{\cos\frac{2\pi}{3}+i\sin\frac{2\pi}{3}}</math>.</p> <p>4. <math>\sqrt[3]{216i}</math>.</p> <p>5. <math>x^2+4x+16=0</math>.</p> <p>6. a) <math>2-\operatorname{Im}(z+5i)\geq 2\operatorname{Re}z</math>; b) <math> z-2 +\operatorname{Re}z=2</math>.</p>	<p style="text-align: center;"><b>Variant 16</b></p> <p>1. <math>4-4i</math>.</p> <p>2. <math>z=6e^{-\frac{\pi}{2}i}</math>.</p> <p>3. <math>\frac{(1+i)e^{i\frac{3\pi}{2}}}{\cos\frac{\pi}{3}+i\sin\frac{\pi}{3}}</math>.</p> <p>4. <math>\sqrt[3]{-216}</math>.</p> <p>5. <math>x^2-4x+6=0</math>.</p> <p>6. a) <math>1+\operatorname{Im}(z-3i)\geq \operatorname{Re}(3z)</math>; b) <math> z+2i -\operatorname{Im}z=2</math>.</p>

## EXAMPLE OF SOLUTION OF TEST VARIANT

**Task 1.** Write down the trigonometric and exponential representations of the given complex number

$$-1 - i\sqrt{3}.$$

*Solution:* the number  $z = -1 - i\sqrt{3}$  is given in algebraic form. To find its trigonometric representation we compute the modulus and argument of this number:

$$\operatorname{Re} z = x = -1, \operatorname{Im} z = y = -\sqrt{3},$$

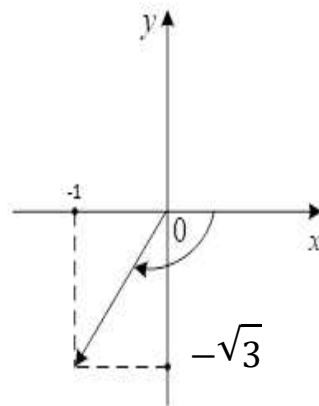


Fig. 3.27.

$$|z| = \sqrt{x^2 + y^2} = \sqrt{(-1)^2 + (-\sqrt{3})^2} = \sqrt{1+3} = \sqrt{4} = 2 \text{ (Fig. 3.20).}$$

$$\text{Hence, } \cos \varphi = -\frac{1}{2}, \sin \varphi = -\frac{\sqrt{3}}{2}.$$

Since  $x = -1 < 0$ ,  $y = -\sqrt{3} < 0$ , the point corresponding to the given complex number  $z$  lies in the 3-d quadrant of the complex plain and

$$\begin{aligned} \varphi = \arg z &= -\pi + \operatorname{arctg} \frac{y}{x} = -\pi + \operatorname{arctg} \frac{-1}{-\sqrt{3}} = \\ &= -\pi + \frac{\pi}{3} = \frac{-3\pi + \pi}{3} = -\frac{2}{3}\pi. \end{aligned}$$

Then,

$$z = -1 - i\sqrt{3} = 2\left(-\frac{1}{2} - \frac{\sqrt{3}}{2}i\right) = 2\left(\cos\left(-\frac{2\pi}{3}\right) + i\sin\left(-\frac{2\pi}{3}\right)\right).$$

Consequently, the trigonometric representation of the given complex number is

$$z = 2\left(\cos\left(-\frac{2\pi}{3}\right) + i\sin\left(-\frac{2\pi}{3}\right)\right).$$

The exponential representation is then  $z = 2e^{-\frac{2\pi}{3}i}$ .

*Answer:*  $z = 2\left(\cos\left(-\frac{2\pi}{3}\right) + i\sin\left(-\frac{2\pi}{3}\right)\right); z = 2e^{-\frac{2\pi}{3}i}$ .

**Task 2.** Find  $|z|$  and  $\arg z$  of the complex number  $z = 4e^{-2i}$ .

*Solution:* the exponential representation of a complex number is  $z = |z|e^{i\varphi}$ , where  $\varphi = \arg z$ . The complex number  $z = 4e^{-2i}$  is written in the exponential form, hence  $|z| = 4$ ,  $\arg z = -2$ .

*Answer:*  $|z| = 4$ ,  $\arg z = -2$ .

**Task 3.** Do the computations. Write the result of computations in the algebraic form:

$$\frac{(-1 - i\sqrt{3})e^{i\frac{2\pi}{3}}}{\cos\frac{\pi}{4} + i\sin\frac{\pi}{4}}.$$

*Solution:* denote

$$z_1 = -1 - i\sqrt{3}, z_2 = e^{i\frac{2\pi}{3}}, z_3 = \cos\frac{\pi}{4} + i\sin\frac{\pi}{4}.$$

Write the number  $z_1$  and  $z_2$  in the trigonometric form. The trigonometric representation of the number  $z_1$  is computed in Task 1:

$$z_1 = 2\left(\cos\left(-\frac{2\pi}{3}\right) + i\sin\left(-\frac{2\pi}{3}\right)\right),$$

$$z_2 = \cos \frac{2\pi}{3} + i \sin \frac{2\pi}{3}, \quad z_3 = \cos \frac{\pi}{4} + i \sin \frac{\pi}{4}.$$

When multiplying complex numbers written in the trigonometric form, we multiply their modules and their arguments:

$$\begin{aligned} z_1 \cdot z_2 &= 2 \left( \cos \left( -\frac{2\pi}{3} \right) + i \sin \left( -\frac{2\pi}{3} \right) \right) \cos \frac{2\pi}{3} + i \sin \frac{2\pi}{3} = \\ &= 2 \left( \cos \left( -\frac{2\pi}{3} + \frac{2\pi}{3} \right) + i \sin \left( -\frac{2\pi}{3} + \frac{2\pi}{3} \right) \right) = 2(\cos(0) + i \sin(0)). \end{aligned}$$

When dividing two complex numbers we divide their modules and subtract their arguments:

$$\begin{aligned} \frac{z_1 \cdot z_2}{z_3} &= \frac{2(\cos(0) + i \sin(0))}{\cos \frac{\pi}{4} + i \sin \frac{\pi}{4}} = 2 \left( \cos \left( -\frac{\pi}{4} \right) + i \sin \left( -\frac{\pi}{4} \right) \right) = \\ &= 2 \left( \frac{\sqrt{2}}{2} + i \frac{\sqrt{2}}{2} \right) = \sqrt{2} + i \sqrt{2}. \end{aligned}$$

$$\text{Answer: } \frac{(-1 - i\sqrt{3})e^{i\frac{2\pi}{3}}}{\cos \frac{\pi}{4} + i \sin \frac{\pi}{4}} = \sqrt{2} + i \sqrt{2}.$$

**Task 4.** Find all values of the root  $\sqrt[3]{64i}$ .

*Solution:* First we write the given complex number in the exponential form:

$$|64i| = |64| \cdot |i| = 64 \cdot 1 = 64, \quad \arg(64i) = \frac{\pi}{2}, \quad 64i = 64e^{i\frac{\pi}{2}}.$$

Then by Moivre's formula

$$\sqrt[3]{64i} = 64^{\frac{1}{3}} e^{i\frac{\pi}{6} + \frac{2i\pi k}{3}}, \quad k = 0, 1, 2.$$

$$k = 0: z_0 = 4e^{\frac{i\pi}{6}} = 4\left(\cos\frac{\pi}{6} + i\sin\frac{\pi}{6}\right) = 4\left(\frac{\sqrt{3}}{2} + i\frac{1}{2}\right) = 2\sqrt{3} + 2i;$$

$$k = 1: z_1 = 4e^{\frac{5i\pi}{6}} = 4\left(\cos\frac{5\pi}{6} + i\sin\frac{5\pi}{6}\right) = 4\left(-\frac{\sqrt{3}}{2} + i\frac{1}{2}\right) = -2\sqrt{3} + 2i;$$

$$k = 2: z_2 = 4e^{\frac{9i\pi}{6}} = 4e^{\frac{3i\pi}{2}} = 4\left(\cos\frac{3\pi}{2} + i\sin\frac{3\pi}{2}\right) = 4(0 - 1 \cdot i) = -4i.$$

*Answer:*  $z_0 = 2\sqrt{3} + 2i$ ,  $z_1 = -2\sqrt{3} + 2i$ ,  $z_2 = -4i$ .

**Task 5.** Solve the equation  $x^2 - 8x + 25 = 0$ .

*Solution:* for the given quadratic equation we have

$$a = 1, b = -8, c = 25,$$

Compute the discriminant of the equation:

$$D = b^2 - 4ac = (-8)^2 - 4 \cdot 1 \cdot 25 = 64 - 100 = -36;$$

$$\sqrt{D} = \sqrt{-36} = \pm 6i;$$

$$x_{1,2} = \frac{-b \pm \sqrt{D}}{2a}; x_1 = \frac{8 + 6i}{2} = 4 + 3i; x_2 = \frac{8 - 6i}{2} = 4 - 3i.$$

*Answer:*  $4 + 3i$ ;  $4 - 3i$ .

**Task 6.** Plot the set of points in the complex plain which satisfy the algebraic relations:

$$1) \operatorname{Im} z + 2 \geq \operatorname{Re}(z + 3);$$

$$2) z \cdot \bar{z} = \operatorname{Im}(2z).$$

*Solution:*

1)  $\operatorname{Im} z + 2 \geq \operatorname{Re}(z + 3)$ . Substituting  $z = x + iy$  in left- and right-hand sides of the inequality we get

$$\operatorname{Im} z + 2 = y + 2; \operatorname{Re}(z + 3) = \operatorname{Re}(x + iy + 3) = x + 3.$$

Then the inequality becomes  $y + 2 \geq x + 3$ , hence,  $y \geq x + 1$ .

First let us plot the points in the complex plain satisfying the equality  $y = x + 1$ . The equality determines a line through the points  $(0,1), (-1,0)$ . The line divides the plane in two half-planes. The sign of the inequality is the same for all points from a half-plane. In order to determine in which half-plane the inequality  $y > x + 1$  holds, we substitute the coordinates of a point which is not on the line, into the inequality. We opt for the origin:  $x = 0, y = 0$ . This point lies below the straight line in the complex plain. Since the inequality  $0 \geq 0 + 1$  is not true, the point  $(0,0)$  is not in the required domain. Thus, we conclude, that the required domain consists of the upper (with respect to the line  $y = x + 1$ ) half-plain of the complex plain and the line itself.

2)  $z \cdot \bar{z} = \text{Im}(2z)$ . We substitute  $z = x + iy$  in the equality:

$$z \cdot \bar{z} = (x + iy)(x - iy) = x^2 + y^2, \quad \text{Im}(2z) = \text{Im}(2x + 2iy) = 2y,$$

to get  $x^2 + y^2 = 2y$ . We rearrange the terms in the equality to separate the perfect square in  $y$ :

$$x^2 + y^2 - 2y = 0; \quad x^2 + y^2 - 2y + 1 = 1; \quad x^2 + (y - 1)^2 = 1.$$

Thus, we arrive at the equation of the circle of radius  $R = 1$  centered at the point  $x = 0, y = 1$ .

*Answer:* 1) The required domain consists of the upper with respect to the line  $y = x + 1$  half-plain of the complex plain and the line itself (Fig. 3.21).

2) The required domain is the circle of radius  $R = 1$  centered at the point  $x = 0, y = 1$  (Fig. 3.22).

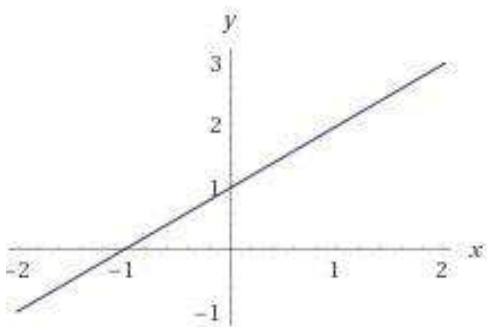


Fig. 3.28.

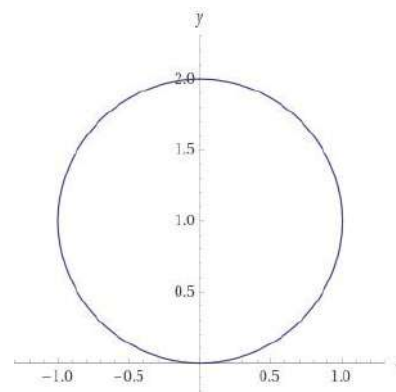


Fig. 3.29.

## REFERENCES

1. Ahlfors L. *Complex analysis*. N.J., Kluver, 1981. – 317 p.
2. Greene R. E., Krantz S. G. *Function Theory of One Complex Variable*. John Wiley & Sons, Inc. New York, 2nd Ed. 2002, 493 p.
3. Ablowitz M. J., Fokas A. S. *Complex Variables: Introduction and Applications*. Cambridge, 2003.
4. Complex Number – Wikipedia”. 2022. Internet access: [en.wikipedia.org](https://en.wikipedia.org/wiki/Complex_number).  
[https://en.wikipedia.org/wiki/Complex\\_number](https://en.wikipedia.org/wiki/Complex_number).
5. Pathak H.P., Agarwal R. P., Cho Y. J. *Functions of a Complex Variable*. CRC Press, 1st Ed. 2015, 742 p.
6. Pavlova L. V. Teoriya analitychnykh funktsiy. Zbirnyk vprav: navch. posib. / L. V. Pavlova, O. I. Red'kina. – K. : Vyshcha shkola, 1980. – 216 p.
7. Hryshchenko, O. Yu. Teoriya funktsiy kompleksnoyi zminnoyi: rozv'yazuvannya zadach / O. Yu. Hryshchenko, M. I. Nahnybida, P. P. Nastasiyev. – K.: Vyshcha shk., 1994. – 335 p.
8. Hol'berh A. A., Sheremeta M. M., Zabolots'kyi M. V., Skaskiv O.B. *Kompleksnyy analiz [Complex analysis]*. L'viv, Afisha, 2002.– 242p.
9. Krayevs'kyi V.O. *Funktsiyi kompleksnoyi zminnoyi [Function of complex variable]*. Vinnytsya, Vyd-vo Vinnyts'koho un-tu, 2013. – 142 p.
10. Kompleksni chysla, zobrazhennya kryvykh ta oblastey na kompleksniy ploschyni/ Metodychni vказivky dlya samostiynoyi roboty z kursu «Vyshcha matematika» dlya studentiv inzhenernykh spetsial'nostey / uklad. S.D. Dimitrova, N.P. Hyrya, V.M.Burlyayenko – Kharkiv: NTU «KHPI», 2022. – 56 p. – Ukr. movoyu. Internet access: <https://repository.kpi.kharkov.ua/handle/KhPI-Press/61851>

# CONTENT

<b>INTRODUCTION</b> .....	3
<b>1.Set of complex numbers</b> .....	8
<b>1.1. Questions for self-control 1</b> .....	18
<b>1.2. Test 1</b> .....	19
<b>1.3. Tasks for individual work 1</b> .....	23
<b>2.Operations with complex numbers</b> .....	24
<b>2.1. Questions for self-control 2</b> .....	44
<b>2.2. Test 2</b> .....	45
<b>2.3. Tasks for individual work 2</b> .....	46
<b>3.Domains and curves in complex plain</b> .....	51
<b>3.1. Questions for self-control 3</b> .....	66
<b>3.2. Test 3</b> .....	67
<b>3.3. Tasks for individual work 3</b> .....	69
<b>4.Sample variants of final test</b> .....	71
<b>5.Example of solution of test variant</b> .....	75
<b>REFERENCES</b> .....	80

Навчальне видання

ДІМІТРОВА Світлана Дімова  
ГИРЯ Наталія Петрівна  
БУРЛАСНКО В'ячеслав Миколайович  
НАБОКА Олена Олексіївна

КОМПЛЕКСНІ ЧИСЛА ТА ЇХ ЗАСТОСУВАННЯ ДЛЯ  
ПРЕДСТАВЛЕННЯ КРИВИХ І ОБЛАСТЕЙ НА КОМПЛЕКСНІЙ  
ПЛОЩИНІ

Навчально-методичний посібник  
для самостійної роботи студентів технічних спеціальностей  
усіх форм навчання

Англійською мовою

Відповідальний за випуск проф. Юлія ПЕРШІНА  
Роботу до видання рекомендував проф. Наталія ЧІКІНА

В авторській редакції

План 2024 р., поз. 3

Підп. до друку 12. 03. 2024 р.  
Гарнітура Times New Roman.

---

Видавничий центр НТУ «ХПІ».  
Свідоцтво про державну реєстрацію ДК № 5478 від 21.08.2017 р.  
61002, Харків, вул. Кирпичова, 2

---

Електронне видання