

## THE STRUCTURE OF VIRTUAL PROMOTION MAP

Orekhov S.V., Mehdi Masmar  
*National Technical University*  
*«Kharkiv Polytechnic Institute», Kharkiv*

The results of the research, which are reflected in the works [1-2], prove the need to introduce a new research object named virtual promotion map. The map describes the distribution of advertising about the product on the Internet. The structure of the map resembles a two-level system. The nodes of the map are Internet nodes such as marketplaces, social networks, corporate WEB sites, video services, and so on. On the first level there is a WEB site of a company that promotes a given product on the Internet. The root of the map is called the alliance of product advertising providers. The rest of the nodes are providers of an advertisement about our product. It is shown in Figure 1.

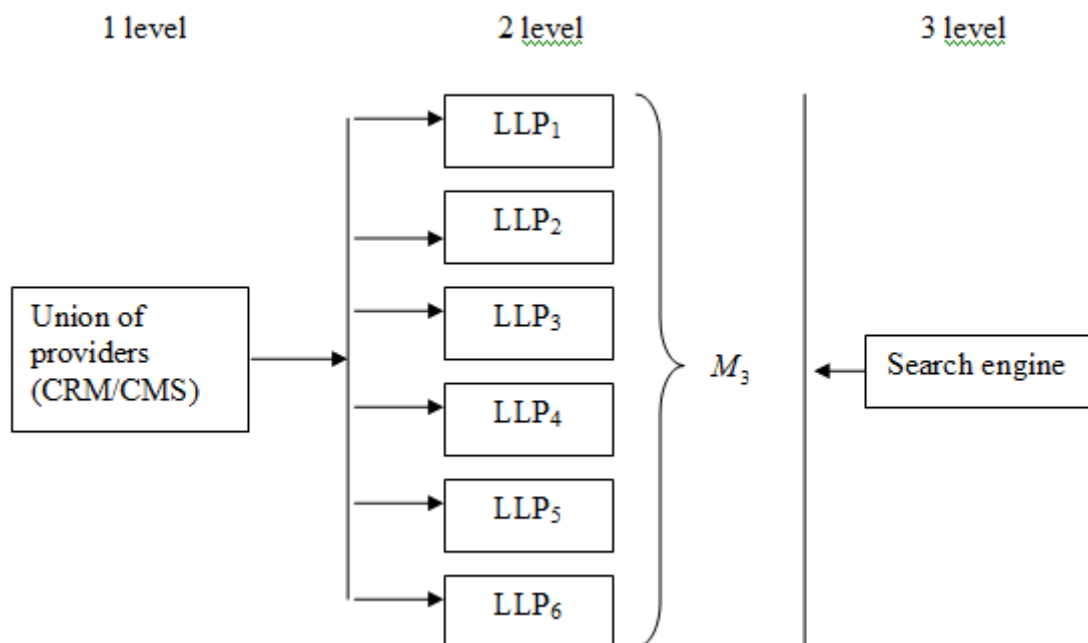

Figure 1 – Sample of the map

Figure 1 shows an example of a real map showing a union of providers with six elements. Such a card was used to promote the goods of one of the companies in the city of Kharkov. It was the introduction of the card that allowed this company to receive the first online orders within ten days. Although before that for three months the use of Google advertising did not give a single order.

### References:

1. Orekhov S., Kopp A., Orlovskiy D. Example of use of virtual promotion map. / S. Orekhov, A. Kopp, D. Orlovskiy. // Вісник Національного технічного університету «ХПІ». Серія: Системний аналіз, управління та інформаційні технології. Збірник наукових праць. Харків: НТУ «ХПІ», 2022. – № 2(8). – С. 70–74.
2. Kopp A., Dmytro Orlovskiy D., Orekhov S. Map of Virtual Promotion of a Product. // Advances in Intelligent Systems, Computer Science and Digital Economics III. Switzerland: Springer Nature, 2022. - Volume 121. - P. 81-91.