

**YAKOVENKO I.E., PERMYAKOV A.A., KHARCHENKO O.S.**

## **DEVELOPMENT OF THE COMPONENT BASE OF UNIFIED ASSEMBLY AND PARTS OF INSTALLATION CLAMPING DEVICES**

The issues of unification of units and elements of special equipment were further developed in the work. Issues of a theoretical approach to the creation of an element base of unified assemblies and parts for existing layout schemes for mounting and clamping devices of equipment built on the principles of aggregation are considered. In order to subsequently minimize the cost of design and production. The authors propose a two-stage methodology for unifying fixture elements in order to create a reference and regulatory framework for such elements. At the first stage, based on the analysis of the functional purpose of the structural elements of various layout schemes of devices, a list of parts is established, the unification of which is possible and expedient. At the second stage, based on the strength analysis of the selected elements and the analysis of statistical information on the geometric parameters of the installed workpieces for various layout schemes of fixtures, the number of standard sizes and geometric parameters of these parts are determined. This approach allows you to create a constantly updated and edited database of unified fixture elements, which can be used in the process of computer-aided design.

**Keywords:** aggregated equipment, mounting fixture, unification, layout, strength analysis, elements, standard size

**ЯКОВЕНКО І.Є., ПЕРМЯКОВ О.А., ХАРЧЕНКО О.С.**

## **РОЗРОБКА ЕЛЕМЕНТНОЇ БАЗИ УНІФІКОВАНИХ ВУЗЛІВ І ДЕТАЛЕЙ УСТАНОВКОВО ЗАТИСКОВИХ ВИКОРИСТАНЬ**

У роботі отримали подальший розвиток питання уніфікації вузлів та елементів спеціального обладнання. Розглянуто питання теоретичного підходу до створення елементної бази уніфікованих вузлів та деталей для існуючих компоновальних схем настановно затискних пристроїв обладнання, побудованого на принципах агрегування, з метою подальшої мінімізації витрат на проектування та виробництво. Авторами пропонується двоетапна методика проведення уніфікації елементів пристроїв з метою створення довідково-нормативної бази таких елементів. На першому етапі на підставі аналізу функціонального призначення структурних елементів різних компоновочних схем пристроїв встановлюється перелік деталей, уніфікація яких можлива та доцільна. На другому етапі на підставі аналізу міцності обраних елементів і аналізу статистичної інформації за геометричними параметрами встановлюваних заготовок для різних компоновочних схем пристосувань встановлюється кількість типорозмірів і геометричні параметри цих деталей. Такий підхід дозволяє створити постійно поповнювану та редаговану базу уніфікованих елементів пристроїв, яка може бути використана у процесі автоматизованого проектування.

**Ключові слова:** агрегатоване обладнання, установочно-затискний пристрій, уніфікація, компоновка, аналіз міцності, елементи, типорозмір

**ЯКОВЕНКО И.Э., ПЕРМЯКОВ А.А., ХАРЧЕНКО А.С.**

## **РАЗРАБОТКА ЭЛЕМЕНТНОЙ БАЗЫ УНИФИЦИРОВАННЫХ УЗЛОВ И ДЕТАЛЕЙ УСТАНОВОЧНО ЗАЖИМНЫХ ПРИСПОСОБЛЕНИЙ**

В работе получили дальнейшее развитие вопросы унификации узлов и элементов специального оборудования. Рассмотрены вопросы теоретического подхода к созданию элементной базы унифицированных узлов и деталей для существующих компоновочных схем установочно зажимных приспособлений оборудования, построенного на принципах агрегатирования, с целью последующей минимизации затрат на проектирование и производство. Авторами предлагается двухэтапная методика проведения унификации элементов приспособлений с целью создания справочно-нормативной базы таких элементов. На первом этапе на основании анализа функционального назначения структурных элементов различных компоновочных схем приспособлений устанавливается перечень деталей, унификация которых возможна и целесообразна. На втором этапе на основании прочностного анализа выбранных элементов и анализа статистической информации по геометрическим параметрам устанавливаемых заготовок для различных компоновочных схем приспособлений устанавливается количество типоразмеров и геометрические параметры этих деталей. Такой подход позволяет создать постоянно пополняемую и редактируемую базу унифицированных элементов приспособлений, которая может быть использована в процессе автоматизированного проектирования.

**Ключевые слова:** агрегированное оборудование, установочно зажимное приспособление, унификация, компоновка, прочностной анализ, элементы, типоразмер

**Introduction.** One of the ways to increase the efficiency of technological preparation of production is to increase the level of use of standardized equipment and, first of all, machine tools, taking into account the subsequent specialization of production. This is especially true when using special equipment, which is created on the principles of aggregation. In this case, as a result of unification and standardization, designs are created that correspond to the most complete and efficient use of high-performance equipment, as well as designs that provide the minimum time for design and technological preparation for the production of equipment of this type, due to the use of CAD/CAM systems in the design process.

**Analysis of the main achievements and literature.** In research [1, 2] the issues of increasing the level of unification of machine tools are considered, a generalized criterion is given that can be used as the basis for the development of unified machine tools. The criterion is a typical installation diagram for machine tools. However, the implementation of work on the unification of machine tools in full should solve not only the issues of unification of basic devices, but also individual structural elements. In [1], the concept of unification is opposed to the mathematical concept of "sets". The description of unification processes by the methods of mathematical set theory makes it possible to clearly formulate a number of basic provisions and develop a calculation apparatus for solving practical problems of unification of machine tools. In papers [3],

a method for selecting machine fixtures based on classifiers of parts and assemblies is described, which can be used at the stage of designing the design of fixtures. However, part classifiers based on the principle of naming (cases, bushings, etc.) do not give a clear idea of the setting elements that should be used when orienting workpieces.

In papers [4,5], the unification of positioning clamping fixture (PCF) for processing the same type of parts of hydraulic fittings on multi-position modular machines was carried out, but there are no general recommendations for creating devices for processing parts of other classes. The papers [6, 7] consider the general issues of creating unified layout diagrams of PCF for specialized equipment, which is built on the principles of aggregation in order to subsequently minimize the costs of their design and production. The unification of layout schemes is based on the analysis of the designs of existing mounting fixtures, as well as the functional purpose of the structural elements and parts of the main fixture systems. However, the unification of individual elements and parts of the mechanisms of the considered layout schemes was not carried out. The article [8] describes a fixture design method based on the analysis of the power characteristics of the machining process and minimizes the deflection of the object under the action of external loads, this approach in the future makes it possible to develop parametric series of unified parts and elements of the PCF.

The works [9,10] laid the foundations for automating the design of fixtures for metal-cutting machine tools, which made it possible to create a number of real software systems. However, specific elements of the unification of structures were not covered. Further development of the principles of automation of various stages of fixture design (Computer-aided fixture design, CAFD-system) and analysis of the design decisions made are considered in [11-14]. So, in [12], a process-oriented model of the fixture design process was developed, which provides analysis of the workpiece manufacturing, synthesis and optimization of the fixture configuration, verification of the mechanical system "device - product" for given production conditions, functional relationships, and data flows between stages are determined, which allows implement an integrated approach to automated tooling design in multi-product production.

On the basis of the proposed conceptual solutions, in papers [15] specific issues of choosing the installation elements of the basing as a stage in the design of the layout of machine tools for a specific type of parts and the layout of the device are considered. Based on the developed algorithm, a reasonable choice of setting elements for blanks of body parts is implemented when implementing the basing scheme in three planes. The sequence of formation of a set of solutions is given when choosing the functional elements of a machine tool from the database, taking into account the design and technological characteristics of the workpiece.

**The purpose of the study, statement of the problem.** The aim of the study is the classification and subsequent unification of elements and parts of aggregated equipment fixtures for the implementation of an automated approach to the design process, increasing the serial production and possible readjustment of the PCF.

To achieve this goal, it is necessary:

- on the basis of the classification of layout diagrams of the PCF of aggregated equipment, perform the unification of the element base;
- to develop a set of standardized parts and assemblies that implement typical layout diagrams of PCF, the use of which reduces the complexity of design and manufacture, and also allows re-arrangement when changing processing objects.

**Research materials.** The unification of machine tools applies to types, designs, main dimensions and parameters of devices, their components, as well as materials, accuracy standards, etc. Unifications are subject to:

- parts of fixtures that have a specific functional purpose and have similar dimensions (body plates, clamping collets, annular and horn membranes, cassettes for multiple milling fixtures);
- assembly elements (assemblies) that perform functions of the same nature with slightly different working dimensions and dimensions (built-in double-acting pneumatic cylinders, pneumatic-hydraulic amplifiers, eccentric clamping mechanisms acting on two clamps, dividing mechanisms, etc.);
- fixtures for equipping typical operations, if their designs are similar to schemes, dimensions, operating conditions.

Unified designs of parts and assembly units should ensure optimal repeatability in fixtures or in arrangements of several parts, and unified fixtures should equip the optimal number of operations. Unified elements must have unified base and connecting places with a range of sizes from the required parametric range.

The structural layout schemes considered in [7] made it possible to identify the main units and elements of the PCF, which are characteristic of absolutely all layout options. These include:

- housing elements ( housings with various additional and connecting elements for basing and fixing the rest of the PCF units);
- power unit (drive);
- elements of workpiece basing and auxiliary devices;
- clamping unit.

As the analysis of the PCF layout solutions has shown, for each of the considered layout schemes, its own set of details is correct.

The elements of the PCF case are mostly original. As shown by the analysis of the layout diagrams of the housings, that the actually unified element of the housing is the sole, the dimensions of which are regulated and determined by the diameter of the faceplate and the number of positions of the rotary dividing table. The design and geometrical parameters of the housing are directly determined by the parameters of the workpiece, the layout of the device, the type of functional elements and their relative position.

The energy unit is practically independent of the adopted layout scheme, since in most cases unified hydraulic or pneumatic drives are used. Only in some cases, to minimize the dimensions of the device, original body designs and unified elements of the rod and piston group are used. Therefore, for the elements of this assembly, the unification was carried out on the basis of the normalized size ranges of the drive elements, depending on the need to provide the required clamping force, without the use of additional studies.

The locating node is determined primarily by the technological locating scheme and the geometric parameters of the workpiece. When considering the layout schemes, almost all typical basing schemes were considered using mounting pins, conventional and self-centering prisms, strips, etc. All these elements have a clear functional purpose and design elements. In the general case, the surfaces that are in contact with the workpiece are original, so the unification was carried out only in relation to the design of the base element, and the geometric parameters are determined depending on the parameters of the workpiece and the layout of the device. The exception is the special elements for basing jig devices, which are implemented in the form of two standard pins: cylindrical (Fig. 1a) and rhombic (Fig. 1b).

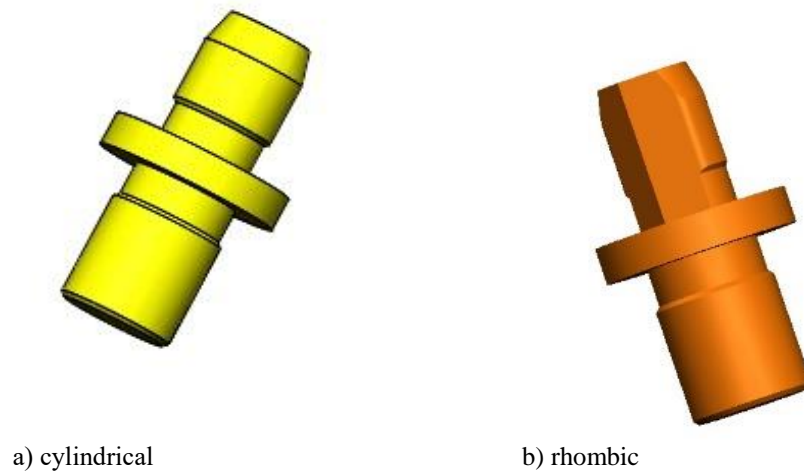

Fig.1 – Positioning pins

Particular attention during the unification was paid to the clamp assembly, as the most specified element of the fixture. Despite the variety of options for layout schemes and their parametric implementation, for each option it is possible to establish a clear list of details and elements that provide the technical implementation of the selected scheme. All considered elements perform well-defined functional tasks, have a certain kinematics of movement and, accordingly, design features, therefore, they can be considered as elements of unification.

In the process of research for each layout scheme of the USP at the first stage, using the simplification method, the authors established the necessary and sufficient list of parts that implement the corresponding scheme (Figure 2 shows an example of detailing the direct-action clamping mechanism with a lever-type clamp for further unification, similarly, and other options, such as a clamping mechanism with a traverse). As the analysis showed, part of the details (25-35% depending on the layout scheme of the PCF) are standard and do not require unification, but are included in the assembly specification in the section of standard elements.

At the second stage, a 3D model of the mechanism is created and a strength analysis of the mechanism is carried out in order to identify the main most loaded element, which determines the strength of the entire structure and is the basis for determining the parametric characteristics of this element itself and the assembly parts mating with it. In the example (Fig. 3), the limiting element is a groove on the thrust shaft, while the proposed diameter provides a 3-fold margin of safety of the element, which is sufficient for such a mechanical design. Using the range of realizable loads, taking into account the necessary margin of safety, as well as the value of the working stroke of the main element for the layout scheme under consideration, a parametric series of geometric dimensions of the element and, accordingly, the parts mating with it, is formed. The basis for the formation of parametric series are tables of preferred sizes.

Subsequently, elements and parts of the same type of design and the same functional purpose were identified for various layout schemes and mechanisms, and parametric series were adjusted for unified parts.

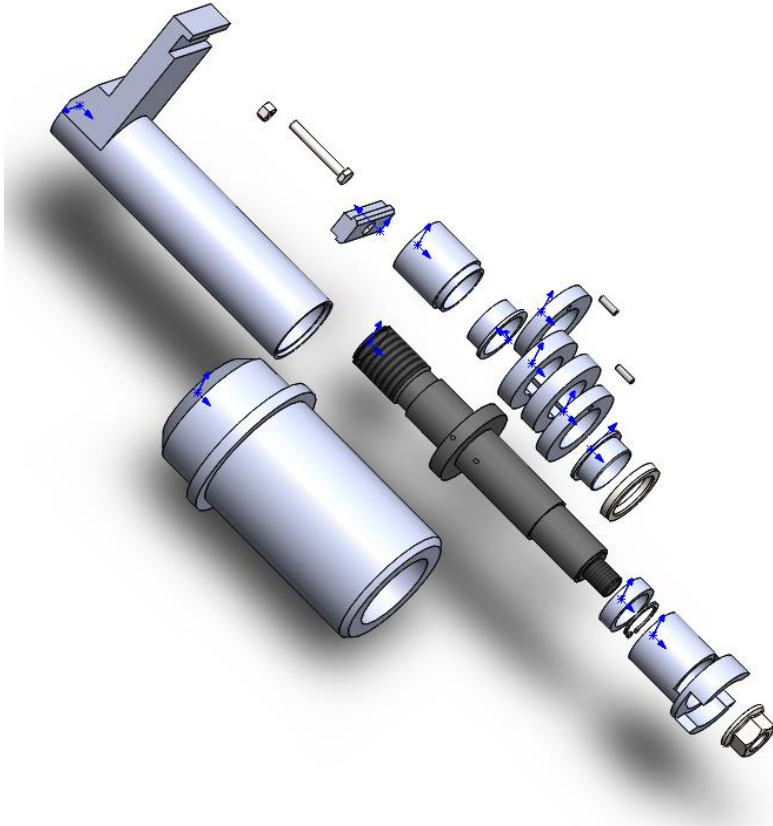

Fig. 2 – Tack elements subject to unification

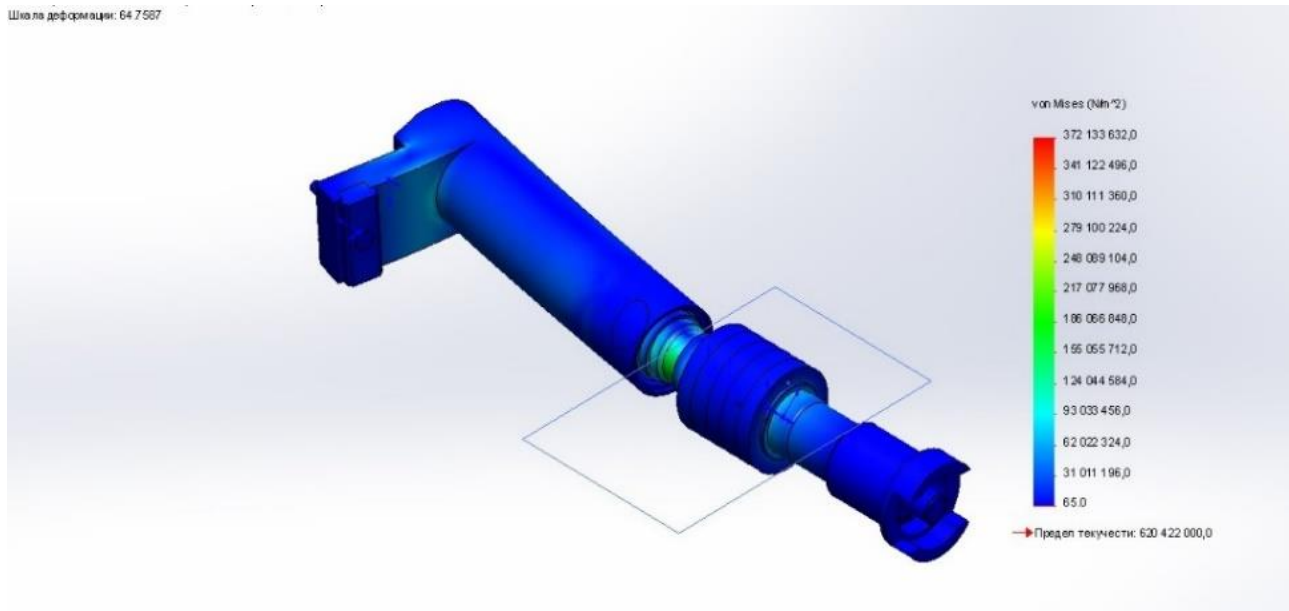

Fig. 3 – Load diagram of the clamping mechanism to adapt the layout scheme of direct action

This approach made it possible to create a database of 3D models of unified elements and parts for ultrasonic devices of equipment, which is built according to the aggregate principle (a fragment for the above example of the ultrasonic device layout diagram is shown in Table 1).

Table 1 – A set of standard PCF elements for a structural layout diagram of direct action

Element	Element	Element
 Bolt Standard element ISO 4014	 Screw Standard element GOST 11644-75	 Nut Standard element ISO 4034
 Retaining Ring Standard element GOST 13942-86	 Pin Standard element GOST 3129-70	 Cuff Standard element GOST 678-72
 Sleeve Unified element 6 Size	 Bronze Sleeve Unified element 6 Size	 Special Nut Unified element 6 Size
 Spacer Sleeve Unified element 6 Size	 Ring Unified element 2 Size	 Double Ring Unified element 6 Size
 Hole Ring Unified element 3 Size	 Hull Unified element 6 Size	 Half-coupling Unified element 6 Size
 Tack Unified element 6 Size	 Rod Unified element 2 Size	 Strip Unified element 1 Size

**Conclusion.** On the basis of the conducted research of the layout diagrams of the PCF for aggregated equipment, a method for unifying the elements and parts of the main units has been developed. The proposed method takes into account the functional purpose of parts and elements when choosing a structure, and the assignment of parametric characteristics of geometric dimensions is performed on the basis of a strength analysis of the structure's operability and general engineering recommendations of preferred sizes.

The proposed technique was implemented when creating a database of unified parts of the PCF for aggregated equipment. The developed database was the information support for automating the design process of the PCF, which made it possible to select and maximize the use of unified elements of the assembly kit in the development of the device.

The method proposed by the authors allows expanding and correcting the base of unified devices when considering new layout diagrams of the PCF both for modular machines and for other equipment that uses the principles of unification and aggregation.

**Список литературы:**

1. Кузнецов Ю.Н. Унификация и стандартизация станочных приспособлений. Основные требования. – М.: Изд.стандартов, 1976. – 100 с.
2. Методика унификации и стандартизации станочных приспособлений. Основные требования. – М.: Изд.стандартов, 1976. – 100 с.
3. Соколов Е.В. Выбор станочных приспособлений на основе классификаторов деталей и оснастки. – М.: Машиностроение, 1986. – 43 с.
4. Пермяков А.А., Яковенко И.Э., Фадеев А.В. О моделировании компоновок УЗП многопозиционных агрегатных станков //Вісник Національного технічного університету «ХПІ». – Харків: НТУ «ХПІ». – 2003. - №6. – С.148-152.

5. *Пермяков А.А., Тимофеев Ю.В., Яковенко И.Э.* Оптимизация проектирования и производства УЗП на основе унификации компоновочных решений. //Вестник ХГПУ. - Харьков:ХГПУ. - 2000. - Вып.110. - С.70-74.
6. *М.А. Терехов, И.Э. Яковенко.* К вопросу унификации установочно – зажимных приспособлений в серийном производстве.// VIII Університетська науково-практична студентська конференція магістрантів Національного технічного університету «Харківський політехнічний інститут» (22–24 квітня 2014 року: матеріали конференції: у 3-х ч. – Ч. 1 / оргкомітет: Л.Л. Товажнянський (голова) та ін. – Харків : НТУ «ХПІ», 2014.
7. *Пермяков А.А., Яковенко И.Э.* К вопросу об унификации установочно зажимных приспособлений агрегатированного оборудования //Вісник Національного технічного університету «ХПІ». Збірник наукових праць. Серія: Технології в машинобудуванні. – Х. : НТУ «ХПІ». – 2016. – № 33 (1205). – 166 с. –с.38-43.
8. *Q. Lin, J. W. Burdick, E. Rimon* (Member IEEE) Constructing Minimum Deflection Fixture Arrangements Using Frame Invariant Norms. //IEEE TRANSACTIONS ON AUTOMATION SCIENCE AND ENGINEERING, VOL. 3, NO. 3, JULY 2006, pp.272-286.
9. *Ракович А.Г.* Автоматизация проектирования технологической оснастки. – Киев, 1987. – 135 с.
10. *Ракович А.Г.* Основы автоматизации проектирования технологических приспособлений / Под ред. Е.А.Стародетко.- Мн.: Наука и техника, 1985.- 285 с..
11. *Wang H., Rong Y., Li H., Price S.* Computer-aided fixture design: recent research and trends. J. Comp.-Aided Des. 42 (12), 1085-1094 (2010).
12. *Ivanov V.* Process-oriented approach to fixture design /Advances in Design, Simulation and Manufacturing: Proceedings of the International Conference on Design, Simulation, Manufacturing: The Innovation Exchange, DSMIE-2018, June 12-15, 2018, Sumy, Ukraine. pp.42-49.
13. *Іванов В.О.* Структурно-функціональне моделювання процесу проектування верстатних пристроїв. / В.О. Іванов, В.Є. Карпусь, С.М. Ващенко, Й. Заяць, А.І. Кармаза// Вісник НТУ «ХПІ». Серія Технології в машинобудуванні. – Х.:НТУ «ХПІ», 2017. -№ 17 (1239). С. 30-37.
14. *Ivanov V., Vaschenko S., Rong Y.* Information of the Computer Aided Fixture Design System. Proc of 12<sup>th</sup> Int.Conf ICTERI'2016, Kyiv, Ukraine, June 21-24, 2016, CEUR-WS.org, /Vol-1614, pp.73-86.
15. *В.О. Іванов , В.О. Залоза , Є.В. Басова , В.С. Капанайко.* Алгоритм вибору установлювальних елементів верстатних пристроїв. //Міжвузівський збірник "НАУКОВІ НОТАТКИ". Луцьк, 2018. Випуск № 64, с. 65-72.

#### Bibliography (transliterated):

1. *Kuznetsov YU.N.* Unifikatsiya i standartizatsiya stanochnykh prispособlenij. Osnovnye trebovaniya. – М.: Izd.standartov, 1976. – 100 s.
2. *Metodika unifikatsii i standartizatsii stanochnykh prispособlenij. Osnovnye trebovaniya.* – М.: Izd.standartov, 1976. – 100 s.
3. *Sokolov E.V.* Vybory stanochnykh prispособlenij na osnove klassifikatorov detalej i osnastki. – М.: Mashinostroenie, 1986. – 43 s.
4. *Permyakov A.A., Yakovenko I.E., Fadeev A.V.* O modelirovanii komponovok UZP mnogopozitsionnykh agregatnykh stankov //Vіsник Nacional'nogo tekhnicheskogo universiteta «KHPІ». – Kharkiv: NTU «KHPІ». – 2003. - №6. – S.148-152.
5. *Permyakov A.A., Timofeev YU.V., Yakovenko I.E.* Optimizatsiya proektirovaniya i proizvodstva UZP na osnove unifikatsii komponovochnykh reshenij. // Vestnik KHGPU. - Khar'kov: KHGPU. - 2000. - Vyp.110. - S.70-74.
6. *М.А. Терехов, И.Э. Яковенко.* К вопросу унификации установочно – зажимных приспособлений в серийном производстве.// VIII Університетська науково-практична студентська конференція магістрантів Національного технічного університету «Харківський політехнічний інститут» (22–24 квітня 2014 року: матеріали конференції: у 3-х ч. – Ч. 1 / оргкомітет: Л.Л. Товажнянський (голова) та ін. – Харків : НТУ «ХПІ», 2014.
7. *Permyakov A.A., Yakovenko I.E.* К вопросу об унификации установочно зажимных приспособлений агрегатированного оборудования //Вісник Nacional'nogo tekhnicheskogo universiteta «KHPІ». Zbirnik naukovikh prac'. Seriya: Tekhnologii v mashinobuduvanni. – KH. : NTU «KHPІ». – 2016. – № 33 (1205). – 166 s. –с.38-43.
8. *Q. Lin, J. W. Burdick, E. Rimon* (Member IEEE) Constructing Minimum Deflection Fixture Arrangements Using Frame Invariant Norms. // IEEE TRANSACTIONS ON AUTOMATION SCIENCE AND ENGINEERING, VOL. 3, NO. 3, JULY 2006, pp.272-286.
9. *Rakovich A.G.* Avtomatizatsiya proektirovaniya tekhnologicheskoy osnastki. – Kiev, 1987. – 135 s.
10. *Rakovich A.G.* Osnovy avtomatizatsii proektirovaniya tekhnologicheskikh prispособlenij / Pod red. E.A.Starodetko.- Мн.: Наука і техніка, 1985.- 285 с..
11. *Wang H., Rong Y., Li H., Price S.* Computer-aided fixture design: recent research and trends. J. Comp.-Aided Des. 42 (12), 1085-1094 (2010).
12. *Ivanov V.* Process-oriented approach to fixture design /Advances in Design, Simulation and Manufacturing: Proceedings of the International Conference on Design, Simulation, Manufacturing: The Innovation Exchange, DSMIE-2018, June 12-15, 2018, Sumy, Ukraine. pp.42-49.
13. *Іванов В.О.* Структурно-функціональне моделювання процесу проектування верстатних пристроїв. / В.О. Іванов, В.Є. Карпус', С.М. Ващенко, І. Заяць, А.І. Кармаза// Вісник НТУ «ХПІ». Серія Технології в машинобудуванні. – Х.:НТУ «ХПІ», 2017. -№ 17 (1239). С. 30-37.
14. *Ivanov V., Vaschenko S., Rong Y.* Information of the Computer Aided Fixture Design System. Proc of 12<sup>th</sup> Int.Conf ICTERI'2016, Kyiv, Ukraine, June 21-24, 2016, CEUR-WS.org, /Vol-1614, pp.73-86.
15. *V.O. Ivanov, V.O. Zalozha , E.V. Basova , V.S. Kapanaiko.* Algoritm voboru ustanovlyval'nikh elementiv verstatnikh pristroiv. //Mizhvuziv'skij zbimik "NAUKOVI NOTATKI". Luc'k, 2018. Vipusk № 64, s. 65-72.

*Поступила (received) 15.03.2022*

#### *Відомості про авторів / Сведения об авторах / About the Authors*

**Яковенко Ігор Едуардович (Яковенко Игорь Эдуардович, Yakovenko Ihor Eduardovich)** – кандидат технічних наук, професор кафедри "Технологія машинобудування та металорізальні верстати" Національного Технічного Університету «Харківський політехнічний інститут», м. Харків; тел.: +38 (057) 707-66-34; e-mail: [igor.dych59@gmail.com](mailto:igor.dych59@gmail.com), <https://orcid.org/0000-0001-8344-996X>

**Пермяков Олександр Анатолійович (Пермяков Александр Анатольевич, Permyakov Alexandr Anatolievich)** – доктор технічних наук, професор, завідувач кафедри "Технологія машинобудування та металорізальні верстати" Національного Технічного Університету «Харківський політехнічний інститут», м. Харків; тел.: +38 (057) 707-66-34; e-mail: [perm\\_a@i.ua](mailto:perm_a@i.ua), <https://orcid.org/0000-0002-9589-0194>

**Харченко Олександр Сергійович (Харченко Александр Сергеевич, Kharchenko Oleksandr Sergvyovich)** – аспірант кафедри "Технологія машинобудування та металорізальні верстати" Національного Технічного Університету «Харківський політехнічний інститут», м. Харків; тел.: +380994819448; e-mail: [alexandr743@gmail.com](mailto:alexandr743@gmail.com), <https://orcid.org/0000-0002-7415-6169>