

Y. E. HOROSHAYLO, I. N. YARMAK, S. A. EFIMENKO

THE DEVICE FOR MEASURING COLOUR

In this paper, the authors propose a device for measuring the color characteristics of light reflected or transmitted through an optical medium. The main element of this device is the measuring transducer, which assigns to each radiation three signals proportional to the color coordinates. Existing devices have many drawbacks, among which low speed, due to the use of inert elements, which makes it impossible to measure rapidly changing light fluxes. In this device, the authors tried to minimize these limitations by using photodiodes and a microcontroller with a built-in ADC and other devices. Also in this article, a mathematical model of the device is proposed. Attention is paid to psychophysiological perception of color. As a result, we found a device that has a number of advantages over its counterparts, which makes it possible to perform color measurement with higher accuracy.

Keywords: measurement, device, color, photodiodes, microcontroller, mathematical model, psychophysiology of sight.

Ю. Є. ХОРОШАЙЛО, І. М. ЯРМАК, С. А. ЄФИМЕНКО **ПРИЛАД ДЛЯ ВИМІРЮВАННЯ КОЛЬОРУ**

Пропонується пристрій для вимірювання кольорних характеристик, яке за допомогою вимірювального перетворювача кожному випромінюванню ставить у відповідність три сигнали, пропорційних кольорних координат. Існуючі пристрої мають дуже багато недоліків, серед яких мала швидкість, в наслідок використання інертних елементів, що робить неможливим вимірювання швидкозмінних світлових потоків. У цьому пристрої автори спробували мінімізувати недоліки. Також в даній статті пропонується математична модель пристрою і приділено увагу психофізіологічному сприйняттю кольору.

Ключові слова: вимірювання, пристрій, колір, фотодіоди, мікроконтролер, математична модель, психофізіологія зору.

Ю. Е. ХОРОШАЙЛО, И. Н. ЯРМАК, С. А. ЕФИМЕНКО **УСТРОЙСТВО ДЛЯ ИЗМЕРЕНИЯ ЦВЕТА**

Предлагается устройство для измерения цветовых характеристик, которое с помощью измерительного преобразователя каждому излучению ставит в соответствие три сигнала, пропорциональных цветовых координат. Существующие устройства имеют очень много недостатков, среди которых малое быстродействие, вследствие использования инертных элементов, что делает невозможным измерения быстроизменяющихся световых потоков. В данном устройстве авторы попытались минимизировать недостатки. Также в данной статье предлагается математическая модель устройства. Уделено внимание психофизиологическому восприятию цвета.

Ключевые слова: измерение, устройство, цвет, фотодиоды, микроконтроллер, математическая модель, психофизиология зрения.

Introduction. For man, vision is the leading sensory system. At the biological level, this is confirmed by the fact that about half of the cerebral cortex is involved in the processing of visual information. Most of all information from the outside world (70-90%) is perceived by a person through a visual analyzer system. The leading role of the visual system is determined not only by the fact that it is a distant analyzer giving information about the surrounding world without direct contact with its objects, but also by the fact that in the images of visual sensations and perception the leading signs of objective reality—shape, size, are reflected. No analyzer system gives such complete information about the surrounding world as visual. Violation of certain visual functions, for example, color perception, is irreplaceable with the help of other analyzer systems. To a certain extent, visual representations can replace representations obtained from other analyzer systems. But the ideas received with the help of one of them and even all taken together can not completely compensate visual representations. Thanks to the sight, a person can freely orient in the world around him, his eyesight helps him to react quickly to the dangers that arise for his life, it makes it possible to see objects that are removed from the eyes by billions of kilometers. [1].

However, the close relationship between the activity of the visual system and the activities of other analyzer systems allows a person to activate the idea of the properties of the object, which were perceived by the contact method. For example, visually perceiving an object at a distance, it is possible to stimulate an idea of

the properties of an object that were perceived by the taste, olfactory, tactile and other analyzers (so the view of lemon and sugar creates an idea of sour and sweet, the kind of a flower - its smell, snow and fire - about their temperature, etc.). The combined and interconnectedness of various analyzer systems, with the leading role of the visual, unites them into a single aggregate, formed in the process of individual development and providing a sensual reflection of the world. [2].

Vision has a dual nature: daytime vision is carried out by cones, and night vision by chopsticks. The rod apparatus has a high light sensitivity, but it is not capable of transmitting a sensation of chromaticity; cones provide a uniform and color vision, but compared to the rods are much less sensitive to weak light and fully function only in good light. Depending on the degree of illumination, we can distinguish three varieties of the functional ability of the eye.

1. Day (photopic) vision is performed by the cone apparatus of the eye with a large intensity of illumination. It is characterized by high visual acuity and a clear, adequate perception of color.

2. Twilight (mesopic) vision is carried out by the rod apparatus of the eye with a low degree of illumination (0.1-0.3 lux). It is characterized by low visual acuity and achromatic (non-color) perception of objects. The lack of color perception in low light is well reflected in the proverb "at night all the cats are gray." [2].

3. Night (scotopic) vision is also carried out with chopsticks at very low illumination and reduces only to sensation of light.

Thus, the dual nature of vision requires a differentiated approach to the evaluation of visual functions. It is necessary to distinguish between central and peripheral vision.

Central vision is characterized by the ability of a person to distinguish between the form, the small details and the color of the objects in question. For the recognition of objects of the external world, it is necessary to distinguish between their individual details. The smaller the details are distinguished by the eye, the higher is his visual acuity. Under visual acuity it is accepted to understand the ability of the human eye to perceive separately the points located at a minimum distance from each other. In connection with the unequal distribution of cones in the retina, its various areas are uneven in visual acuity: as the distance from the retina center decreases, the visual acuity decreases. Already at a distance of 10° from the center it is 0.2 and even more reduced towards the periphery. Normal visual acuity in most adults corresponds to 1.

Color perception is the ability to distinguish colors. All the variety in the nature of flowers is divided into two groups - achromatic and chromatic. Achromatic include white, gray and black colors. All achromatic colors characterize one quality - brightness or lightness, i.e. degree of proximity to white. [2].

To chromatic colors are all the tones and shades of the color spectrum. They are characterized by three qualities: 1) color tone (the color feature differs from other colors of the spectrum: blue, red, yellow, etc.); 2) the saturation determined by the fraction of the main tone and the impurities to it of gray, which determines the intensity of the color; 3) brightness or lightness of color, degree of its proximity to white (light and darker colors). Different combinations of these characteristics give a variety of shades of chromatic color. A person is able to perceive about 180 color tones, and taking into account differences in brightness and saturation - more than 13 thousand. [3].

Peripheral vision plays a big role in human life: it serves for orientation in space, has high sensitivity to moving objects, serves a person in conditions of low illumination. Peripheral vision provided by the peripheral parts of the retina is determined by the magnitude and configuration of the field of vision - the space that is perceived by the eye (or eyes) with a fixed gaze. For achromatic (non-colored) objects, the normal field of view (with simultaneous viewing by both eyes) covers 180 degrees horizontally, 110 degrees vertically. The field of view of each eye has certain boundaries: the outside of the eye has 90° , the bottom out 90° , the bottom 60° , the bottom 50° , the inside 60° , 55° to the top, 55° to the top and 70° to the top. In both eyes, the boundaries of the field of view are symmetrical. [2].

Light perception is the ability of the eye to sense the minimum brightness of the active light. This property of the visual analyzer, which underlies all other visual functions. It manifests itself in the form of absolute light sensitivity, characterized by the threshold of sensation of light, and in the form of a distinctive light sensitivity, which makes it possible to sense an uneven brightness of light. Absolute light sensitivity is variable. It depends on

the degree of illumination, the change of which causes adaptive changes in the light sensitivity. This process is called adaptation, which protects the eye from overexertion, while preserving its high photosensitivity.

Isolate light and dark adaptation. Light adaptation, especially with a sharp increase in illumination, is accompanied by a protective reaction - blinking eyes. Adaptation to a different brightness of light comes fairly quickly, in the period from 50-60 seconds to 3 minutes. Complete addiction to the dark, dark adaptation, on the contrary is achieved slowly, only after 45-50 minutes. The duration of the process of light and dark adaptation depends on the level of the previous illumination: the more sharp the difference in the levels of illumination, the longer the adaptation. [3].

Binocular vision is the ability to perceive spatial relationships. This is the special most important complex function of the visual analyzer, which is the basis for the perfect adaptation of the organism to the conditions of the external environment. Binocular vision is provided through the fusion of visual information from both eyes into a single image in the cells of the cortex that are associated with the visual paths coming from each eye. The mechanism of binocular vision is based on accommodation and convergence. Accommodation is the change in the refractive power of the lens of the eye, which adapts it to a clear vision of differently distant objects. Convergence is the reduction of visual axes in the transition of fixation from a distant object to a near one. They act in concert: a change in accommodation leads to a change in convergence and vice versa. This ensures binocular fixation of objects located at close distances from the eyes. The divergence is the opposite of convergence, which consists in the fact that the visual axes are diluted when the fixation of the gaze from the near objects to the distant ones occurs. [5].

Main part. In this paper, the authors propose a device for measuring the color characteristics of light reflected or transmitted through an optical medium.

The main element of this device is the measuring transducer, which assigns to each radiation three signals proportional to the color coordinates.

Existing devices for measuring color characteristics have a number of drawbacks - low speed, due to the use of inert elements, which will make it impossible to measure rapidly changing light fluxes; insufficient measurement accuracy of the light flux, which has weak power (weakly illuminated objects) due to the low sensitivity of photoresistors, the inability to separate in the space of the measuring transducer and device; the inability to directly control device due to the implementation of controls, etc.

In the developed device for measuring color characteristics of objects, the authors tried to minimize the above disadvantages by using photodiodes and a microcontroller with a built-in ADC, reference lighting LEDs and a color measurement method that consists in determining the intensity of the three components R, G, B of the input light flux converting the data into a digital signal for the subsequent recalculation of the color coordinate signal x and y for the color chart CIE_{xy}, which will unambiguously characterize the color of the object,

expanding functionality by adding an interface control unit display facilities, the possibility of storing information on a memory card and the possibility of using the device in offline mode without involving a PC.

The device works as follows: a digital color measuring device that contains three light filters, three photosensitive elements, a normalizing amplifier, a microcontroller, a light stream, passing through the light filters, hits the photosensitive elements that are connected to the inputs of the normalized amplifiers, according to the invention, photodiodes are used as photosensitive elements, it additionally introduced two normalizing amplifiers, whose inputs are connected to photodiodes, and outputs with analog inputs of the microcontroller, LEDs e the lighting lights that are connected to the outputs of the microcontroller, control buttons that are connected to the inputs of the microcontroller, a liquid crystal indicator that is connected to the outputs of the microcontroller and a memory card that is connected to the outputs of the microcontroller (picture 1).

UA 123485 U

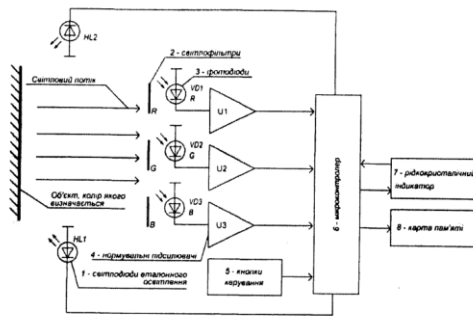

Pic 1 - Digital portable color measurement device

The authors suggest a mathematical model of a device for measuring color.

Formally we set the following problem. In the Hilbert space $L_2 [a, b]$ a system of functions $u_1(x), \dots, u_n(x)$ is given, it is required to define linear combinations with a set of coefficients $\{\alpha_{ji}\} (i=1,n)(j=1,n)$ for which the differences between given curves $h_j(x)$ and linear combinations

$$g_j(x) = \sum_{i=1}^n \alpha_{ji} U_i(x) \quad (1)$$

were minimal.

It is clear that with such a statement in the metric space $L_2 [a, b]$, the measure of the deviation is simply the metric of this space, that is

$$\Delta = \int_a^b (g_j(x) - h_j(x))^2 dx \quad (2)$$

To find the root-mean-square deviation, consider a linear combination $\sum_{i=1}^n \alpha_{ji} U_i(x)$ for which

$$\int_a^b (h_j(x) - \sum_{i=1}^n \alpha_{ji} U_i(x)) f_m(x) dx = 0 \quad (3)$$

$$m=1, \dots, n$$

The existence of a given linear combination follows from the fact that the coefficient α_{ji} is uniquely determined from the system of linear equations

$$\sum_{i=1}^n \alpha_{ji} \int_a^b U_i(x) \cdot U_m(x) dx = \int_a^b h_j(x) U_m(x) dx \quad (4)$$

It is not difficult to see that the matrix of this system is a Gram matrix for a set of functions $u_1(x), \dots, u_n(x)$ that are linearly independent, hence its determinant is not equal to zero. It is easy to show that expression (2) reaches its minimum on this linear combination. Indeed, for some other linear combination $\sum_{i=1}^n \alpha'_{ji} U_i(x)$ we consider expression (2) with allowance for (3). Then we get

$$\begin{aligned} & \int_a^b (h_j(x) - \sum_{i=1}^n \alpha'_{ji} U_i(x))^2 dx = \\ & = \int_a^b (h_j(x) - \sum_{i=1}^n \alpha_{ji} U_i(x) + \sum_{i=1}^n (\alpha_{ji} - \alpha'_{ji}) U_i(x))^2 dx = \\ & = \int_a^b (h_j(x) - \sum_{i=1}^n \alpha_{ji} U_i(x))^2 dx + \\ & + \int_a^b (\sum_{i=1}^n (\alpha_{ji} - \alpha'_{ji}) U_i(x))^2 dx \geq \\ & \geq \int_a^b (h_j(x) - \sum_{i=1}^n \alpha_{ji} U_i(x))^2 dx \end{aligned} \quad (5)$$

which indicates the validity of our statement.

We take an approximation of the integrals of system (4) on an arbitrary set of points $(x_1, \dots, x_q) \in [a, b]$.

Then

$$\int_a^b U_i(x) \cdot U_m(x) dx = \sum_{k=1}^q U_i(x_k) \cdot U_m(x_k) \quad (6)$$

We denote by

$$\sum_{k=1}^q U_i(x_k) \cdot U_m(x_k) = (U_i, U_m) \quad (7)$$

Then system (4) will have the form

$$\begin{aligned} \alpha_{j1}(U_1, U_1) + \dots + \alpha_{jn}(U_n, U_1) &= (h_j, U_1) \\ \dots & \dots \\ \alpha_{j1}(U_1, U_n) + \dots + \alpha_{jn}(U_n, U_n) &= (h_j, U_n) \end{aligned} \quad (8)$$

In this case, the minimum value Δ in expression (2) will be determined

$$\Delta = \sum_{k=1}^q (\sum_{i=1}^n \alpha_{ji} U_i(x_k) - h_j(x_k))^2 \quad (9)$$

Taking into account the fact that α_{ji} is solution of the system (8), then we finally obtain

$$\lambda = \frac{\begin{pmatrix} (U_1, U_1) & \dots & (U_n, U_1) & (h_j, U_1) \\ \dots & \dots & \dots & \dots \\ (U_1, U_n) & \dots & (U_n, U_n) & (h_j, U_n) \\ (h_j, U_1) & \dots & (h_j, U_n) & (h_j, h_j) \end{pmatrix}}{\begin{pmatrix} (U_1, U_1) & \dots & (U_n, U_1) \\ \dots & \dots & \dots \\ (U_1, U_n) & \dots & (U_n, U_n) \end{pmatrix}} \quad (10)$$

Conclusions. Finally, we received results which confirm that the device developed by the authors has a number of advantages over their analogues, which allows to carry out color measurement with higher accuracy.

References

1. Богданович Л. Б., Бурьян В. А., Раутман Ф. И., *Художественное конструирование в машиностроении*. Киев: Техніка, 1976. 183 с.
2. Варламов Р. Г., Струков О. Д., *Элементы художественного конструирования и технической эстетики*. Москва: Советское радио, 1980. 96 с.
3. Лютов В. П., Четверкин П. А., Головастики Г. Ю., *Цветоведение и основы колориметрии: учебник и практикум для академического бакалавриата*. Москва: Юрайт, 2018. 222 с.
4. Браэм Г. *Психология цвета*. Москва: АСТ, Астрель, 2009. 158 с.
5. Мураховский В. И., Симонович С. В., *Большая книга цифровой фотографии*, Пенза: Питер, 2012. 304 с.
6. Чуркин А. В., Уварова Р. М., Шашлов А. Б., *Основы светотехники. Учебник*. Москва: МГУП, 2002. 310 с.
7. Шашлов Б. А. *Цвет и цветовоспроизведение*. Москва: МГАП, Мир книги 1995. 245 с.
8. Гуревич М. М., *Фотометрия (теория, методы, приборы)*. Ленинград: Энергоатомиздат 1983. 415 с.
9. Джад Д., Вышецки Г., *Цвет в науке и технике*. - Киев: Мир, 1978. 112 с.
10. Кривошеев М. И., Кустарев А. К., *Цветовые измерения*. Минск: Энергоатомиздат, 1990. 215 с.
11. Пешкова В. М., Громова М. И., *Практическое руководство по спектрометрии и колориметрии*. Москва: МГУ, 1965. 272 с.

References (transliterated)

1. Bogdanovich L. B., Burian V.A., Rautman F.I. *Hudozhestvennoe konstruirovaniye v mashinostroenii* [Artistic design in mechanical engineering]. Kiev, Tehnika Publ., 1976. 183 p.
2. Varlamov R. G., Strukov O. D. *Elementy hudozhestvennogo konstruirovaniya i tehniceskoy estetiki* [Elements of artistic design and technical aesthetics]. Moscow, Soviet Radio Publ., 1980. 96 p.
3. Lyutov V. P., Chetverkin P. A., Golovastikov G. Yu. *Tsvetovedenie i osnovyi kolorimetrii: uchebnik i praktikum dlya akademicheskogo bakalavriata* [Color science and bases of colorimetry: a textbook and a practical work for academic baccalaureate]. Moscow, Yurayt Publ., 2018. 222 p.
4. Braham G. *Psihologiya tsveta* [Psychology of color]. Moscow, AST, Astrel, 2009. 158 p.
5. Murakhovskiy V. I., Simonovich S. V. *Bolshaya kniga tsifrovoy fotografii* [The Big Book of Digital Photography]. Penza, Peter Publ., 2012. 304 p.
6. Churkin A. V., Uvarova R. M., Shashlov A. B. *Osnovy svetotekhniki. Uchebnik* [Fundamentals of lighting technology]. Moscow, MGUP Publ., 2002. 310 p.
7. Shashlov B. A. *Tsvet i tsvetovosproizvedenie* [Color and color reproductions]. Moscow, MGAP, The World of the Book Publ., 1995. 245 p.
8. Gurevich M. M. *Fotometriya (teoriya, metody, pribory)* [Photometry (theory, methods, devices)]. Leningrad, Energoatomizdat 1983. 415 p.
9. Jad D., Vyshetsky G. *Tsvet v nauke i tehnikе* [Color in Science and Technology]. Kiev, Mir Publ., 1978. 112 p.
10. Krivosheev M. I., Kustarev A. K. *Tsvetovyye izmereniya* [Color measurements]. Minsk, Energoatomizdat Publ., 1990. 215 p.
11. Peshkova V. M., Gromova M. I. *Prakticheskoe rukovodstvo po spektrometrii i kolorimetrii* [Practical guide on spectrometry and colorimetry]. Moscow, Moscow State University Publ., 1965. 272 p.

Відомості про авторів / Сведения об авторах / About the Authors

Хорошайло Юрій Євгенійович (Хорошайло Юрий Евгениевич, Horoshaylo Yuriy Evgeniyovich) – кандидат технічних наук, професор, Харківський Національний університет радіоелектроніки, м. Харків, Україна;

Ярмак Іван Миколайович (Ярмак Иван Николаевич, Yarmak Ivan Mykolayovich) – Харківський національний університет радіоелектроніки, студент, м. Харків, Україна;

Єфименко Сергій Андрійович (Ефименко Сергей Андреевич, Efimenko Sergiy Andriyovich) – Харківський національний університет радіоелектроніки, аспірант, м. Харків, Україна;