

V. SAMORODOV, G. AVRUNIN

**SOLUTION OF THE PROBLEM OF CALCULATING THE LEAKAGE WORKING FLUID IN ECCENTRIC GAP OF THE BALL PISTON PAIR HYDRAULIC FLUID POWER MACHINE**

Goal. Conclusion of an analytical expression for calculating leaks in the gap between the ball-pistons and cylindrical holes in the cylinder blocks of radial-piston hydraulic pumps and hydraulic motors of hydraulic fluid power transmission. The object of study was the hydraulic fluid power transmission of the GOP-900 model in a monoblock design, consisting of a pump with an adjustable displacement and an hydraulic motor with a constant displacement. Method. For the laminar flow of the working fluid in the gap between the ball-piston and the cylinder, a calculation scheme is developed and a corresponding mathematical model is proposed for calculating the flow differential in each of the sections along the forming hole in the cylinder block of the hydraulic machine, followed by the integration of the specified differential. The calculation of the working fluid leaks in the MathCAD-15 medium allowed us to determine the average values of leaks with a concentric and eccentric arrangement of the piston balls in the holes of the cylinder blocks for specific set values for the diameters of the piston balls, the viscosity of the working fluid and the pressure drop between the discharge and discharge cavities. Results. For the first time analytical expressions are obtained that allow calculating leaks in the gap between the ball-piston and the hole in the cylinder block of a radial-piston hydraulic machine. The adequacy of the mathematical model is confirmed by the results of comparisons with the data of experimental measurements of working fluid leaks. It is shown that the coefficient of eccentricity of the circular gap used in the calculations using the Hagen-Poiseuille formula with a value of 2,5 is significantly overestimated. Conclusion. The method of calculating working fluid leaks in ball-piston hydraulic machines is recommended for use by specialists when developing new hydraulic machines and conducting diagnostics of the technical condition of those in operation in order to determine the volumetric efficiency and, in particular, its effect on the speed of vehicles whose transmissions use hydraulic machines with ball-pistons.

**Keywords:** fluid power hydraulic machines, hydraulic transmissions, ball-piston, cylinder, mathematical model, working fluid leaks, Reynolds number.

В. Б. САМОРОДОВ, Г. А. АВРУНИН

**РІШЕННЯ ЗАДАЧІ РОЗРАХУНКУ ВИТОКІВ РОБОЧОЇ РІДИНИ В ЕКСЦЕНТРИЧНОМУ ЗАЗОРІ ШАРИКОПОРШНЕВОЇ ПАРИ ОБ'ЄМНОЇ ГІДРОМАШИНИ**

Мета. Висновок аналітичного виразу для розрахунку витоків в зазорі між шариками-поршнями і циліндричними отворами в блоках циліндрів радіальнопоршневих гідромашин – насосів і гідромоторів об'ємних гідропередач. Об'єктом вивчення стала об'ємна гідропередача моделі ГОП-900 в моноблочному виконанні, що складається з насоса з регульованим робочим об'ємом і гідромотора з постійним робочим об'ємом. Метод. Для ламінарної течії робочої рідини в зазорі між шариком-поршнем і циліндром розроблена розрахункова схема і запропонована відповідна математична модель для обчислення диференціала витрати в кожному з перетинів уздовж отвору в блоці циліндрів гідромашини з подальшим інтегруванням вказаного диференціала. Розрахунок витоків робочої рідини в середовищі MathCAD-15 дозволив визначити середні значення витоків при концентричному і ексцентричному розташуванні шариків-поршнів в отворах блоків циліндрів для конкретних заданих значень по діаметрам шариків-поршнів, в'язкості робочої рідини і перепаду тиску між нагнітальною і зливною порожнинами. Результати. Вперше отримані аналітичні вирази, що дозволяють провести розрахунок витоків в зазорі між шариком-поршнем і отвором в блоці циліндрів радіальнопоршневої гідромашини. Підтверджено адекватність математичної моделі за результатами порівнянь з даними експериментальних вимірювань витоків робочої рідини. Показано, що використовуваний при розрахунках за формулою Гагена-Пуазейля коефіцієнт ексцентричності кругової щілини значенням в 2,5 є істотно завищеним. Укладення. Методика розрахунку витоків робочої рідини в шарикопоршневих гідромашинах рекомендується до використання фахівцями при розробці нових гідромашин і проведенні діагностики технічного стану тих, що знаходяться в експлуатації, з метою визначення об'ємного ККД і зокрема його впливу на швидкість транспортних засобів, в трансмісіях яких використовуються гідромашини з шариками-поршнями.

**Ключові слова:** об'ємні гідромашини, гідропередачі, шарик-поршень, циліндр, математична модель, витки робочої рідини, число Рейнольдса.

В. Б. САМОРОДОВ, Г. А. АВРУНИН

**РЕШЕНИЕ ЗАДАЧИ РАСЧЕТА УТЕЧЕК РАБОЧЕЙ ЖИДКОСТИ В ШАРИКОПОРШНЕВОЙ ПАРЕ ОБЪЕМНОЙ ГИДРОМАШИНЫ**

Цель. Вывод аналитического выражения для расчета утечек в зазоре между шариками-поршнями и цилиндрическими отверстиями в блоках цилиндров радиальнопоршневых гидромашин – насосов и гидромоторов объемных гидropередач. Объектом изучения явилась объемная гидropередача модели ГОП-900 в моноблочном исполнении, состоящая из насоса с регулируемым рабочим объемом и гидромотора с постоянным рабочим объемом. Метод. Для ламинарного течения рабочей жидкости в зазоре между шариком-поршнем и цилиндром разработана расчетная схема и предложена соответствующая математической модели для вычисления дифференциала расхода в каждом из сечений вдоль образующей отверстия в блоке цилиндров гидромашини с последующим интегрированием указанного дифференциала. Расчет утечек рабочей жидкости в среде MathCAD-15 позволил определить средние значения утечек при концентричном и эксцентричном расположении шариков-поршней в отверстиях блоков цилиндров для конкретных заданных значений по диаметрам шариков-поршней, вязкости рабочей жидкости и перепаду давления между нагнетательной и сливной полостями. Результаты. Впервые получены аналитические выражения, позволяющие произвести расчет утечек в зазоре между шариком-поршнем и отверстием в блоке цилиндров радиальнопоршневої гидромашини. Подтверждена адекватность математической модели по результатам сравнений с данными экспериментальных измерений утечек рабочей жидкости. Показано, что используемый при расчетах по формуле Гагена-Пуазейля коэффициент эксцентричности круговой щели значением в 2,5 является существенно завышенным. Заключение. Методика расчета утечек рабочей жидкости в шарикопоршневых гидромашинах рекомендуется к использованию специалистами при разработке новых гидромашин и проведении диагностики технического состояния находящихся в эксплуатации с целью определения объемного КПД и в частности его влияния на скорость транспортных средств, в трансмиссиях которых используются гидромашини с шариками-поршнями.

**Ключевые слова:** объемные гидромашини, гидropередачі, поршень-шарик, цилиндр, математическая модель, утечки рабочей жидкости, число Рейнольдса.

**Introduction.** Hydraulic fluid power [1] (HFP) have become widely used as straight-line and rotary transmissions in mobile machines for various purposes. When assessing the energy efficiency of the use of HFP, the efficiency is subject to evaluation, which significantly affects the fuel consumption as a parameter of the efficiency of the machine and the overall mass indicators, which mainly affect the cost of its manufacture. In hydraulic fluid power machines (pumps and hydraulic motors), the total efficiency and its components are distinguished – volumetric and hydromechanical efficiency. The volumetric efficiency takes into account the power losses due to the leakage of the working fluid (WF) through the gaps of the precision pairs, and the hydromechanical efficiency takes into account the losses on mechanical friction and in local resistances during the WF flow.

The object of the study is radial-piston pumps and hydraulic motors, in which the working chambers consist of ball-pistons in the cylindrical holes of the cylinder block. These hydraulic machines with ball-pistons have been used in mobile machines for general industrial and special purposes in the last thirty years due to advances in the technology of processing solid materials with high accuracy [2, 3]. Such hydraulic transmissions include monoblock HFP manufactured by Eaton [4] for agricultural and road construction vehicles, Bradley infantry fighting vehicle [5], HFP GOP-900 developed by NIIGidroprivod [2], in which radial-piston HFP are used in parallel power flow of two-stream hydraulic hydraulic fluid power-mechanical transmissions (GOMT), providing stepless speed control of rectilinear movement and rotation for mobile vehicles. Recently, information has appeared about the creation of hydraulic motors with ball pistons of the 1QJM series by the Chinese specialists of the company Ningo Kingbonny Machinery [6]. Hydraulic motors are multi-pass, i.e. with a profile cam for driving pistons, have a working volume from 83 cm<sup>3</sup> to 10150 cm<sup>3</sup>, a nominal pressure of 10–20 MPa (maximum 16–32 MPa), a speed of up to 800 min<sup>-1</sup>, develop a torque of up to 15 kNm and a power of up to 150 kW.

It should be noted that two-flow continuously variable automatic transmissions GOMT using HFP with ball-pistons belong to the advanced and effective direction of modernization of transmissions of mobile machines. The development of the domestic industry of hydraulic transmissions with ball-pistons of the GOP-900 type [7] and stepless two-flow HVMT for various purposes [8] became the basis for writing this article. For a number of years, the authors have provided a theoretical and experimental justification for the hydraulic transmission of the GOP-900.

**Analytical review of the literature.** The creation of the first domestic hydraulic transmission GOP-900 has become a powerful basis for analysis of the kinematics of ball piston jet ring stator, static and dynamic stress and strain, and of course, the analysis of power losses in friction hydraulic machines [9–16]. Such units are piston pairs and a trunnion-type distribution unit. At the same time, volume losses are caused by under-filling of the working chambers in the pump, internal and external leaks

through narrow working gaps, compressibility of the WF, which generally reduces the volumetric efficiency of the hydraulic machine, the HFP and the transmission in general. The hydrodynamic losses depend on the speed of the WF movement, the viscosity, and the geometry of the roughness class of the pipeline processing.

The solution to the fundamental problem of calculating the WF leaks between the ball-piston and cylinder hydraulic fluid power and hydraulic transmission is of particular importance and relevance to subsequent evaluation of the volumetric efficiency of the speed of the HFP with beads-pistons running in full flow transmissions and dual continuously variable GOMT. The analysis of numerous literature sources, including fundamental works of scientists and specialists in hydraulics and hydroaerodynamics, has shown that there is no solution to the problem of determining the flow rate of a liquid in a narrow concentric or eccentric gap between a ball and a cylinder under the influence of a pressure drop.

Experimental studies were limited to measuring the flow rate of leaks during static modeling of the ball in the cylinder or determining the total leaks in the piston pairs and the distribution unit [14]. The problem of analytical determination of leaks in the gap between the piston-ball and the cylinder is caused by the fact that in the well-known Hagen-Poiseuille formula [15] for the laminar flow regime of the WF, leaks are inversely proportional to the length of the sealing gap and in the case of the ball, the problem becomes formally indeterminate, since when the gap length tends to zero, the leak tends to infinity.

Due to the fact that the volume of WF leaks depends on the nature of its expiration, the problem of analytical calculation of leaks between the ball and the cylinder is solved in two stages – determining the mode of WF leakage (laminar or turbulent) in the gap and then creating a method for analytical calculation of the volume of WF leaks.

**The main part.** Fig. 1 shows a radial piston hydraulic transmission with ball-pistons GOP-900 of the NIIGidroprivod design [4]. Max capacity (displacement) of each hydraulic 680 cm<sup>3</sup>, the maximum frequency of rotation of a hydraulic motor up to 3100 min<sup>-1</sup>, pressure up to 32 MPa, output power up to 700 kW; temperature of up to 130 °C WF.

Let us solve the problem under the assumption that the Reynolds number Re is less than the critical one and the leakage between the ball and the piston is laminar. Number Re for annular slit:

$$\text{Re} = \frac{V_{av} \cdot d_h}{\nu} = \frac{V_{av} 2h}{\nu} = \frac{Q \cdot 2h}{2\pi R h \cdot \nu} = \frac{Q}{\pi R \cdot \nu}, \quad (1)$$

where

$V_{av}$  – is the average fluid velocity in the radial clearance  $h$ ;

$Q$  – fluid flow through the gap;

$R$  – the average radius of the annular slot (half-difference between the diameters of the cylinder and the ball-piston);

$\nu$  – the kinematic coefficient of viscosity of the fluid;

$d_h = 2h$  – hydraulic diameter.

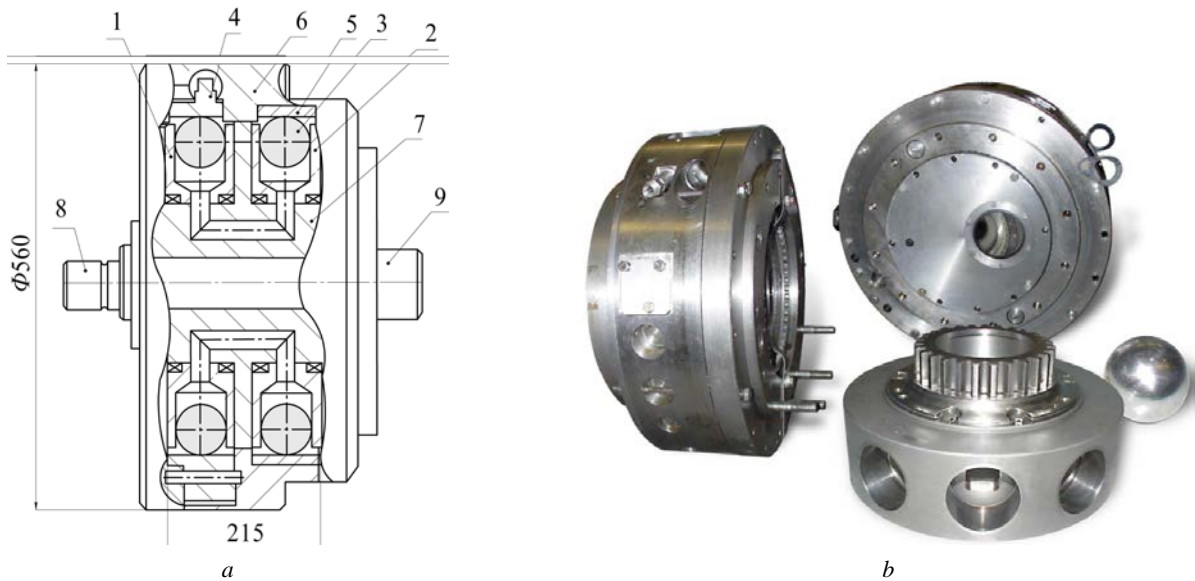

Fig. 1. Hydraulic transmission GOP-900 (a) and its individual parts (b):

1 and 2 – cylinder blocks of the pump and hydraulic motor, respectively; 3 – ball-piston; 4 and 5 – jet rings (clips) pump and hydraulic motor, respectively; 6 – housing; 7 – block of camshafts; 8 and 9 – input and output shafts

When determining the flow rate in an eccentric thin gap between the piston ball and the rotor (cylinder block) cylinder of a hydraulic machine, assuming the existence of a laminar flow (this will be justified below), it is assumed that the WF outflow is adiabatic. In the first approximation, the influence of the temperature gradient caused by the throttling effect on the change in the viscosity of the WF is not taken into account. The gap is considered to be eccentric with an eccentricity parameter  $\varepsilon = 1$  because the piston ball is constantly pressed against the cylinder wall in the contact reaction zone. In Fig. 2 shows a design diagram for determining the differential of the flow rate  $dQ$  in the diametrical section of the ball-piston along the generatrix of the rotor cylinder.

An elementary slot with a width  $dx$  with a variable gap  $h$  and a total pressure drop is considered  $\Delta p = p_1 - p_a$  (where  $p_a$  – is the atmospheric outlet pressure), divided into  $n$  sections. Each selected section is a rectangle with vertices  $A_i$  and  $B_i$ ; a constant flow rate flows  $dQ$ . The angle  $\varphi$  is chosen small (0,05–0,30 rad), but arbitrary and, as will be shown below, its value affects the calculation of the elementary flow rate  $dQ$ . The flow rate between sections 1 and 2 has the form of recording:

$$dQ = \frac{(p_1 - p_2)(0,5(h_1 + h_2) + \delta)^3 dx}{12\mu R \frac{\varphi}{n} \cos \varphi}, \quad (2)$$

where

$p_1$  and  $p_2$  – are the pressures in the sections;

$\delta$  – the smallest clearance between the ball and the cylinder;

$0,5(h_1 + h_2) + \delta$  – is the average gap in an elementary

slot on the path  $B_1B_2 = R \frac{\varphi}{n} \cos \varphi$ .

The clearance  $\delta$  is constant when the ball-piston is concentric in the cylinder and is equal to zero when

pressed against its wall. Below in Fig. 3 at the point of contact is shown the contact reaction  $N$  acting on the ball-piston during the operation of the hydraulic machine.

Variable parameters characterizing the change in the gap in sections 1 and 2 are given by formulas

$$h_1 = 2R \sin^2 \frac{\varphi}{2}; \quad h_2 = 2R \cdot \sin^2 \left( \frac{n-1}{n} \cdot \frac{\varphi}{2} \right).$$

Let us construct a chain of equalities for  $n$  sections of an elementary gap.

$$dQ = \frac{p_1 - p_2}{12\mu R} \cdot \frac{\left[ R \sin^2 \frac{\varphi}{2} + R \sin^2 \left( \frac{n-1}{n} \cdot \frac{\varphi}{2} \right) + \delta \right]^3}{\frac{\varphi}{n} \cos \varphi};$$

$$dQ = \frac{p_2 - p_3}{12\mu R} \times$$

$$\times \frac{\left[ R \sin^2 \left( \frac{n-1}{n} \cdot \frac{\varphi}{2} \right) + R \sin^2 \left( \frac{n-2}{n} \cdot \frac{\varphi}{2} \right) + \delta \right]^3}{\frac{\varphi}{n} \cos \left( \frac{n-1}{n} \varphi \right)}; \quad (3)$$

$$dQ = \frac{p_i - p_{i+1}}{12\mu R} \times$$

$$\times \frac{\left[ R \sin^2 \left( \frac{n-i+1}{n} \cdot \frac{\varphi}{2} \right) + R \sin^2 \left( \frac{n-i}{n} \cdot \frac{\varphi}{2} \right) + \delta \right]^3}{\frac{\varphi}{n} \cos \left( \frac{n-i+1}{n} \varphi \right)},$$

where  $i$  – is the number of sections, which varies from 1 to  $n_\varphi$ .

In this case, at the exit from the slot  $p_{n+1} = p_a$ .

Sequentially equating the  $i$ -equation with the  $i-1$  equation, starting with the last one at  $i=n$ , excluding  $p_n, p_{n-1}, \dots, p_2$ , we obtain the general formula for calculating the leakage differential:

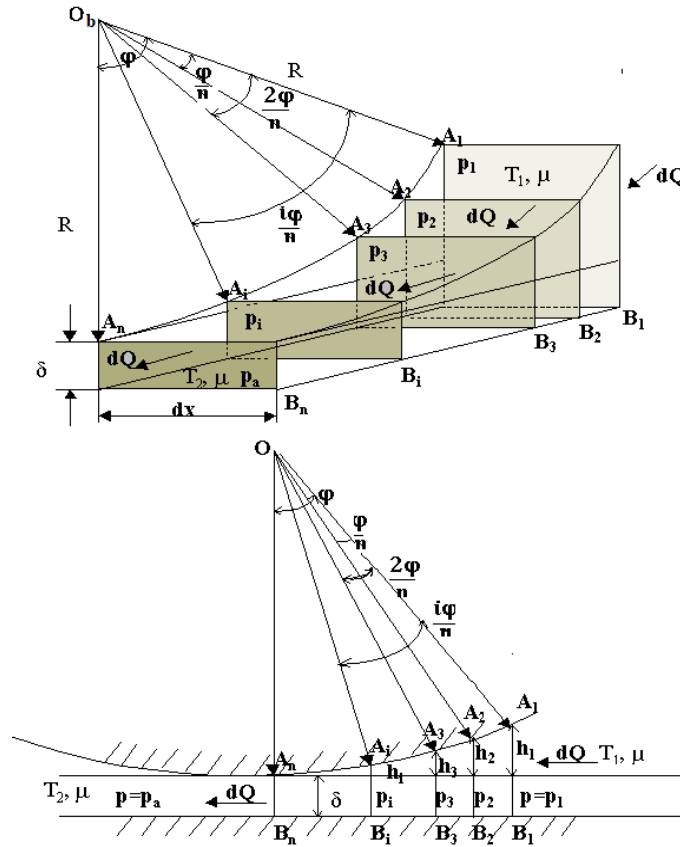

Fig. 2. Design scheme for determining the flow rate in the gap between the piston-ball and the cylinder

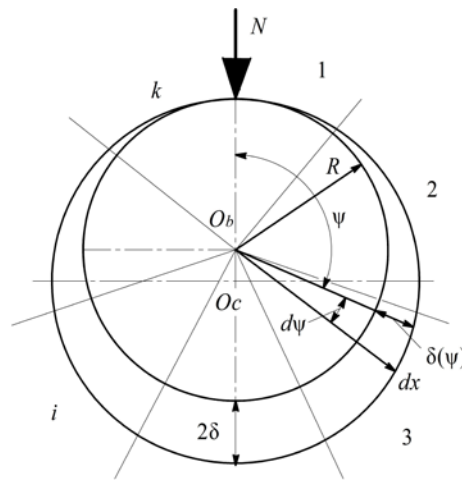

Fig. 3. To the calculation of the flow rate in the eccentric clearance between the piston ball and the cylinder

$$dQ = \frac{(p_1 - p_a)dx}{12\mu R} \times \frac{n}{\cos\left(\frac{n-i+1}{n} \cdot \varphi\right)} \times \frac{\varphi}{\sum_{i=1}^n \left[ R \sin^2\left(\frac{n-i+1}{n} \cdot \frac{\varphi}{2}\right) + R \sin^2\left(\frac{n-i}{n} \cdot \frac{\varphi}{2}\right) + \delta \right]^3} \quad (4)$$

A series of a kind:

$$S_n = \frac{n}{\cos\left(\frac{n-i+1}{n} \cdot \varphi\right)} \times \frac{\varphi}{\sum_{i=1}^n \left[ R \sin^2\left(\frac{n-i+1}{n} \cdot \frac{\varphi}{2}\right) + R \sin^2\left(\frac{n-i}{n} \cdot \frac{\varphi}{2}\right) + \delta \right]^3} \quad (5)$$

was investigated for convergence at  $n \rightarrow \infty$  in the MathCAD-15 based on the d'Alembert test, when the limit of the ratio of the next member of the series  $S_{n+1}$  to  $S_n$  with an unlimited increase in  $n$  remains less than 1 and the

series  $S_n$  converges.

Table 1 shows the results of the influence on the convergence of the  $S_n$  series (5) and on the flow rate  $Q_{conc}$  through the concentric slot of the number  $n$  of splits and the angle  $\varphi$ . In this case, the flow rate through a concentric slit with a radius of  $R = 0,03175$  m with a gap of  $\delta = 20 \mu\text{m}$  at a dynamic viscosity coefficient  $\mu = 0,0144$  Pa·s, a pressure  $p_1 = 10$  MPa and  $\varphi = 0,1$  rad tends to a value of  $139 \text{ cm}^3/\text{s}$ .

As you can see, with the number of partitions  $n = 10-1000$ , the flow rate  $Q_{conc}$ , expressed for convenience in  $\text{cm}^3/\text{s}$ , for different  $\varphi = 0,05-0,3$  has a stable tendency to convergence due to the convergence of the series (5).

Taking into account the eccentricity between the piston ball and the cylinder (Fig. 3)  $\delta(\psi) = \delta(1 - \varepsilon \cdot \cos\psi)$ , the differential  $dx = R d\psi$ ; eccentricity parameter  $\varepsilon = 1$ .

Then the expression for the numerical integration of the total fluid flow rate between the piston ball and the cylinder has the form:

$$\Delta\tilde{Q}_1 = \frac{(p_1 - p_a)}{12\mu R} \times \left[ \lim_{n \rightarrow \infty} \int_0^{2\pi} \frac{n \cos\left(\frac{n-i+1}{n} \cdot \varphi\right)}{\varphi \sum_{i=1}^n \left[ R \sin^2\left(\frac{n-i+1}{n} \cdot \frac{\varphi}{2}\right) + R \sin^2\left(\frac{n-i}{n} \cdot \frac{\varphi}{2}\right) + \delta(1 - \cos\psi) \right]^3} d\psi \right] \quad (6)$$

Formula (6) at  $\varepsilon = 0$  gives a special case for estimating the flow rate between the cylinder and the piston ball when they are concentric. If in the formula (6) we take at small  $\varphi$  the leakage path  $L$  equal to  $B_1 B_{n+1} = R\varphi$  and

$$\begin{aligned} \cos\left(\frac{n-i+1}{n} \cdot \varphi\right) &= 1; \quad \sin^2\left(\frac{n-i+1}{n} \cdot \frac{\varphi}{2}\right) = 0; \\ \sin^2\left(\frac{n-i}{n} \cdot \frac{\varphi}{2}\right) &= 0, \end{aligned}$$

Table 1 – Influence of parameters  $n$  and  $\varphi$  on the convergence of the series (5) and outflow  $Q_{conc}$

$n$	Outflow $Q_{conc}$ , $\text{cm}^3/\text{s}$					
	$\varphi = 0,05$	$\varphi = 0,1$	$\varphi = 0,15$	$\varphi = 0,2$	$\varphi = 0,25$	$\varphi = 0,3$
10	144,56	146,39	155,27	168,65	–	–
100	142,79	139,43	139,34	139,44	139,59	139,78
200	142,77	139,37	139,22	139,23	139,26	139,31
500	142,77	139,36	139,19	139,17	139,17	139,17
1000	142,77	139,36	138,18	139,16	139,16	139,16

Table 2 – Research of expenses according to the formula (7) for different  $k$  and  $R$

$R$ , sm	$Q_{ecc}$ , $\text{sm}^3/\text{s}$ to the formula (6)			$Q_{conc}$ , $\text{sm}^3/\text{s}$	$Q_{ecc}/Q_{conc}$
	$k = 10$	$k = 100$	$k = 360$	$k = 360$	$k = 360$
1	156,87	156,88	156,88	79,66	1,969
2	214,92	214,92	214,92	111,22	1,932
3,175	268,66	268,66	268,66	139,76	1,922
4	300,95	300,95	300,95	156,78	1,919

then the relation (6) takes the well-known expression for determining the differential of the flow rate in a narrow flat slot

$$\Delta\tilde{Q}_1 = dQ = \frac{(p_1 - p_0) dx}{12\mu L} \cdot \frac{n}{\sum_{i=1}^n \frac{1}{\delta^3}} = \frac{\Delta p \delta^3 dx}{12\mu L} \quad (7)$$

According to the formula (6), it is necessary to make three important remarks. First, in the presence of eccentricity  $\varepsilon \in (0;1]$  in the annular gap, the known factor  $1 + 1,5\varepsilon^2$  cannot be used to change from the flow rate through the concentric annular slot to the flow rate in the eccentric slot. At  $\varepsilon = 1$  the flow rate in the eccentric slot increases by 2,5 times in comparison with the concentric slot. In the case of an outflow between the ball and the cylinder, the studies carried out in the MathCAD environment give another important factor for practice, equal to about 1,93, i. e. less than 2,5. The results of this study of costs are shown in Table 2 with numerical integration according to the formula (6) for the number of partitions of the gap  $k = 10$ ;  $k = 100$  and  $k = 360$  of the integration interval  $[0; 2\pi]$ .

For  $n = 200$ ,  $\varphi = 0,1$ , the convergence of the flow rate on  $k$  can be considered ideal for practice. The flow rate ratio at  $\varepsilon = 1$  and  $\varepsilon = 0$  in accordance with the research results given in Table 2 (for different ball radius  $R$  at a pressure drop  $\Delta p = 10$  MPa,  $\mu = 0,0144$  Pa·s,  $\delta = 20 \mu\text{m}$ ,  $n = 200$ ,  $\varphi = 0,1$  rad) gives an approximately constant ratio 1,92–1,96.

Secondly, it is necessary to pay special attention to the reliability of the assumption that the outflow through a narrow gap between the ball and the cylinder is of a laminar nature and the entire theory presented, which is based on the Hagen-Poiseuille formula [15], is applicable. Let, for definiteness, the annular eccentric gap be divided into  $k = 16$  equal parts ( $2\pi/16$ ) and in each elementary section (Fig. 4) the number (Table 3) is estimated for different radial gaps ( $10 \mu\text{m}$ ,  $12,5 \mu\text{m}$ ,  $15 \mu\text{m}$  and  $18$  microns).

Table 3 – Values of the number in the eccentric clearance between the ball-piston and the cylinder

k	Radial clearance between ball and cylinder $\delta$ , $\mu\text{m}$							
	$\Delta p = 10 \text{ MPa}$				$\Delta p = 25 \text{ MPa}$			
	10	12,5	15	18	10	12,5	15	18
	Re				Re			
1	0,0	0,0	0,1	0,1	0,0	0,1	0,2	0,3
2	0,7	1,3	2,0	3,2	1,8	3,2	5,0	8,0
3	4,7	8,2	13,0	20,5	11,8	20,6	32,5	51,3
4	15,7	27,5	43,5	68,5	39,4	68,9	108,6	171,4
5	35,4	61,9	97,8	154,4	88,6	154,9	244,4	385,9
6	60,1	105,0	165,8	261,8	150,2	262,5	414,4	654,6
7	81,0	141,6	223,7	353,4	202,5	354,1	559,2	883,5
8	89,3	156,1	246,5	389,6	223,2	390,3	616,4	974,0
9	81,0	141,6	223,7	353,4	202,5	354,4	559,2	883,5
10	60,1	105,0	165,8	261,8	150,2	262,5	414,4	654,6
11	35,4	61,9	97,8	154,4	88,6	154,9	244,4	385,9
12	15,7	27,5	43,5	68,5	39,4	68,9	108,6	171,4
13	4,7	8,2	13,0	20,5	11,8	20,6	32,5	51,3
14	0,7	1,3	2,0	3,2	1,8	3,2	5,0	8,0
15	0,0	0,0	0,1	0,1	0,0	0,1	0,2	0,3
16	0	0	0	0	0	0	0	0
$V_{av}$	29	50	80	127	74	127	204	323
$\Delta Q_1$ , $\text{sm}^3/\text{s}$	<b>47,3</b>	<b>82,7</b>	<b>130,6</b>	<b>206,2</b>	<b>118,3</b>	<b>206,6</b>	<b>326,4</b>	<b>515,6</b>

As you can see from the Table 3, for 10 MPa the maximum number Re does not exceed 400 (average – no more than 127). For a control point pressure of 25 MPa, the maximum number Re (Table 3) does not exceed 1000 (the average is not more than 330), i. e. much lower than critical.

Experimental pouring of a ball in a cylinder with TAD-17(GL-5) oil at a temperature  $T = 100 \text{ }^\circ\text{C}$  and a radial clearance  $\delta = 15 \text{ }\mu\text{m}$  under a pressure of 10 MPa, carried out in the laboratory of the NIIGidroprivod – Research Institute of Hydraulic Drive (Ukraine, Kharkov), fully confirmed the laminar nature of the RL flow. Unfortunately, such a test was not carried out for a load pressure of 25–30 MPa.

However, in the laboratory of NIIGidroprivod, a mock-up of a piston-ball in a cylinder was tested during spillage in a static mode of supplying WF under a pressure of up to 20 MPa with the following data:  $\Delta p = 5\text{--}20 \text{ MPa}$ ,  $\mu = 0,018 \text{ Pa}\cdot\text{s}$  ( $\nu = 20 \text{ mm}^2/\text{s}$  at  $\rho = 900 \text{ kg}/\text{m}^3$ ),  $\delta = 9\text{--}12 \text{ }\mu\text{m}$ ,  $D = 2R = 50,8 \text{ mm}$ . The experimental leakage value was 2,73 l/min. The calculated value according to the algorithm developed above for the indicated data (specifically for  $\delta = 12 \text{ }\mu\text{m}$ ) for a piston ball with  $D = 50,8 \text{ mm}$  was 6,41 l/min.

The participants of the experiment, however, note a possible inaccuracy in the above initial data. So the kinematic coefficient of viscosity  $\nu$  during the experiment could be in the range  $\nu = 18\text{--}23 \text{ mm}^2/\text{s}$ . The gap between the piston-ball and the cylinder was determined by measurement as  $\delta = 12 \text{ }\mu\text{m}$  with a possible error 3–5  $\mu\text{m}$ . It turned out that at the values of these "suspicious" parameters  $\nu = 23 \text{ mm}^2/\text{s}$  and  $\delta = 9,2 \text{ }\mu\text{m}$  (these values are included in the range of errors), the calculation according to the proposed algorithm gives a leakage of 2,78 l/min (close to the experimental value of 2,73 l/min at  $\nu = 20 \text{ mm}^2/\text{s}$  and  $\delta = 12 \text{ }\mu\text{m}$ ). Further theoretical and experimental developments will make it possible to clarify analytical expressions and an algorithm for calculating leaks in thin eccentric slots between piston balls and guide cylinders in rotors of modern radial piston hydraulic machines.

**Conclusion.** 1. Shown and substantiated the existence of a laminar flow regime of the working fluid in the gap between the ball-piston and the cylinder in the rotors of powerful radial-piston modern hydraulic machines in the entire range of their operating parameters.

2. A mathematical model of the flow of the working fluid in the eccentric gap between the ball-piston and the cylinder of radial-piston hydraulic transmission machines of the GOP-900 type has been developed. The problem is solved on the basis of the principle of passing a constant differential of pressure leaks through a set of elementary planes with their elementary pressure drops and by way of leaks, i. e. finite elements for which the Hagen-Poiseuille formula is applied. The integral calculated values of leaks in the case of a laminar flow are obtained. The problem with determining unproductive fluid leaks between the piston ball and the cylinder is that the zero leakage path in the denominator of the Hagen-Poiseuille formula turns the leak into infinity. The proposed mathematical model solves this issue.

3. The ratio of working fluid leaks with an eccentric and concentric arrangement of the ball-piston in the cylinder is 1,93, which is almost 30 % less than that used in the Hagen-Poiseuille formula for calculating leaks in a spool or piston pair with a real value of the sealing gap.

4. The developed method of analytical calculation is recommended for use in design calculations of volumetric hydraulic transmissions of radial piston type with piston balls to assess pressure leaks and is decisive in determining their volumetric efficiency.

#### Список літератури

1. ДСТУ 3455.1-96. Гідроприводи об'ємні та пневмоприводи. Частина 1. Загальні поняття. Терміни та визначення (ISO 5598:1985, NEQ) / Нац. Стандарт України України. Київ: Держспоживстандарт України, 1998. 48 с.
2. Борисюк М. Д., Бусяк Ю. М., Аврунин Г. А., Большаков А. К., Кабаненко И. В., Хавиль В. В. Новое поколение шарикопоршневых гидротрансформаторов. Промислова гідроліка і пневматика. 2003. № 1. С. 66–70.
3. The Internet Glossary of Pumps. Created by: The Animated Software Company. Ball Piston Pump. URL: <https://www.animatedsoftware.com/pumpglos/ballpist.htm> (дата

- звернення: 24.04.2021).
- Eaton Light Duty Hydrostatic. Hydrostatic Transmissions – Models 6, 7 and 11. Ball Piston Pumps – Models 7 and 11. *EATON Powering Business Worldwide*. Document no. E-TRLD001-E1. Supersedes 11-04-880 EN-0900. 2016. 22 p.
  - URL: [https://web.archive.org/web/20140202214442/http://liveguns.ru/bmp/M2\\_Bradley](https://web.archive.org/web/20140202214442/http://liveguns.ru/bmp/M2_Bradley) (дата звернення: 17.04.2021).
  - URL: <https://wuxihyphen.en.made-in-china.com/product/EqrmStgbbXcF/China-Sphere-Piston-Hydraulic-Motor-1QJM01-.html> (дата звернення: 15.04.2021).
  - Аврунин Г. А., Кабаненко И. В., Хавил' В. В., Истратов А. В., Богачев С. В., Лизунов К. М. Объемная гидropередача с шариковыми поршнями ГОП-900: характеристики и технический уровень. *Механіка та машинобудування*. 2004. № 1. С. 14–21.
  - Самородов В. Б., Аврунин Г. А., Кириченко І. Г., Бондаренко А. І., Пелипенко Є. С. *Гідро- та пневмосистеми в автотракторобудуванні: навч. посіб.* / ред. Самородов В. Б. Харків: НТУ «ХПІ», ФОП Панов А. М., 2020. 524 с.
  - Лойцянский Л. Г. *Механика жидкости и газа*. Москва: Наука, 1970. 904 с.
  - Рогов А. В., Ярмач Н. С., Истратов А. В. Математическая модель гидромеханических и объемных потерь в перспективной гидрообъемной передаче ГОП-900. *Механіка та машинобудування*. 2004. № 2. С. 200–214.
  - Самородов В. Б. Напорные утечки рабочей жидкости между шаром-поршнем и цилиндром ротора в быстроходных радиально-поршневых гидромашинах – элементах гидрообъемно-механических трансмиссий. *Вестник ХГПУ. Сер.: НРСТ*. 2000. Вып. 79. С. 28–31.
  - Климов В. Ф., Ярмач Н. С., Истратов А. В. Техническое обеспечение исследований объемных гидромашин с шаровыми поршнями, расширение диагностических параметров и их информативности. *Механіка та машинобудування*. 2003. № 1. С. 201–208.
  - Ярмач Н. С. Исследование динамических процессов гидромашин объемного типа, диагностика и идентификация дефектов. *Механіка та машинобудування*. 2004. № 1. С. 35–45.
  - Аврунин Г. А., Истратов А. В., Кабаненко И. В. Определение утечек рабочей жидкости между поршнями и цилиндром радиальной шарикопоршневой гидромашин. *Промислова гідроліка і пневматика*. 2004. № 4 (6). С. 41–43.
  - URL: <https://studfile.net/preview/10032822/page:8/> (дата звернення: 15.04.2021).
  - Самородов В. Б., Рогов А. В., Ярмач Н. С. Математическое моделирование гидромеханических потерь и КПД в быстроходных гидрообъемных машинах с шаровыми поршнями. *Вісник Нац. техн. ун-ту «ХПІ»: зб. наук. пр. Темат. вип.: Динаміка і міцність машин*. Харків: НТУ «ХПІ». 2002. № 10, т. 2. С. 165–172.
  - 6, 7 and 11. Ball Piston Pumps – Models 7 and 11. *EATON Powering Business Worldwide*. Document no. E-TRLD001-E1. Supersedes 11-04-880 EN-0900. 2016. 22 p.
  - Available at: [https://web.archive.org/web/20140202214442/http://liveguns.ru/bmp/M2\\_Bradley](https://web.archive.org/web/20140202214442/http://liveguns.ru/bmp/M2_Bradley) (accessed 17.04.2021).
  - Available at: <https://wuxihyphen.en.made-in-china.com/product/EqrmStgbbXcF/China-Sphere-Piston-Hydraulic-Motor-1QJM01-.html> (accessed 15.04.2021).
  - Avrunin G. A., Kabanenko I. V., Khavil' V. V., Istratov A. V., Bogachev S. V., Lizunov K. M. Ob'emnaya gidropredacha s шариковыми porshnyami GOP-900: kharakteristiki i tekhnicheskiy uroven' [Volumetric hydraulic transmission with ball pistons GOP-900: characteristics and technical level]. *Mekhanika ta mashynobuduvannya*. 2004, no. 1, pp. 14–21.
  - Samorodov V. B., Avrunin H. A., Kyrychenko I. H., Bondarenko A. I., Pelypenko Ye. S. *Hidro- ta pnevmosystemy v avtotraktorobuduvanni: navch. posib.* [Hydraulic and pneumatic systems in tractor construction]. Kharkiv, NTU "KhPI" Publ., FOP Panov A. M. Publ., 2020. 524 p.
  - Loityanskiy L. G. *Mekhanika zhidkosti i gaza* [Mechanics of liquid and gas]. Moscow, Nauka Publ., 1970. 904 p.
  - Rogov A. V., Yarmak N. S., Istratov A. V. Matematicheskaya model' gidromekhanicheskikh i ob'emnykh poter' v perspektivnoy gidroob'emnoy peredache GOP-900 [Mathematical model of hydromechanical and volumetric losses in the perspective hydrostatic transmission GOP-900]. *Mekhanika ta mashynobuduvannya*. 2004, no. 2, pp. 200–214.
  - Samorodov V. B. Napornye utechki rabochey zhidkosti mezhdunarom-porshnem i tsilindrom ratora v bystrokhodnykh radial'no-porshnevyykh gidromashinakh – elementakh gidroob'emnomekhanicheskikh transmissiy [Pressure leaks of the working fluid between the piston ball and the rotor cylinder in high-speed radial piston hydraulic machines – elements of hydrostatic-mechanical transmissions]. *Vestnik HGPU. Seriya NRST* [Bulletin of Kharkiv State Polytechnic University. Series: New solutions in modern technologies]. 2000, issue 79, pp. 28–31.
  - Klimov V. F., Yarmak N. S., Istratov A. V. Tekhnicheskoe obespechenie issledovaniy ob'emnykh gidromashin s шаровыми поршнями, rasshirenie diagnosticheskikh parametrov i ikh informativnosti [Technical support of research of volumetric hydraulic machines with ball and pistons, expansion of diagnostic parameters and their information content]. *Mekhanika ta mashynobuduvannya*. 2003, no. 1, pp. 201–208.
  - Yarmak N. S. Issledovanie dinamicheskikh protsessov gidromashin ob'emnogo tipa, diagnostika i identifikatsiya defektov [Investigation of dynamic processes of positive displacement hydraulic machines, diagnostics and identification of defects]. *Mekhanika ta mashynobuduvannya*. 2004, no. 1, pp. 35–45.
  - Avrunin G. A., Istratov A. V., Kabanenko I. V. Opredelenie utechek rabochey zhidkosti mezhdunarom-porshnyami i tsilindrami radial'noy шарикопоршнеvoy gidromashiny [Determination of leaks of working fluid between pistons and cylinders of a radial ball piston hydraulic machine]. *Promyslova hidravlika i pnevmatika*. 2004, no. 4 (6), pp. 41–43.
  - Available at: <https://studfile.net/preview/10032822/page:8/> (accessed 15.04.2021).
  - Samorodov V. B., Rogov A. V., Yarmak N. S. Matematicheskoe modelirovanie gidromekhanicheskikh poter' i KPD v bystrokhodnykh gidroob'emnykh mashinakh s шаровыми поршнями [Mathematical modeling of hydromechanical losses and efficiency in high-speed hydrostatic machines with ball pistons]. *Vistnyk Nats. tekhn. un-tu "KhPI": zb. nauk. pr. Temat. vyp.: Dynamika i mitsnist' mashyn* [Bulletin of the National Technical University "KhPI": a collection of scientific papers. Thematic issue: Dynamics and strength of machines]. Kharkiv, NTU "KhPI" Publ., 2002, no. 10, vol. 2, pp. 165–172.

## References (transliterated)

- DSTU 3455.1-96. *Hidropryvody ob'yemni ta pnevmopryvody. Chastyna 1. Zahal'ni ponyattya. Terminy ta vyznachennya* [State Standard 3455.1-96. Volumetric hydraulic drives and pneumatic drives. Part 1. General. Terms and definitions]. Kyiv: Ukrainian Research and Training Center of Standardization, Certification and Quality Publ., 1998. 48 p.
- Borisyuk M. D., Busyak Yu. M., Avrunin G. A., Bol'shakov A. K., Kabanenko I. V., Khavil' V. V. Novee pokolenie шарикопоршневyykh gidropredach [New generation of ball-piston hydraulic transmission]. *Promyslova hidravlika i pnevmatika*. 2003, no. 1, pp. 66–70.
- The Internet Glossary of Pumps. Created by: The Animated Software Company. Ball Piston Pump*. Available at: <https://www.animatedsoftware.com/pumpglos/ballpist.htm> (accessed 24.04.2021).
- Eaton Light Duty Hydrostatic. Hydrostatic Transmissions – Models

Received 26.04.2021

## Відомості про авторів / Сведения об авторах / About the Authors

**Самородов Вадим Борисович (Самородов Вадим Борисович, Samorodov Vadym)** – доктор технічних наук, професор, Національний технічний університет «Харківський політехнічний інститут», завідувач кафедри «Автомобіле- та тракторобудування», м. Харків, Україна; ORCID: <https://orcid.org/0000-0002-2965-5460>; e-mail: samorodovvadimat@gmail.com

**Аврунін Григорій Аврамович (Аврунин Григорій Аврамович, Avrunin Grigory)** – кандидат технічних наук, доцент, Харківський національний автомобільно-дорожній університет, доцент кафедри «Будівельні і дорожні машини», м. Харків, Україна; ORCID: <https://orcid.org/0000-0002-0191-3149>; e-mail: griavrunin@ukr.net